

Trench gate field-stop IGBT, HB series 650 V, 30 A high speed

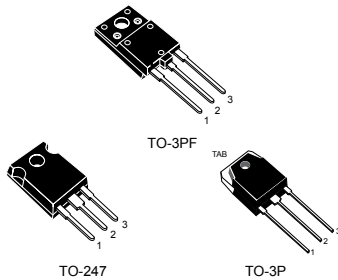

Features

- Maximum junction temperature: $T_J = 175\text{ }^\circ\text{C}$
- High speed switching series
- Minimized tail current
- $V_{CE(sat)} = 1.55\text{ V (typ.) @ } I_C = 30\text{ A}$
- Tight parameters distribution
- Safe paralleling
- Low thermal resistance

Applications

- Photovoltaic inverters
- Power factor correction
- Welding
- High-frequency converters

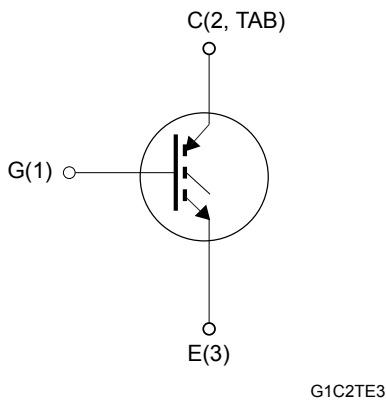

Description

These devices are IGBTs developed using an advanced proprietary trench gate field-stop structure. These devices are part of the new HB series of IGBTs, which represent an optimum compromise between conduction and switching loss to maximize the efficiency of any frequency converter. Furthermore, the slightly positive $V_{CE(sat)}$ temperature coefficient and very tight parameter distribution result in safer paralleling operation.



Product status links

[STGFW30H65FB](#)

[STGW30H65FB](#)

[STGWT30H65FB](#)

1 Electrical ratings

Table 1. Absolute maximum ratings

Symbol	Parameter	Value		Unit
		TO-247, TO-3P	TO-3PF	
V_{CES}	Collector-emitter voltage ($V_{GE} = 0$ V)	650		V
I_C	Continuous collector current at $T_C = 25$ °C	60		A
	Continuous collector current at $T_C = 100$ °C	30		A
$I_{CP}^{(1)}$	Pulsed collector current	120		A
V_{GE}	Gate-emitter voltage	±20		V
P_{TOT}	Total power dissipation at $T_C = 25$ °C	260	58	W
V_{ISO}	Insulation withstand voltage (RMS) from all three leads to external heat sink ($t = 1$ s; $T_C = 25$ °C)		3.5	kV
T_{stg}	Storage temperature range	-55 to 150		°C
T_J	Operating junction temperature range	-55 to 175		°C

1. Pulse width is limited by maximum junction temperature.

Table 2. Thermal data

Symbol	Parameter	Value		Unit
		TO-247, TO-3P	TO-3PF	
R_{thJC}	Thermal resistance junction-case	0.58	2.60	°C/W
R_{thJA}	Thermal resistance junction-ambient	50		°C/W

2 Electrical characteristics

$T_J = 25\text{ °C}$ unless otherwise specified

Table 3. Static characteristics

Symbol	Parameter	Test conditions	Min.	Typ.	Max.	Unit
$V_{(BR)CES}$	Collector-emitter breakdown voltage	$V_{GE} = 0\text{ V}, I_C = 2\text{ mA}$	650			V
$V_{CE(sat)}$	Collector-emitter saturation voltage	$V_{GE} = 15\text{ V}, I_C = 30\text{ A}$		1.55	2	V
		$V_{GE} = 15\text{ V}, I_C = 30\text{ A}, T_J = 125\text{ °C}$		1.65		
		$V_{GE} = 15\text{ V}, I_C = 30\text{ A}, T_J = 175\text{ °C}$		1.75		
$V_{GE(th)}$	Gate threshold voltage	$V_{CE} = V_{GE}, I_C = 1\text{ mA}$	5	6	7	V
I_{CES}	Collector cut-off current	$V_{GE} = 0\text{ V}, V_{CE} = 650\text{ V}$			25	μA
I_{GES}	Gate-emitter leakage current	$V_{CE} = 0\text{ V}, V_{GE} = \pm 20\text{ V}$			250	nA

Table 4. Dynamic characteristics

Symbol	Parameter	Test conditions	Min.	Typ.	Max.	Unit
C_{ies}	Input capacitance	$V_{CE} = 25\text{ V}, f = 1\text{ MHz}, V_{GE} = 0\text{ V}$	-	3659	-	pF
C_{oes}	Output capacitance		-	101	-	pF
C_{res}	Reverse transfer capacitance		-	76	-	pF
Q_g	Total gate charge	$V_{CC} = 520\text{ V}, I_C = 30\text{ A}, V_{GE} = 0\text{ to }15\text{ V}$ (see Figure 27. Gate charge test circuit)	-	149	-	nC
Q_{ge}	Gate-emitter charge		-	25	-	nC
Q_{gc}	Gate-collector charge		-	62	-	nC

Table 5. Switching characteristics (inductive load)

Symbol	Parameter	Test conditions	Min.	Typ.	Max.	Unit
$t_{d(on)}$	Turn-on delay time	$V_{CE} = 400\text{ V}$, $I_C = 30\text{ A}$, $R_G = 10\ \Omega$, $V_{GE} = 15\text{ V}$ (see Figure 26. Test circuit for inductive load switching)	-	37	-	ns
t_r	Current rise time		-	14.6	-	ns
$(di/dt)_{on}$	Turn-on current slope		-	1643	-	A/ μ s
$t_{d(off)}$	Turn-off delay time		-	146	-	ns
t_f	Current fall time		-	23	-	ns
$E_{on}^{(1)}$	Turn-on switching energy		-	151	-	μ J
$E_{off}^{(2)}$	Turn-off switching energy		-	293	-	μ J
E_{ts}	Total switching energy	-	444	-	μ J	
$t_{d(on)}$	Turn-on delay time	$V_{CE} = 400\text{ V}$, $I_C = 30\text{ A}$, $R_G = 10\ \Omega$, $V_{GE} = 15\text{ V}$, $T_J = 175\text{ }^\circ\text{C}$ (see Figure 26. Test circuit for inductive load switching)	-	35	-	ns
t_r	Current rise time		-	16.1	-	ns
$(di/dt)_{on}$	Turn-on current slope		-	1496	-	A/ μ s
$t_{d(off)}$	Turn-off-delay time		-	158	-	ns
t_f	Current fall time		-	65	-	ns
$E_{on}^{(1)}$	Turn-on switching energy		-	175	-	μ J
$E_{off}^{(2)}$	Turn-off switching energy		-	572	-	μ J
E_{ts}	Total switching energy	-	747	-	μ J	

1. Including the reverse recovery of the external SiC diode STPSC206W.

2. Including the tail of the collector current.

2.1 Electrical characteristics (curves)
Figure 1. Output characteristics ($T_J = 25^\circ\text{C}$)

Figure 2. Output characteristics ($T_J = 175^\circ\text{C}$)

Figure 3. Transfer characteristics

Figure 4. Collector current vs case temperature for TO-247 and TO-3P

Figure 5. Collector current vs case temperature for TO-3PF

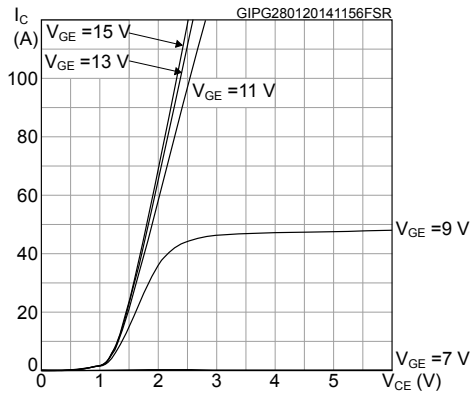
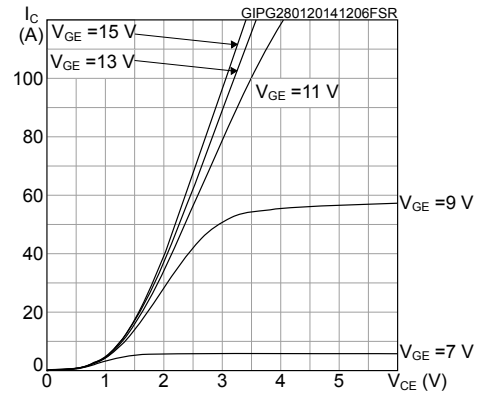
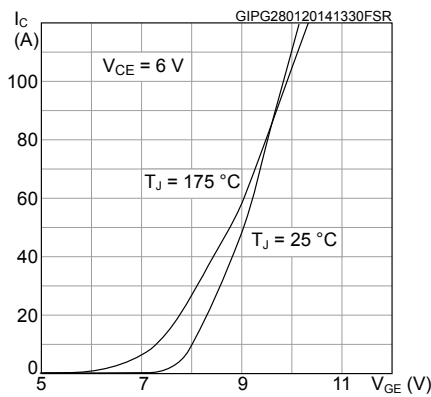
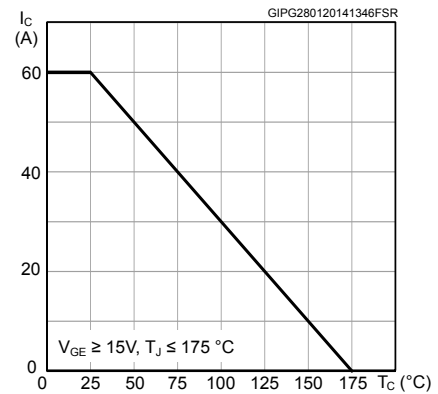
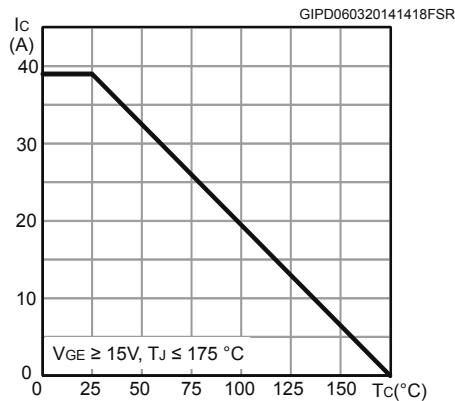
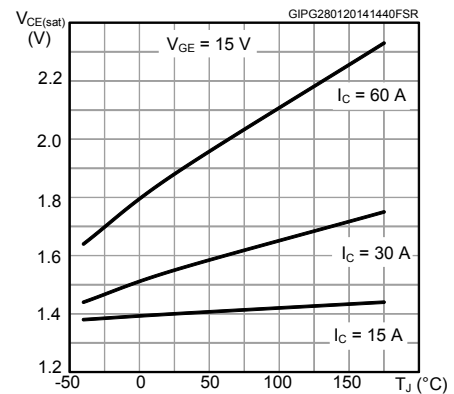
Figure 6. $V_{CE(sat)}$ vs junction temperature

Figure 7. Power dissipation vs case temperature for TO-247 and TO-3P

Figure 8. Power dissipation vs case temperature for TO-3PF

Figure 9. Forward bias safe operating area for TO-247 and TO-3P

Figure 10. Forward bias safe operating area for TO-3PF

Figure 11. Collector current vs switching frequency for TO-247 and TO-3P

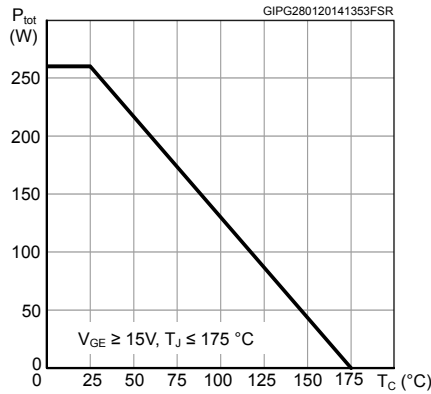
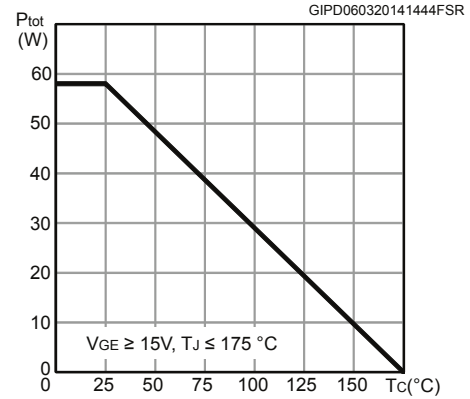
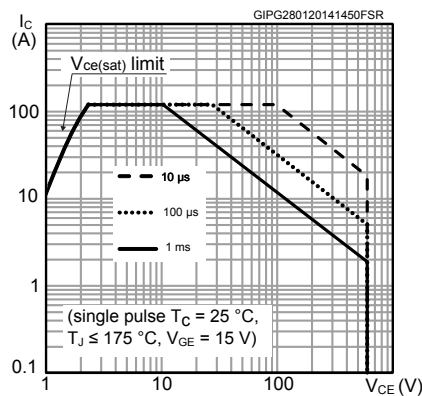
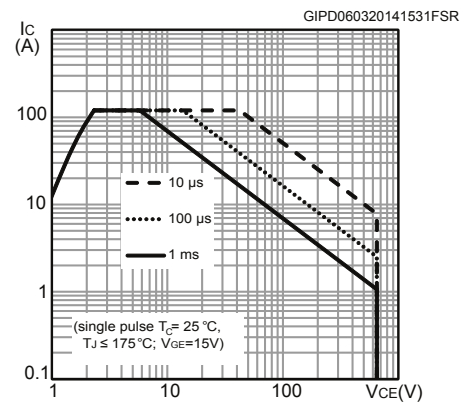
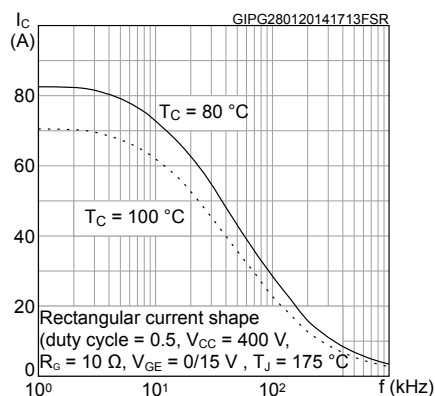
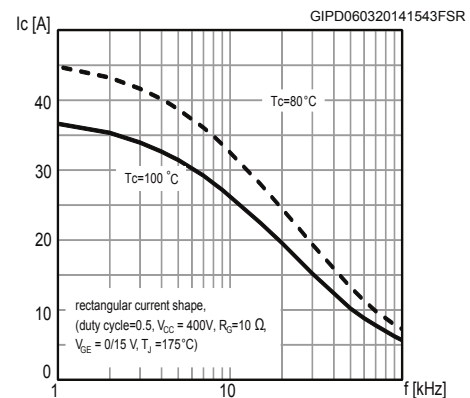
Figure 12. Collector current vs switching frequency for TO-3PF

Figure 13. Normalized $V_{GE(th)}$ vs junction temperature

Figure 14. Normalized $V_{(BR)CES}$ vs junction temperature

Figure 15. Switching energy vs temperature

Figure 16. Switching energy vs gate resistance

Figure 17. Switching energy vs collector current

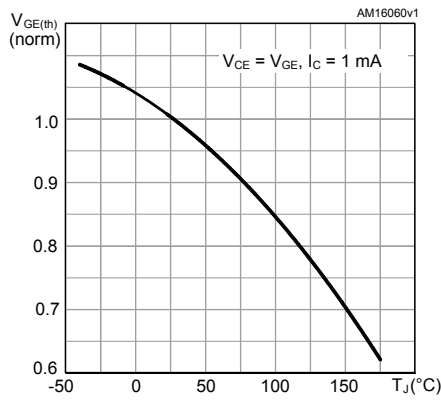
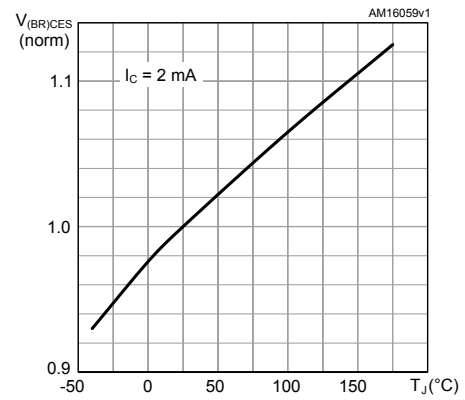
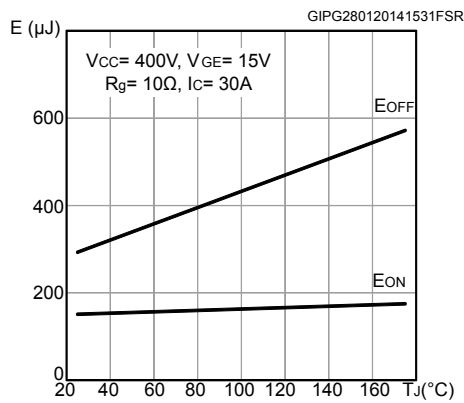
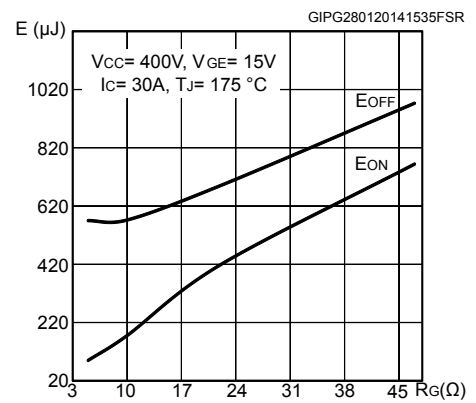
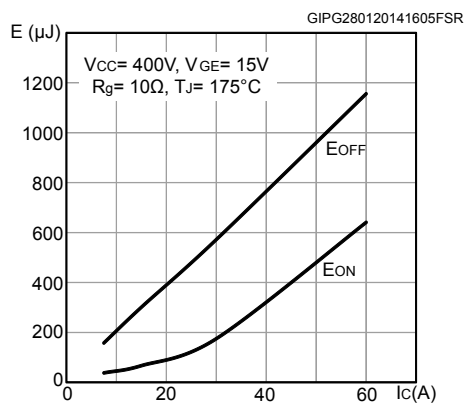
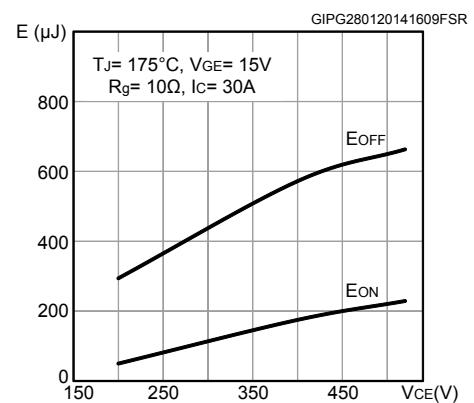
Figure 18. Switching energy vs collector emitter voltage

Figure 19. Switching times vs collector current

Figure 20. Switching times vs gate resistance

Figure 21. Capacitance variations

Figure 22. $V_{CE(sat)}$ vs collector current

Figure 23. Gate charge vs gate-emitter voltage

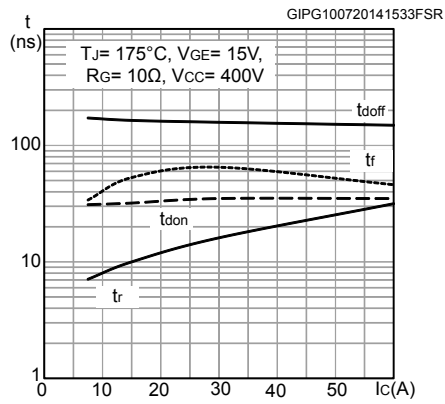
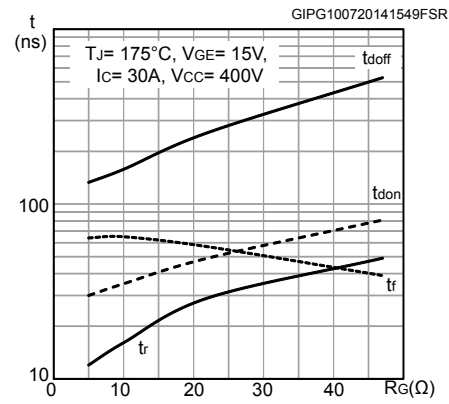
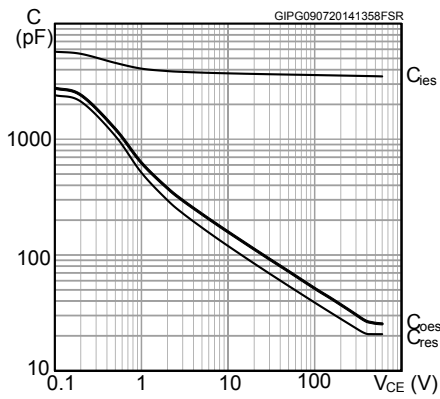
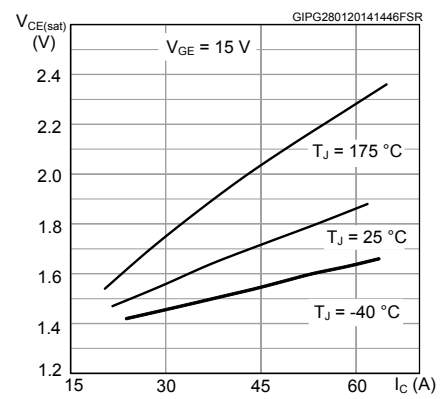
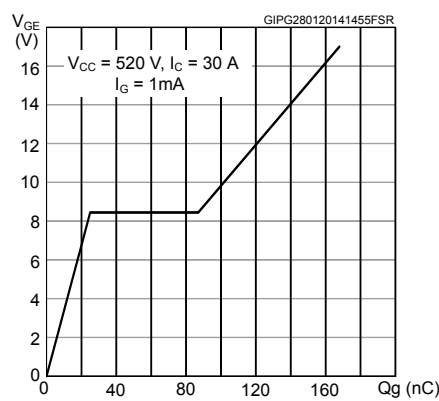
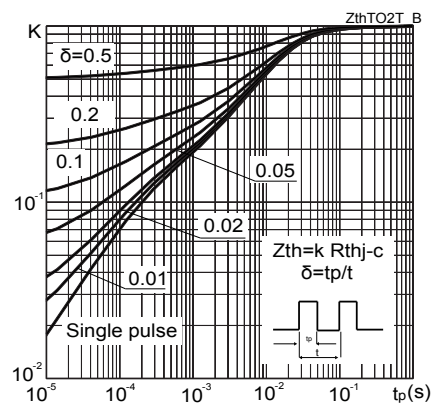
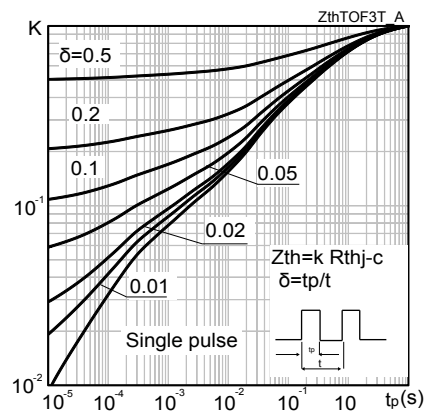
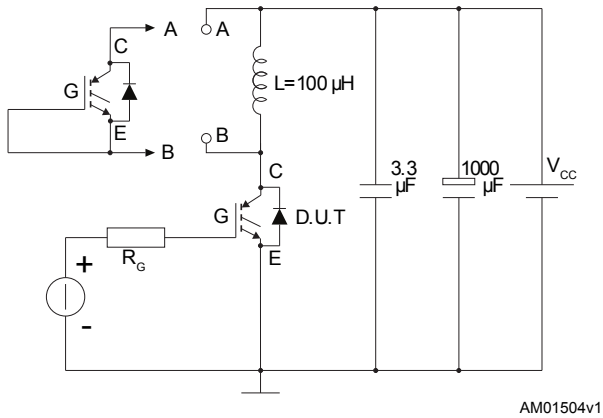
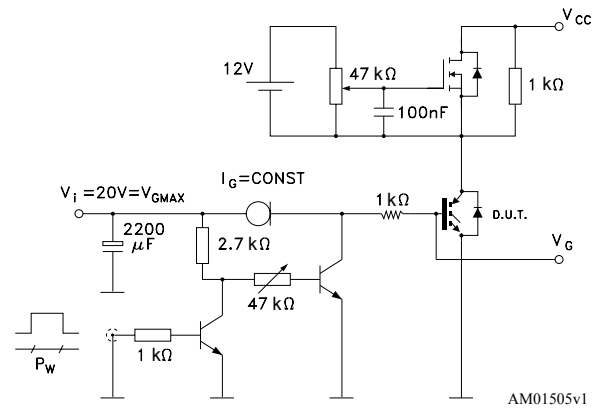
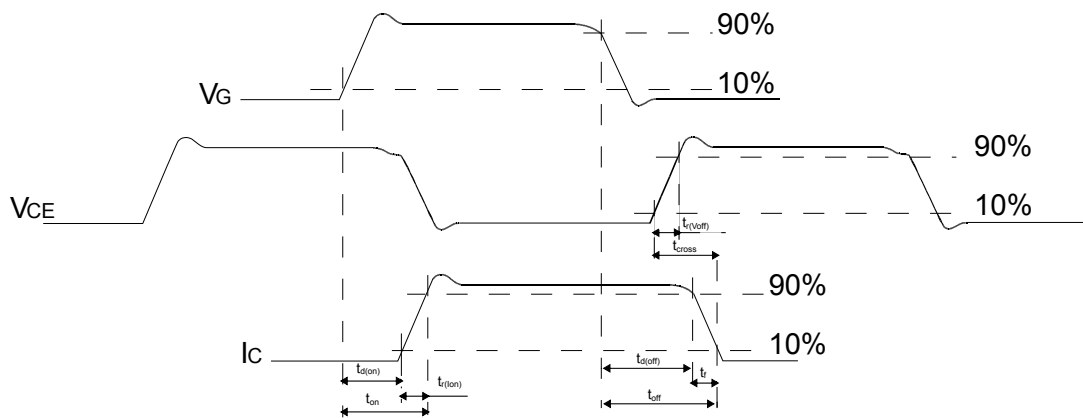
Figure 24. Thermal impedance for TO-247 and TO-3P

Figure 25. Thermal impedance for in TO-3PF



3 Test circuits

Figure 26. Test circuit for inductive load switching

Figure 27. Gate charge test circuit

Figure 28. Switching waveform

AM01506v1

4 Package information

In order to meet environmental requirements, ST offers these devices in different grades of **ECOPACK** packages, depending on their level of environmental compliance. ECOPACK specifications, grade definitions and product status are available at: www.st.com. ECOPACK is an ST trademark.

4.1 TO-3PF package information

Figure 29. TO-3PF package outline

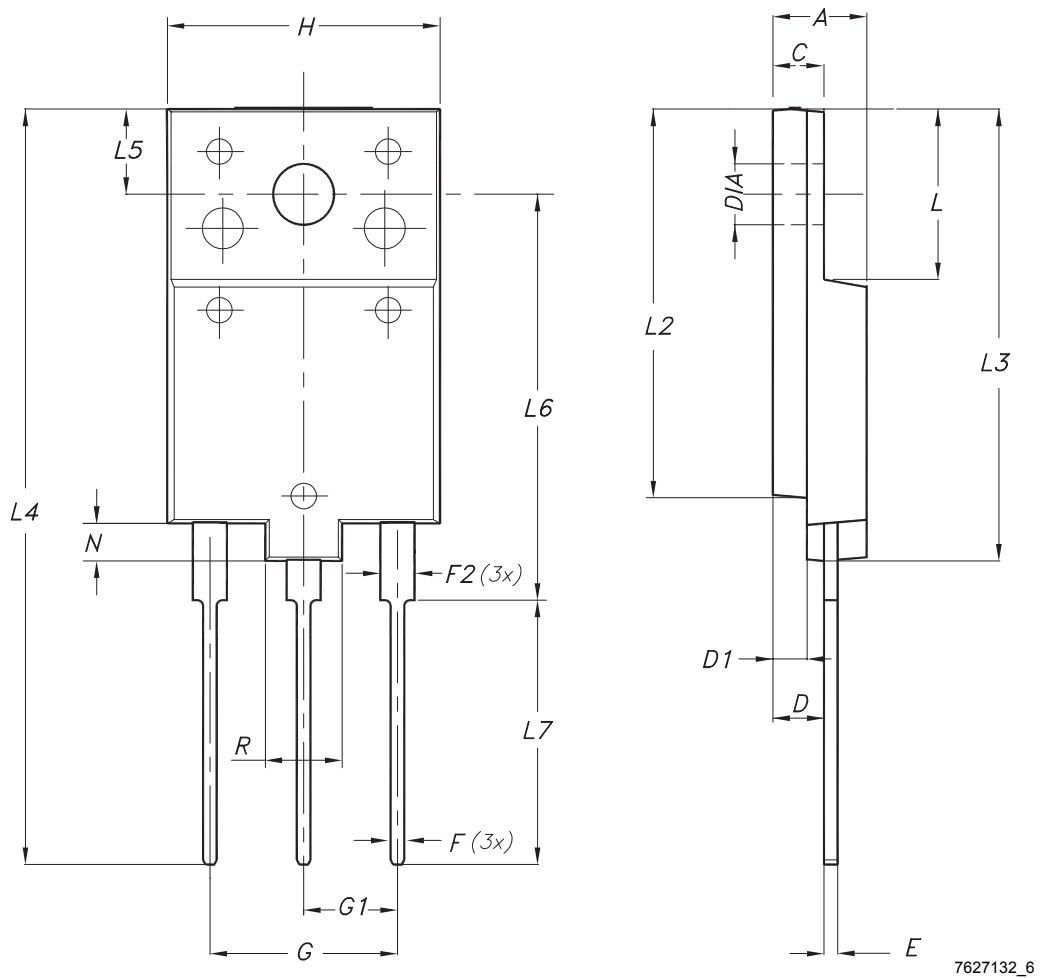

7627132_6

Table 6. TO-3PF mechanical data

Dim.	mm		
	Min.	Typ.	Max.
A	5.30		5.70
C	2.80		3.20
D	3.10		3.50
D1	1.80		2.20
E	0.80		1.10
F	0.65		0.95
F2	1.80		2.20
G	10.30		11.50
G1		5.45	
H	15.30		15.70
L	9.80	10.00	10.20
L2	22.80		23.20
L3	26.30		26.70
L4	43.20		44.40
L5	4.30		4.70
L6	24.30		24.70
L7	14.60		15.00
N	1.80		2.20
R	3.80		4.20
Dia	3.40		3.80

4.2 TO-247 package information

Figure 30. TO-247 package outline

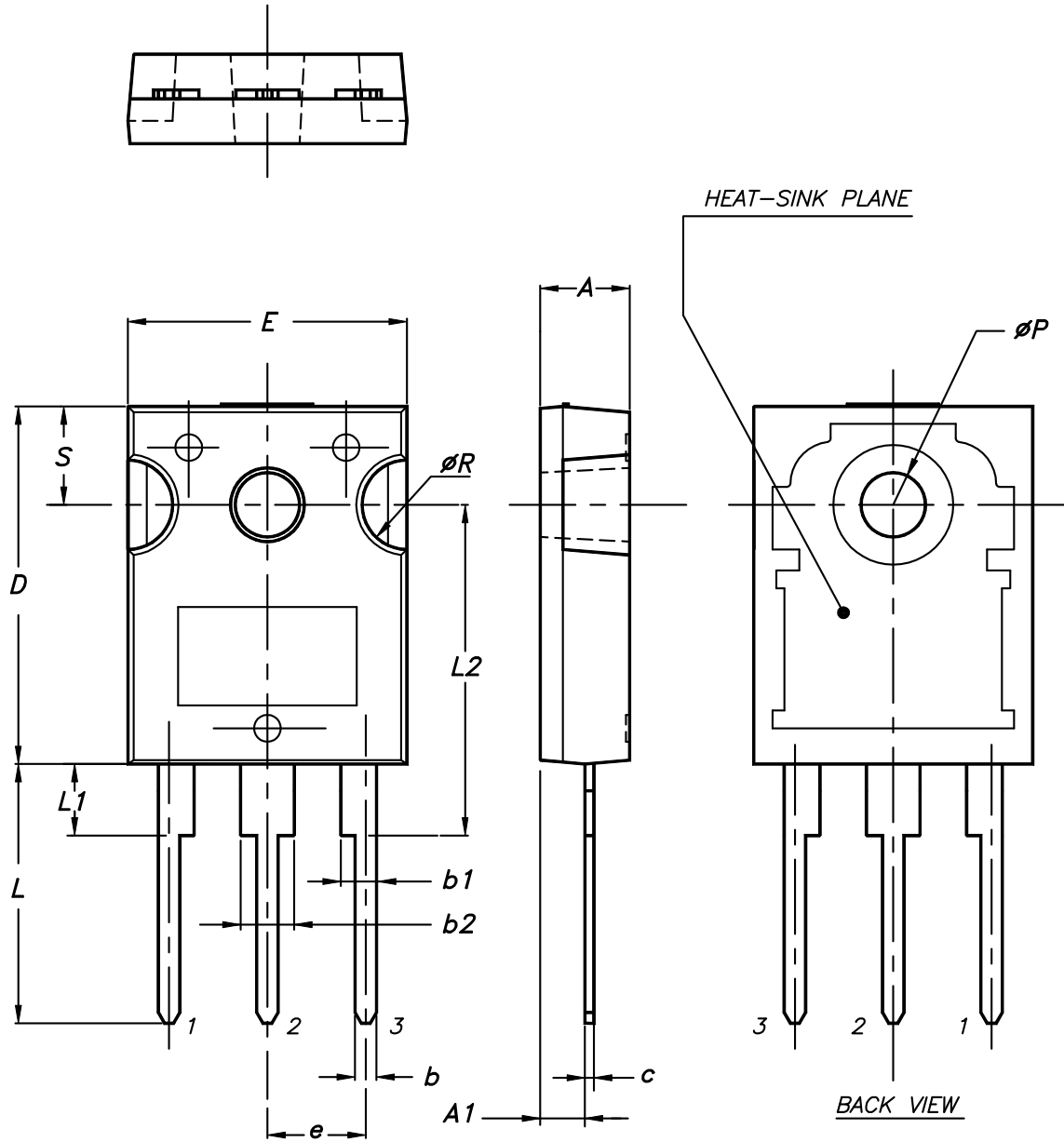

0075325_9

Table 7. TO-247 package mechanical data

Dim.	mm		
	Min.	Typ.	Max.
A	4.85		5.15
A1	2.20		2.60
b	1.0		1.40
b1	2.0		2.40
b2	3.0		3.40
c	0.40		0.80
D	19.85		20.15
E	15.45		15.75
e	5.30	5.45	5.60
L	14.20		14.80
L1	3.70		4.30
L2		18.50	
ØP	3.55		3.65
ØR	4.50		5.50
S	5.30	5.50	5.70

4.3 TO-3P package information

Figure 31. TO-3P package outline

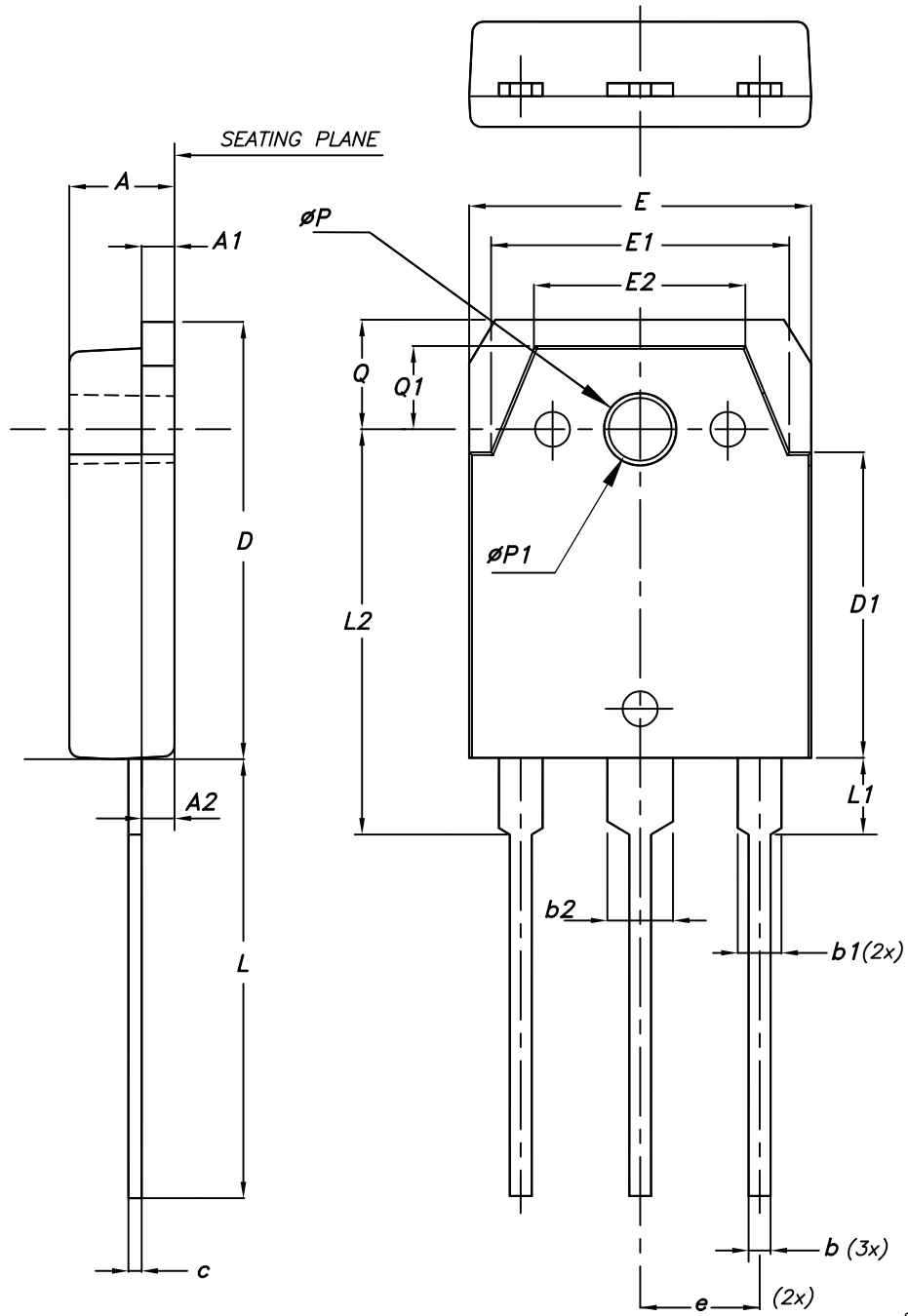

8045950_3

Table 8. TO-3P package mechanical data

Dim.	mm		
	Min.	Typ.	Max.
A	4.60	4.80	5.00
A1	1.45	1.50	1.65
A2	1.20	1.40	1.60
b	0.80	1.00	1.20
b1	1.80	2.00	2.20
b2	2.80	3.00	3.20
c	0.55	0.60	0.75
D	19.70	19.90	20.10
D1	13.70	13.90	14.10
E	15.40	15.60	15.80
E1	13.40	13.60	13.80
E2	9.40	9.60	9.90
e	5.15	5.45	5.75
L	19.80	20.00	20.20
L1	3.30	3.50	3.70
L2	18.20	18.40	18.60
ØP	3.30	3.40	3.50
ØP1	3.10	3.20	3.30
Q	4.80	5.00	5.20
Q1	3.60	3.80	4.00

5 Ordering information

Table 9. Order codes

Order code	Marking	Package	Packing
STGFW30H65FB	G30H65FB	TO-3PF	Tube
STGW30H65FB	GW30H65FB	TO-247	
STGWT30H65FB	GWT30H65FB	TO-3P	

Revision history

Table 10. Document revision history

Date	Revision	Changes
28-Jan-2014	1	Initial release.
24-Feb-2014	2	Updated units in <i>Table 6: Switching characteristics (inductive load)</i> for Ets, and updated note 1. Update <i>Figure 16: Switching losses vs temperature</i> , <i>Figure 17: Switching losses vs gate resistance</i> and <i>Figure 18: Switching losses vs collector current</i> . Updated title and features in cover page. Minor text changes.
10-Mar-2014	3	Added device in TO-3PF. Updated <i>Table 1: Device summary</i> , <i>Table 2: Absolute maximum ratings</i> , <i>Table 3: Thermal data</i> . Added <i>Figure 6: Collector current vs. case temperature for TO-3PF</i> , <i>Figure 9: Power dissipation vs. case temperature for TO-3PF</i> , <i>Figure 11: Forward bias safe operating area for TO-3PF</i> and <i>Figure 26: Thermal impedance for TO-3PF</i> . Updated <i>Section 4: Package information</i> .
20-May-2014	4	Updated <i>Table 2: Absolute maximum ratings</i> .
28-Jul-2015	5	Text and formatting changes throughout document Updated <i>Table 2: Absolute maximum ratings</i> Updated <i>Section 2.1: Electrical characteristics (curves)</i> Updated <i>Section 3: Test circuits</i> Updated <i>Section 4.2: TO-247 package information</i> Updated <i>Section 4.3: TO-3P package information</i>
27-Apr-2020	6	Updated applications in cover page. Updated <i>Table 9. Order codes</i> . Minor text changes.

Contents

1	Electrical ratings	2
2	Electrical characteristics	3
2.1	Electrical characteristics (curves)	5
3	Test circuits	10
4	Package information	11
4.1	TO-3PF package information	11
4.2	TO-247 package information	13
4.3	TO-3P package information	15
5	Ordering information	17
	Revision history	18