

Octal ± 90 V, ± 2 A, 3-level RTZ, high-speed ultrasound pulser

Data brief

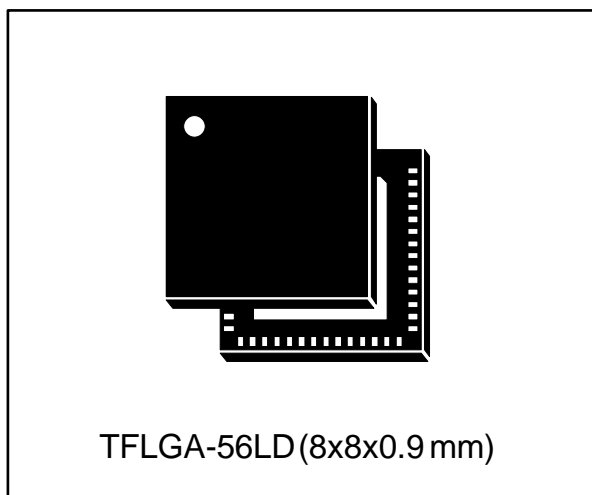

Features

- High-density ultrasound transmitter
- Two independent half-bridges per channel
- 0 to ± 90 V output voltage
- Power-up free
- Synchronization of the input signals (selectable) by an external clock
- Up to 20 MHz operating frequency
- Low-power, high-voltage, high-speed drivers
- 2 independently-supplied half bridges (shorted-option) for each channel, one dedicated to continuous wave (CW) mode
 - Main half bridge:
 - ± 2 A source and sink current
 - Down to 20 ps jitter
 - Low 2nd harmonic distortion
 - CW half bridge:
 - ± 0.3 A source and sink current
 - Down to 10 ps jitter
 - Very low power consumption

- Fully integrated real clamping-to-ground function
 - 8Ω synchronous active clamp
 - ± 2 A source and sink current
- Fully integrated TR switch
 - 8Ω ON resistance
 - Up to 300 MHz BW
 - Current consumption down to 10 μ A in RX phase
 - Receiver multiplexing function
- 1.8 V to 3.6 V CMOS logic interface
- Auxiliary integrated circuits
 - Noise blocking diodes
 - Anti-leakage on output node
 - Fully self-biasing architecture
 - Thermal protection
- Latch-up free due to HV SOI technology
- Very few external passive components or supplies needed

Applications

- Medical ultrasound imaging
- Pulse waveform generator
- NDT ultrasound transmission
- Piezoelectric transducer drivers
- Point-of-care ultrasound imaging equipment

Table 1: Device summary

Order code	Package	Packing
STHV800L	TFLGA-56LD	Tape and reel

1 Description

The STHV800 is an octal, monolithic, high-voltage and high-speed pulse generator. It is designed for medical ultrasound applications, but can be used for other piezoelectric, capacitive or MEMS transducers.

The device integrates a controller logic interface circuit (compatible with both 1.8 V and 3.3 V input signals), level translators, MOSFET gate drivers, noise blocking diodes, and high power P-channel and N-channel MOSFETs as the output stage for each channel. These MOSFETs are capable of providing more than 2 A of peak output current. Each channel has a dedicated bridge in order to reduce power dissipation and jitter during continuous wave mode (peak current is limited to 0.3 A). This CW bridge has dedicated power supplies (HV_CW) which are fully independent on the main HV supplies.

These HV_CW supplies can be shorted to the HV supplies. The fundamental structure of each channel also consists of active clamping to ground circuitry, anti-leakage and anti-memory block, a thermal sensor to protect the device and an integrated TR-switch (just 8 Ω as equivalent resistor) to connect the HV output to its LV output, guaranteeing strong decoupling during the transmission phase.

The eight independent T/R switches can be used in both a dedicated RX chain per channel or in a multiplexing configuration.

The clamp circuit has a current capability up to 2 A and works directly on the output pin, carrying this node exactly to zero. This feature allows minimized injection change during the transition from clamp to RX state.

In addition, the STHV800 includes self-biasing circuitry which allows very low power consumption during the RX phase (down to 200 μ W global power dissipation) and thermal shutdown block sensing by an external dedicated pin (THSD).

One of the main benefits of this device is that it requires very few external components: only decoupling capacitors on the HV and LV supplies, and a resistor to pull up the THSD pin (moreover, this resistor can be shared by many devices).

Each channel is driven independently by only 2 digital bits, which in CW mode become one bit. An external clock can be used with the STHV800 to synchronize all the input signals. This feature, however, is optional: if the CK pin is tied to ground the device works in asynchronous mode.

Figure 1: STHV800 internal block diagram

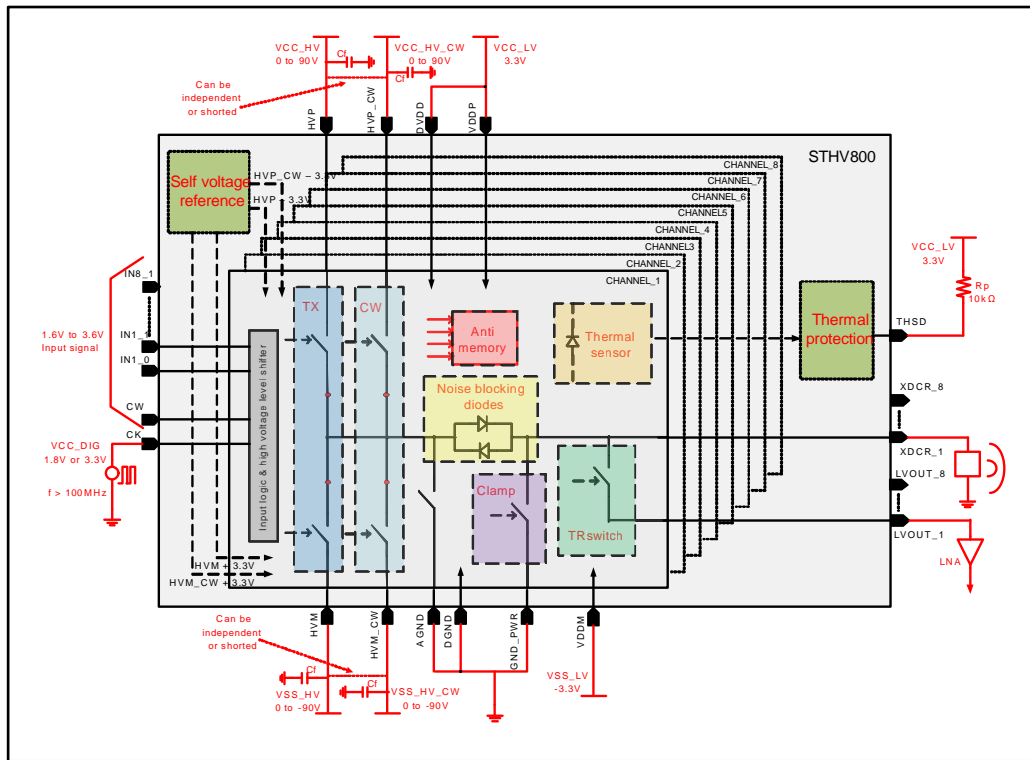
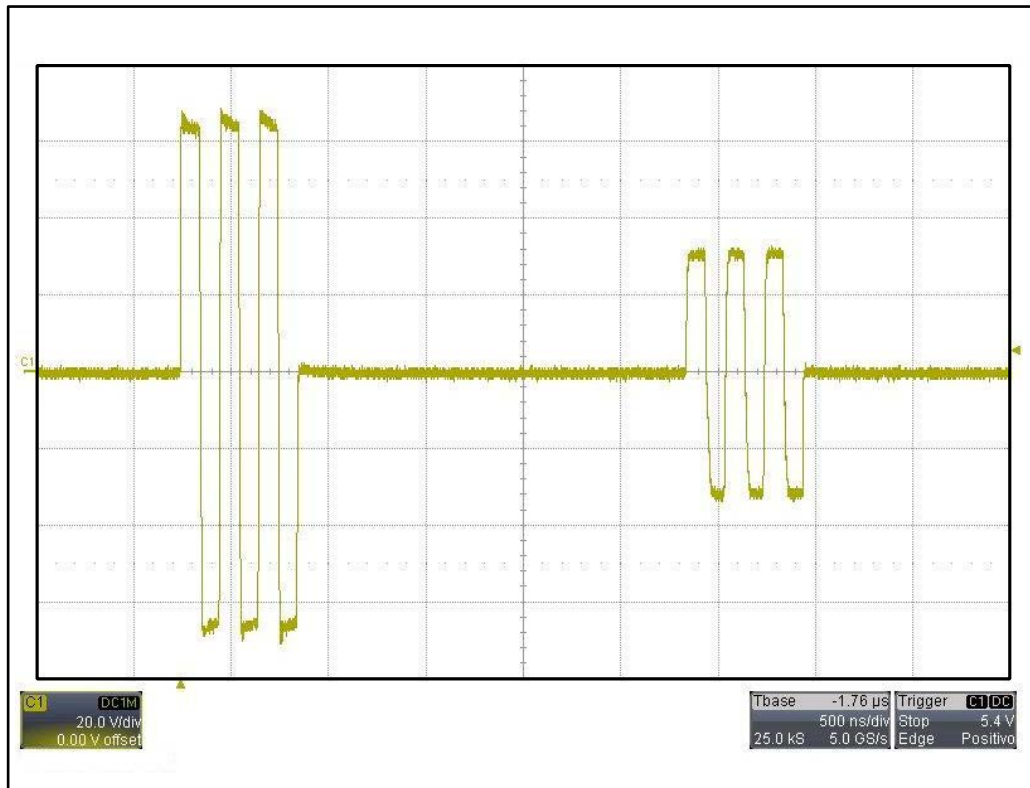

Figure 2: XDCR output in DUPLEX mode from single channel - PW and CW composition example



2 Revision history

Table 2: Document revision history

Date	Revision	Changes
21-Mar-2014	1	Initial release.
07-Apr-2014	2	Changed order code from STHV800QTR to STHV800L in Table 1: Device summary