

## Miniature KNX transceiver with voltage regulators and microcontroller support

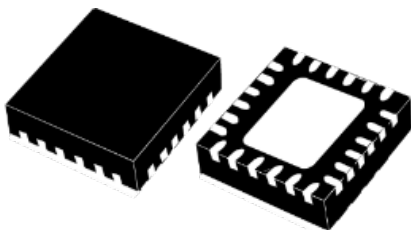

VFQFPN24 (4 x 4 x 1.0 mm, 0.5 mm pitch)

### Features

- Very thin fine pitch 4 x 4 mm VQFNPN24 package
- KNX certified, KNX TP1-256 supported
- Easy interface to microcontroller
- Very small system solution
- Two integrated voltage regulators for external use in application
  - Selectable 3.3 V / 5 V - 20 mA linear regulator
  - Adjustable 1 V to 12 V - 150 mA high- efficiency DC/DC step down switching converter
- KNX bus power extractor supporting bus current up to 30 mA
- Adjustable KNX bus current slew rate  $dl/dt$
- No crystal required
- Operating temperature range -40 °C to +85 °C

### Applications

- KNX twisted pair network (KNX TP1-256)

### Description

The STKNX is a transceiver device for KNX TP communication. The small package and few external components enable very compact KNX node design.

The simple interface to the microcontroller allows easy replacement of physical layer discrete component implementations.

The STKNX device features two integrated voltage regulators for external use in the application: the selectable 3.3 V / 5 V - 20 mA linear regulator and the adjustable 1 V to 12 V - 150 mA high-efficiency DC/DC step down switching converter.

The integrated KNX bus power extractor supports bus current up to 30 mA to power external devices and the STKNX transceiver's own power needs, while limiting the bus current slew rate according to KNX specifications.

The STKNX ensures safe coupling to the bus and provides the bus monitoring warning for the loss of bus power.

Product status link		
STKNX		
Product summary		
Order code	STKNX	STKNXTR
Package	VFQFPN24	
Packing	Tube	Tape & Reel
Product label		
		

# 1 Typical application circuit and block diagram

## 1.1 Typical application circuit

Figure 1. Typical application circuit, buck converter enabled, linear regulator supplied by impedance modulator

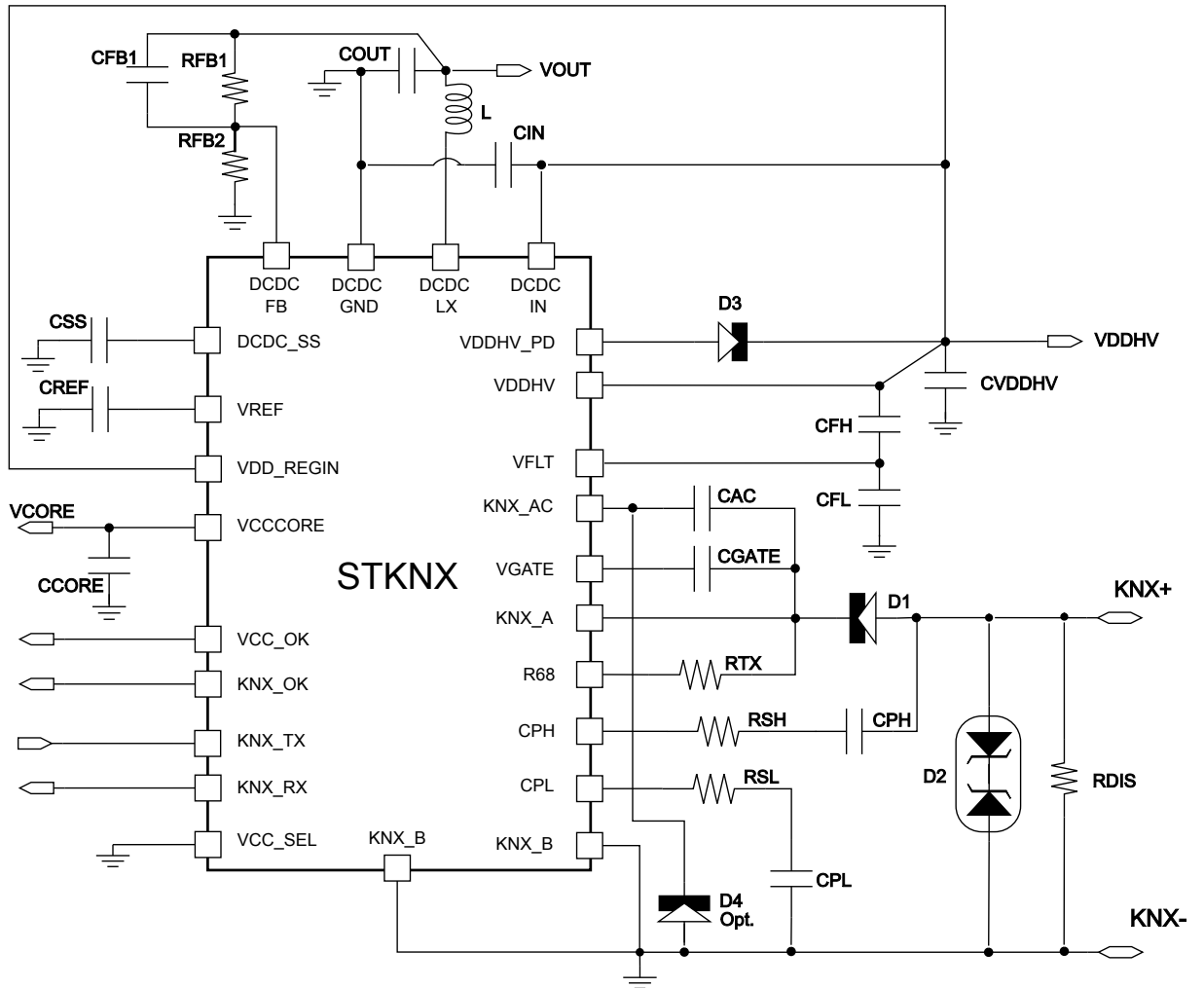

Note: *VOUT range 1 V - 12 V.*  
*VCORE selectable to 3.3 V / 5 V through VCC\_SEL (3.3 V in the example).*

**Figure 2.** Typical application circuit, buck converter enabled, linear regulator supplied by buck converter

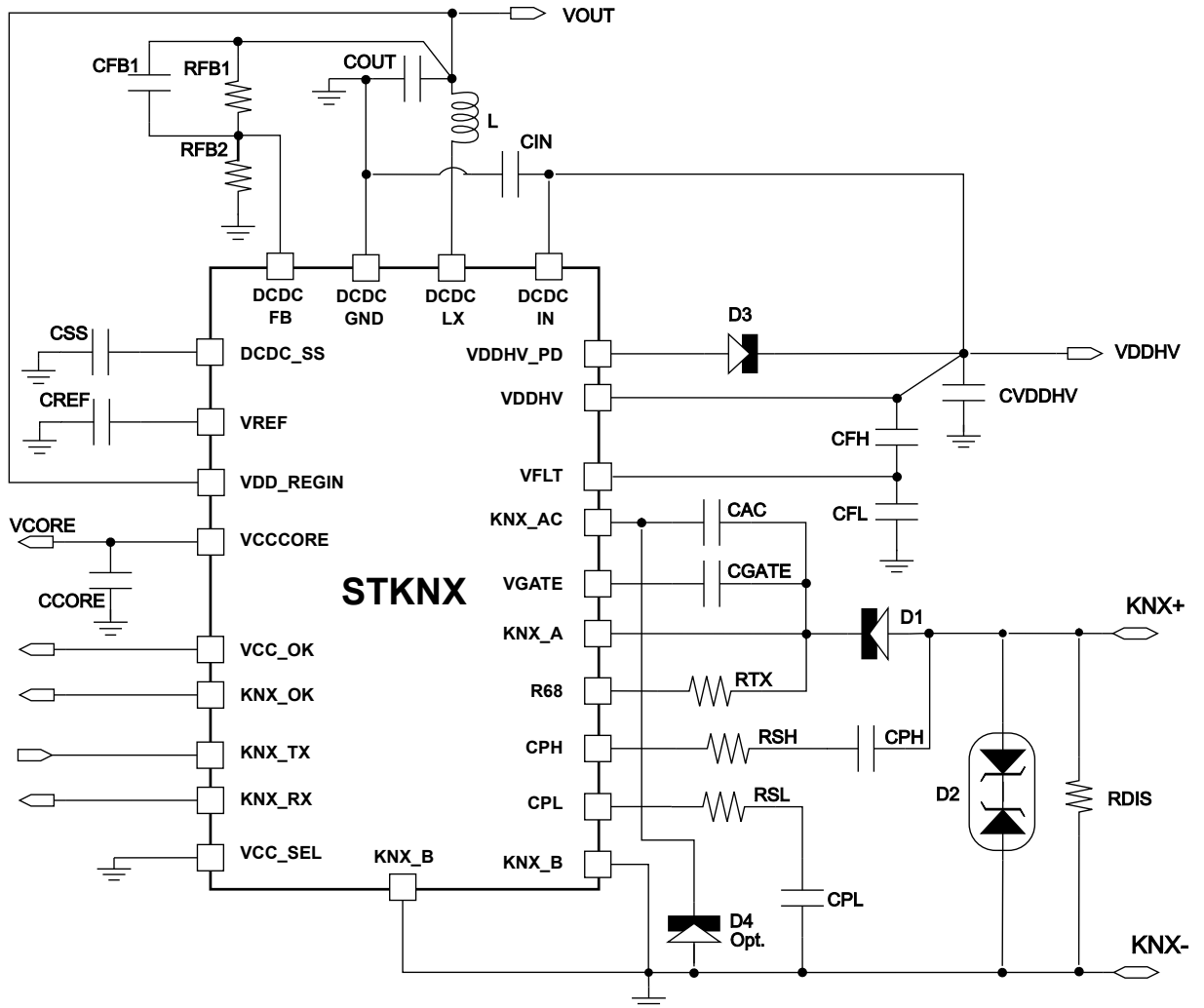

*Note:* The VOUT level needs to be compliant with VDD\_REGIN recommended operating conditions. VCORE selectable to 3.3 V / 5 V through VCC\_SEL (3.3 V in the example).

**Figure 3. Typical application circuit, buck converter disabled**

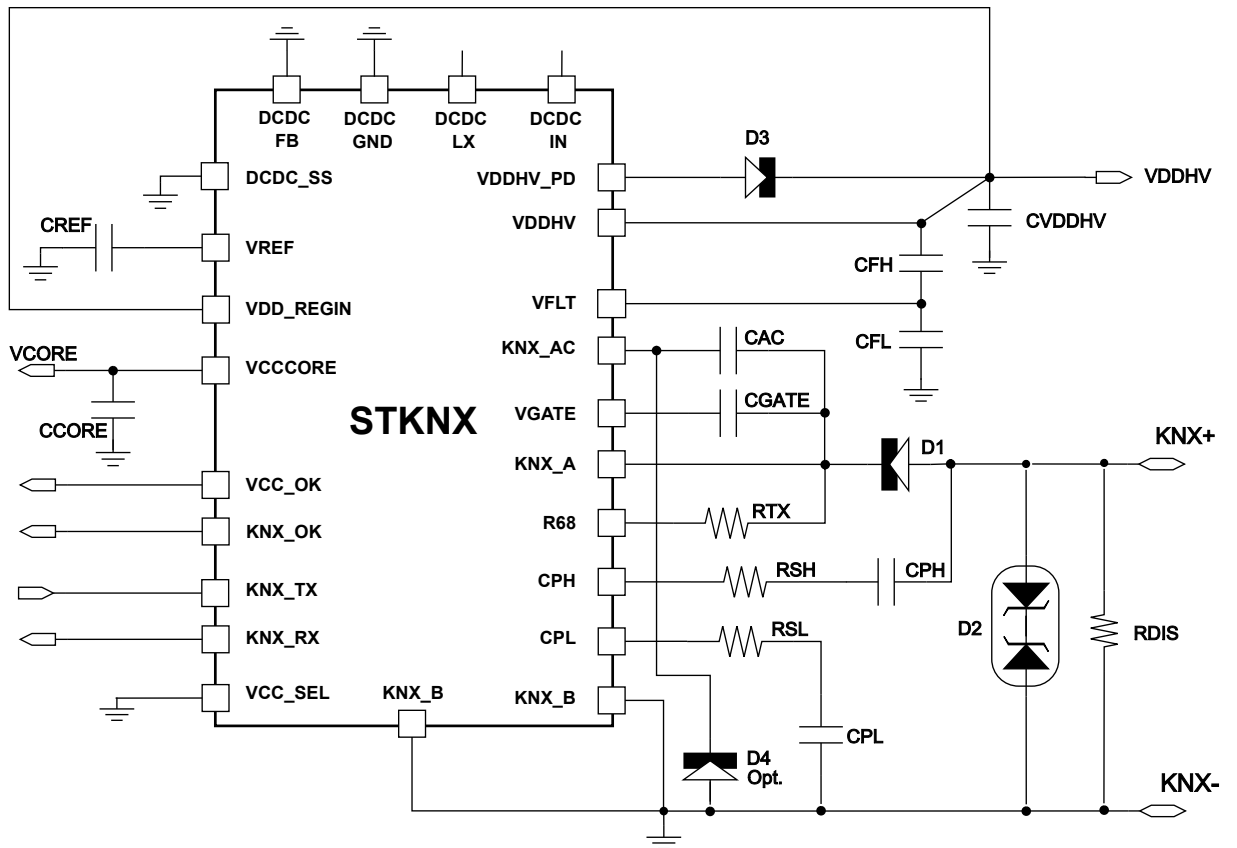

*Note:* VCORE selectable to 3.3 V / 5 V through VCC\_SEL (3.3 V in the example).

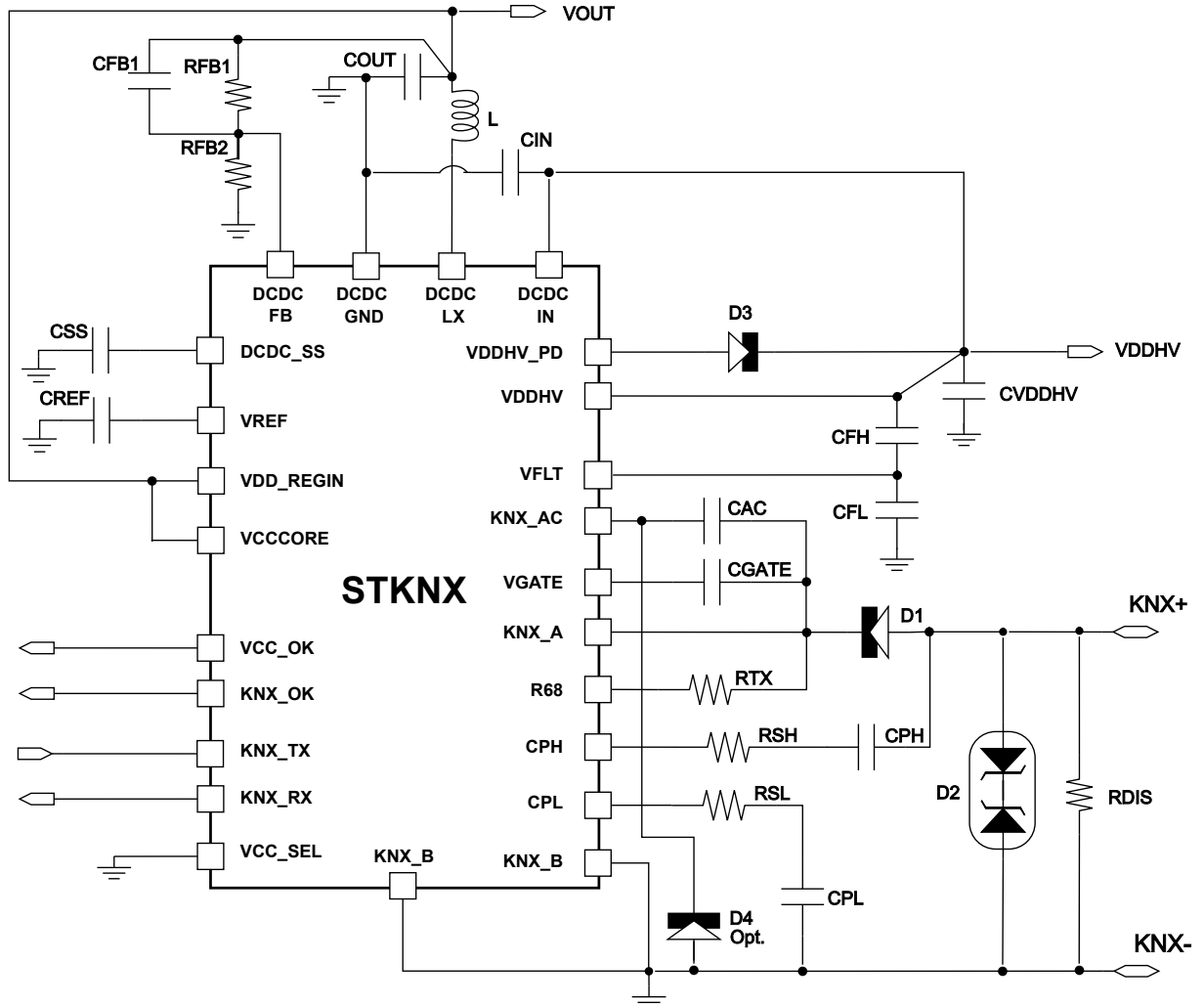
**Figure 4. Typical application circuit, linear regulator disabled**

*Note:* The VOUT level needs to be compliant with VCCCORE recommended operating conditions. VCC\_SEL needs to be set according to the VCCCORE level (3.3 V in the example).

**Table 1. External components typical value**

Reference	Type	Typ. value	Rating	Description
<b>Capacitors</b>				
CPH	MLCC	100 nF	$V_{RATED} \geq 50$ V	Equalizer storage capacitor
CPL	MLCC	100 nF	$V_{RATED} \geq 50$ V	Equalizer storage capacitor
CGATE	MLCC or electrolytic	10 $\mu$ F - 47 $\mu$ F	$V_{RATED} \geq 10$ V	Impedance modulator storage capacitor - see Table 7
CAC	MLCC	10 nF	$V_{RATED} \geq 50$ V	Bus AC coupling capacitor
CVDDHV	Electrolytic	$\geq 100$ $\mu$ F	$V_{RATED} \geq 35$ V	Impedance modulator output bulk capacitor - see Table 7
CFH	MLCC	47 nF	$V_{RATED} \geq 35$ V	Impedance modulator compensation capacitor

Reference	Type	Typ. value	Rating	Description
CFL	MLCC	47 nF	$V_{RATED} \geq 35 \text{ V}$	Impedance modulator compensation capacitor
CIN	MLCC	10 $\mu\text{F}$	$V_{RATED} \geq 35 \text{ V}$	Buck converter input decoupling capacitor
COUT	MLCC	22 $\mu\text{F}$	$V_{RATED} > V_{OUT}$	Buck converter output capacitor
CSS	MLCC	10 nF - 470 nF	$V_{RATED} \geq 6.3 \text{ V}$	Buck converter soft-start time programming capacitor - see Eq. (3)
CREF	MLCC	470 nF	$V_{RATED} \geq 35 \text{ V}$	VREF decoupling capacitor
CCORE	MLCC	4.7 $\mu\text{F}$	$V_{RATED} \geq 6.3 \text{ V}$	Linear regulator output capacitor
CFB1	MLCC	$1/(2\pi * RFB1 * 28 \text{ kHz})$ NM if RFB1 = 0 $\Omega$	$V_{RATED} \geq 16 \text{ V}$	Buck converter compensation capacitor
<b>Resistors</b>				
RDIS	Resistor	4.7 M $\Omega$	-	Reverse polarity discharging resistor
RSH	Resistor	1 k $\Omega$	-	Series resistor to CPH
RSL	Resistor	1 k $\Omega$	-	Series resistor to CPL
RTX	Resistor	68 $\Omega$	$P_{DISS} \geq 1 \text{ W}$	Tx current limiting resistor
RFB1	Resistor	$(V_{OUT} / 1 \text{ V} - 1) * RFB2$ 0 $\Omega$ for $V_{OUT} = 1 \text{ V}$	-	Buck converter output voltage adjusting resistor
RFB2	Resistor	10 k $\Omega$ typ. (< 100 k $\Omega$ ) NM for $V_{OUT} = 1 \text{ V}$	-	Buck converter output voltage adjusting resistor
<b>Inductors</b>				
L	Power inductor	33 $\mu\text{H}$	$I_R > 150 \text{ mA}$ $I_{SAT} > 550 \text{ mA}$	Buck converter output inductor
<b>Diodes</b>				
D1	Diode	LL4148 or equivalent	$V_{BR} > 50 \text{ V}$ $V_F (50 \text{ mA}) < 1 \text{ V}$	Input diode (protection from reverse polarity connection)
D2	TVS	SMAJ40CA or lower clamping voltage	-	Transient voltage suppressor diode
D3	Diode	LL4148 or equivalent	$V_{BR} > 50 \text{ V}$ $V_F (50 \text{ mA}) < 1 \text{ V}$	Output diode
D4	Diode	LL4148 or equivalent	$V_{BR} > 50 \text{ V}$ $V_F (50 \text{ mA}) < 1 \text{ V}$	Optional KNX_AC clamping diode. Recommended for noise immunity improvement in noisy environment.

## 1.2 Block diagram

Figure 5. STKNX Block diagram

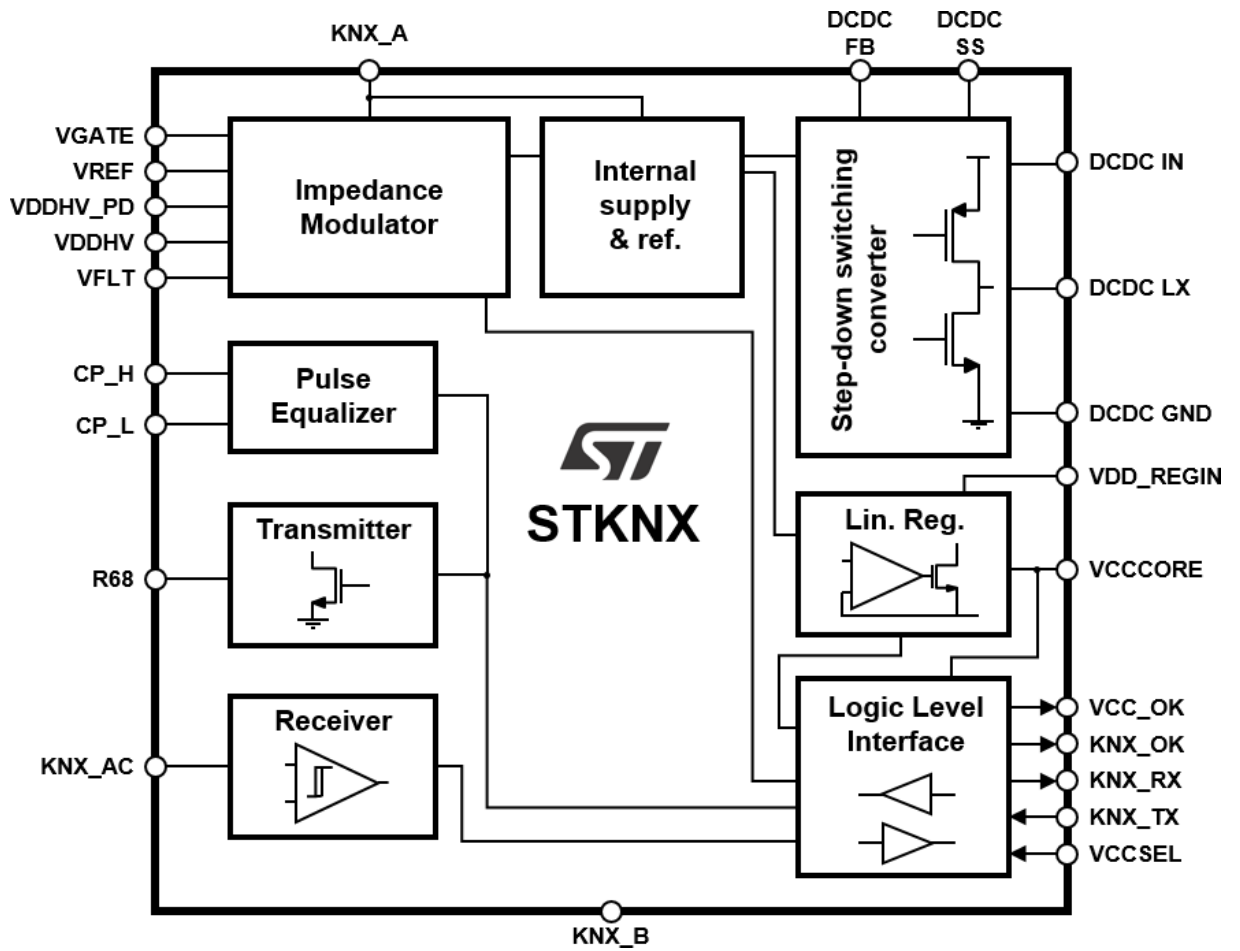

## 2 Pin connection and pin description

### 2.1 Pin connection

Figure 6. Pin connection (top view)

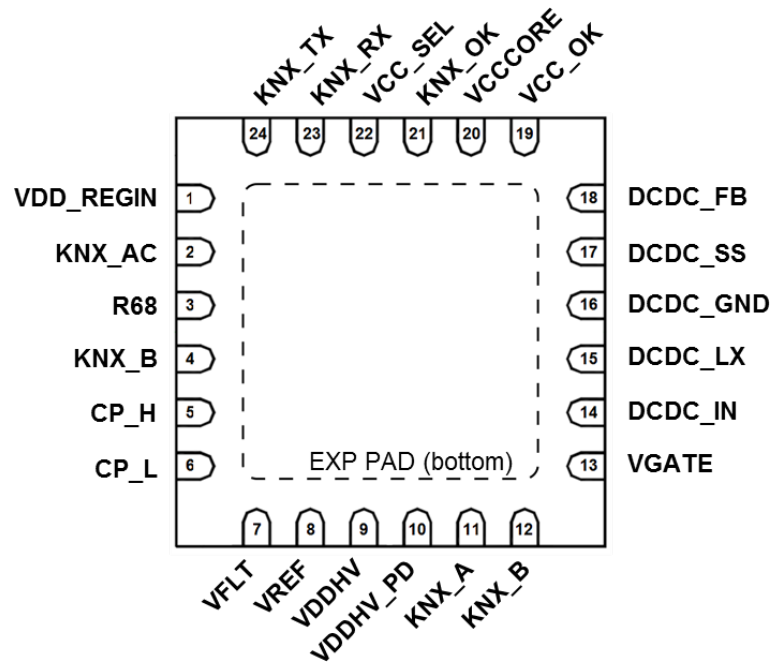

### 2.2 Pin description

Table 2. STKNX Pin description

Pin	Pin name	Function
1	VDD_REGIN	Linear regulator supply input. Short to VCCCORE to disable the linear regulator and supply VCCCORE externally.
2	KNX_AC	BUS AC-coupled sense for the Rx input and Tx feedback. DC biased to 9.7 V typ.
3	R68	KNX transmitter output
4	KNX_B	Analog ground
5	CP_H	Equalization cap connection to KNX supply (KNX+)
6	CP_L	Equalization cap connection to KNX ground (KNX-)
7	VFLT	Impedance modulator compensation
8	VREF	Impedance modulator reference
9	VDDHV	VDDHV supply input and impedance modulator feedback
10	VDDHV_PD	Impedance modulator power output
11	KNX_A	KNX power supply input (KNX+)
12	KNX_B	Analog ground
13	VGATE	Impedance modulator storage capacitor connection
14	DCDC_IN	Step down converter supply input. Short to ground or leave floating to disable the switching converter.



Pin	Pin name	Function
15	DCDC_LX	Step down converter switching output
16	DCDC_GND	Step down converter power ground
17	DCDC_SS	Step down converter soft-start programming pin
18	DCDC_FB	Step down converter feedback input. Sets output voltage (1 V - 12 V range) through the resistor divider.
19	VCC_OK	VCCCORE power good CMOS digital output
20	VCCCORE	Linear regulator output (3.3 V / 5 V selectable). Supply voltage for digital I/O.
21	KNX_OK	KNX bus power good CMOS digital output
22	VCC_SEL	Selects linear regulator output voltage. Internally pulled down (6 $\mu$ A typ.). Tie to VCCCORE to select 5 V. Short to ground or leave floating to select 3.3 V.
23	KNX_RX	Receiver CMOS digital output
24	KNX_TX	Transmitter digital input. Internally pulled down (6 $\mu$ A typ.).
-	Exposed pad	Connect to analog ground. For thermal optimization, maximize the area of the ground layer on which the exposed pad is soldered and provide good thermal connection with the bottom ground layer through vias.

### 3 Thermal characteristics

**Table 3. Thermal characteristics**

Symbol	Parameter	Test condition	Value	Unit
$T_J$	Maximum operating junction temperature	-	110	°C
$T_{AMB}$	Operating ambient temperature	-	-40 to 85	°C
$T_{STG}$	Storage temperature	-	-50 to 150	°C
$R_{thJA}$	Thermal resistance junction to ambient, steady state	Mounted on a 2s2p PCB, with a dissipating surface connected through vias on the bottom side of the PCB.	35	°C/W

## 4 Electrical specifications

### 4.1 Absolute maximum ratings

**Table 4. Absolute maximum ratings**

Symbol	Parameter	Min.	Max.	Unit
KNX_A	KNX supply input	-0.3	45	V
VDD_REGIN	Linear regulator supply input	-0.3	40	V
VDDHV	VDDHV supply input and impedance modulator feedback	-0.3	40	V
VREF	Impedance modulator reference	-0.3	40	V
KNX_B, DCDC_GND	Variation between different ground pins	-0.3	0.3	V
CP_H	Equalizing cap. high	-0.3	KNX_A + 0.3	V
CP_L	Equalizing cap. low	-0.3	KNX_A + 0.3	V
R68	KNX transmitter output	-0.3	KNX_A + 0.3	V
KNX_AC	BUS AC-coupled sense	-0.3	KNX_A + 0.3	V
VDDHV_PD	Impedance modulator power output	-0.3	KNX_A + 0.3	V
VGATE	Impedance modulator coupling cap.	Max. (-0.3, KNX_A - 7.2)	KNX_A + 0.3	V
VCCCORE	Linear reg. output. I/O supply.	-0.3	5.5	V
KNX_TX	Transmitter digital input	-0.3	Min. (5.5, VCCCORE + 0.3)	V
KNX_RX	Transmitter digital output	-0.3	Min. (5.5, VCCCORE + 0.3)	V
KNX_OK	KNX bus power good	-0.3	Min. (5.5, VCCCORE + 0.3)	V
VCC_SEL	3.3 V / 5 V selection for linear reg.	-0.3	Min. (5.5, VCCCORE + 0.3)	V
VCC_OK	VCCCORE power good	-0.3	Min. (5.5, VCCCORE + 0.3)	V
VFLT	Impedance modulator compensation	-0.3	5.5	V
DCDC_IN	Step down converter input	-0.3	40	V
DCDC_LX	Step down converter switching node	-0.3	Min. (40, DCDC_IN + 0.3)	V
DCDC_FB	Step down converter feedback	-0.3	3.6	V
DCDC_SS	Step down converter soft-start programming pin	-0.3	3.6	V

### 4.2 Recommended operating conditions

**Table 5. Recommended operating conditions**

Symbol	Parameter	Test condition	Min.	Max.	Unit
KNX_A	KNX supply input <sup>(1)</sup>	-	20	32	V
VCCCORE	I/O supply and linear reg. output	-	3	5.5	V
DCDC_IN	Step down converter input	-	13	32	V
VDD_REGIN	Linear regulator supply input <sup>(2)</sup>	VCC_SEL shorted to GND	6.8	32	V
		VCC_SEL shorted to VCCCORE	8.5	32	V

Symbol	Parameter	Test condition	Min.	Max.	Unit
$I_{VDDHV\_PD}$	Continuous output current from VDDHV pin <sup>(3)</sup>	-	-	30	mA
$I_{REG}$	Continuous output current from VCCCORE pin <sup>(3)</sup>	-	-	20	mA
$I_{DCDC}$	Continuous output current from DCDC switching converter <sup>(3)</sup>	-	-	150	mA

1. Indicates DC value. With the active and equalization pulse bus voltage must be between 11 V and 45 V.
2. Short VDD\_REGIN to VCCCORE to disable the internal linear regulator and provide VCCCORE voltage externally.
3. The maximum current capability refers to the voltage regulator only. The usable current capability can be limited by the KNX bus current consumption specification.

### 4.3 Electrical characteristics

**Table 6. Electrical characteristics**

Parameters given for a device operating within the recommended operating conditions, unless otherwise specified. Typical values are referred to  $T_J = 27\text{ °C}$ .

Symbol	Parameter	Conditions	Min.	Typ.	Max.	Unit
<b>Power supply</b>						
$V(KNX\_A)$	DC supply voltage on KNX_A pin	Excluding active and equalization pulse	20	-	32	V
$I(KNX\_A)$	Bus current consumption, no load	$V(KNX\_A) = 32\text{ V}$ , no activity on bus, no transmission, no external load	-	1	-	mA
	Bus current consumption, 30 mA load	$V(KNX\_A) = 32\text{ V}$ , no activity on bus, no transmission, 30 mA load on VDDHV rail (including linear regulator and switching converter)	-	31	-	mA
$KNX\_OK_{RIS}(VREF)$	KNX_OK rising threshold referred to VREF voltage	VREF rising	-	-	13.5	V
$KNX\_OK_{FALL}(VREF)$	KNX_OK falling threshold referred to VREF voltage	VREF falling	9.7	-	-	V
$KNX\_OK_{HYST}(VREF)$	KNX_OK hysteresis referred to VREF voltage	-	-	1.4	-	V
$KNX\_OK_{RIS}(KNX\_A)$	KNX_OK rising threshold referred to KNX_A DC voltage	KNX_A rising slowly, VREF settled	-	-	18.5	V
<b>Impedance modulator</b>						
VDDHV drop	$V(KNX\_A) - V(VDDHV)$ voltage drop	$V(KNX\_A) = 20\text{ V DC}$ $I_{LOAD} = 5\text{ mA}$ D3 = LL4148 or equivalent	-	-	6.5	V
VDDHV drop	$V(KNX\_A) - V(VDDHV)$ voltage drop	$V(KNX\_A) = 20\text{ V DC}$ , $I_{LOAD} = 30\text{ mA}$ , D3 = LL4148 or equivalent	-	-	7.2	V
VREF drop	$V(KNX\_A) - V(REF)$ voltage drop	$V(KNX\_A) = 20\text{ V DC}$ , VREF settled	3	4.3	5	V
<b>VCCCORE voltage and linear regulator</b>						
VCCCORE	Regulated voltage	VCC_SEL shorted to GND	3	3.3	3.6	V
		VCC_SEL shorted to VCCCORE	4.5	5	5.5	V
VCC_OK <sub>RIS</sub>	VCC_OK rising threshold	VCC_SEL shorted to GND	2.3	-	2.8	V
		VCC_SEL shorted to VCCCORE	3.3	-	4	V
VCC_OK <sub>FALL</sub>	VCC_OK falling threshold	VCC_SEL shorted to GND	2.0	-	2.5	V

Symbol	Parameter	Conditions	Min.	Typ.	Max.	Unit
VCC_OK <sub>FALL</sub>	VCC_OK falling threshold	VCC_SEL shorted to VCCCORE	2.9	-	3.6	V
VCC_OK <sub>HYST</sub>	VCC_OK hysteresis	VCC_SEL shorted to GND	-	0.3	-	V
		VCC_SEL shorted to VCCCORE	-	0.4	-	V
I <sub>VCCSEL</sub>	VCCSEL internal pull- down current	-	-	6	-	μA
<b>Programmable DC-DC switching converter</b>						
V <sub>IN</sub>	Input voltage at DCDC_IN pin	-	13	-	32	V
V <sub>OUT</sub>	Output voltage adjusting range	-	1	-	12	V
V <sub>FB</sub>	Feedback voltage reference	-	0.9	1	1.1	V
UVLO <sub>RIS</sub>	Undervoltage lockout rising threshold on VIN voltage	V <sub>IN</sub> rising	9	10	11	V
UVLO <sub>FALL</sub>	Undervoltage lockout falling threshold on VIN voltage	V <sub>IN</sub> falling	5.4	6	6.6	V
UVLO <sub>HYST</sub>	Undervoltage lockout hysteresis on VIN voltage	-	-	4	-	V
I <sub>LIM</sub>	High side MOSFET current limit	-	325	650	975	mA
V <sub>OUT_RIP</sub>	Output voltage ripple	13 V < V <sub>IN</sub> < 32 V 3.3 V < V <sub>OUT</sub> < 12 V I <sub>OUT</sub> = 5 mA ~ 150 mA C <sub>OUT</sub> = 22 μF MLCC <sup>(1)</sup>	-	50	-	mV
R <sub>DS(ON)</sub>	High side MOSFET on resistance	-	-	1.9	-	Ω
	Low side MOSFET on resistance	-	-	1.2	-	Ω
OTP	Overtemperature protection	Junction temperature <sup>(2)</sup>	110	140	-	°C
OVP <sub>RIS</sub>	Overvoltage protection rising threshold on FB	FB voltage rising	1.1	1.25	1.4	V
OVP <sub>FALL</sub>	Overvoltage protection falling threshold on FB	FB voltage falling	0.95	1.1	1.25	V
I <sub>SS</sub>	Current sourced from SS pin	During soft-start	-	2.5	-	μA
<b>Transmitter</b>						
R <sub>DS(ON)</sub>	Tx MOSFET on resistance	-	-	5	-	Ω
I <sub>KNX_TX</sub>	KNX_TX internal pull- down current	-	-	6	-	μA
<b>Digital I/Os</b>						
V <sub>IL</sub>	Maximum voltage level that will be interpreted as a logic 0	VCCCORE = 3.3 V	0.7	-	-	V
		VCCCORE = 5 V	1.2	-	-	
V <sub>IH</sub>	Minimum voltage level that will be interpreted as a logic 1	VCCCORE = 3.3 V	-	-	2.2	V
		VCCCORE = 5 V	-	-	3	
V <sub>OL</sub>	Logic low output level	VCCCORE = 3.3 V I <sub>SUNK</sub> = 300 μA	0	-	0.4	V
		VCCCORE = 5 V I <sub>SUNK</sub> = 400 μA	0	-	0.4	V
V <sub>OH</sub>	Logic high output level	VCCCORE = 3.3 V, I <sub>SOURCED</sub> = 300 μA	VCCCORE - 0.5	-	VCCCORE	V

Symbol	Parameter	Conditions	Min.	Typ.	Max.	Unit
$V_{OH}$	Logic high output level	$V_{CC_{CORE}} = 5\text{ V}$ , $I_{SOURCED} = 400\ \mu\text{A}$	$V_{CC_{CORE}} - 0.5$	-	$V_{CC_{CORE}}$	V

1. *Not tested in production. Guaranteed by design.*
2. *Not tested in production. Based on characterization.*

## 5 Device description

The STKNX is a transceiver device for twisted pair communication, following the KNX twisted pair standard (KNX TP1-256). Detailed information on the KNX bus can be found in the KNX standards and on the KNX website ([www.knx.org](http://www.knx.org)).

The STKNX is composed of two main functional blocks: the bus interface and the voltage regulators.

- The bus interface consists of the transmitter, receiver and impedance modulator
- The voltage regulators block consists of an adjustable output voltage step down switching converter with integrated power MOSFETs and a 3.3 V / 5 V programmable linear regulator

**Figure 7. KNX bus voltage and corresponding digital signals**

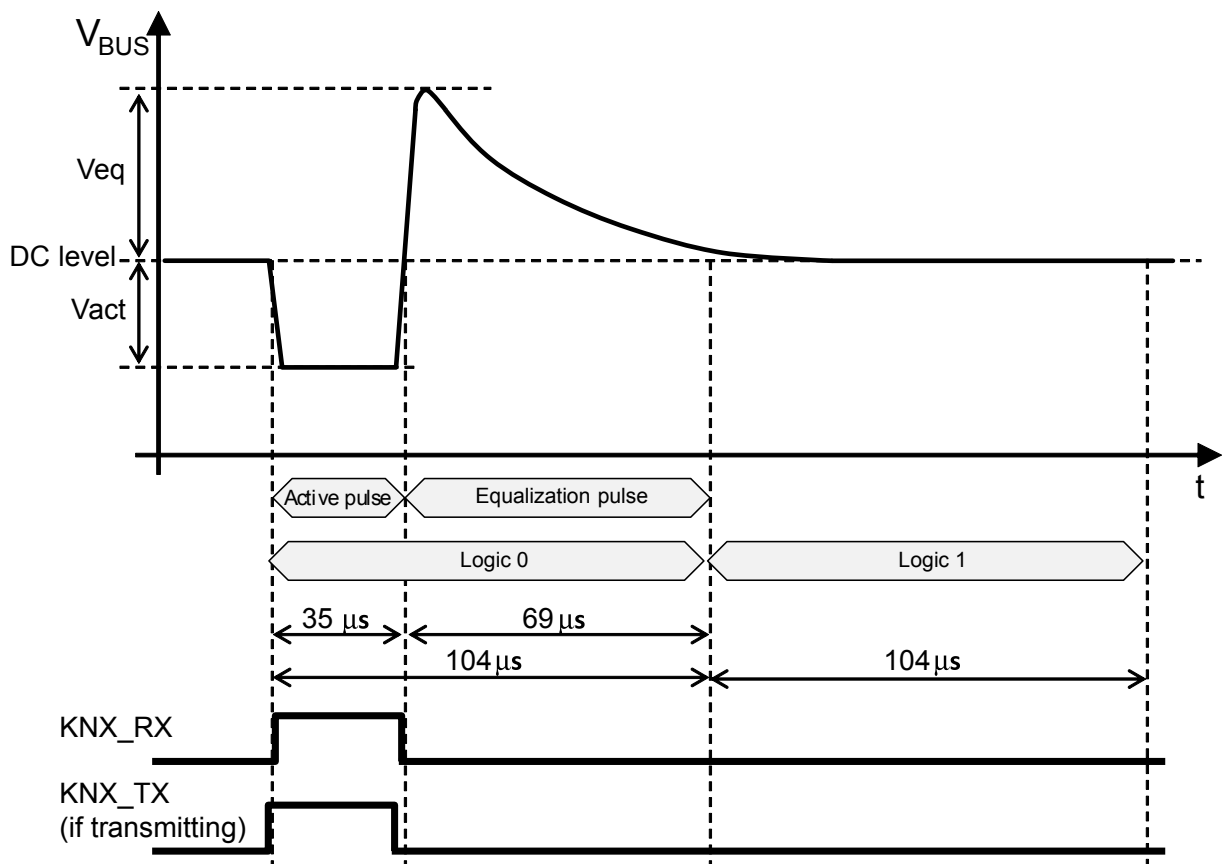

### 5.1 Bus interface

The bus interface connects the STKNX to the KNX bus for transmitting, receiving and extracting power.

Through the bus interface, the STKNX supports

- Interfacing a microcontroller with the KNX bus, translating signals between the logic level domain and KNX bus domain
- Extracting power from the bus to supply the STKNX itself, the microcontroller and application devices

The KNX standard specifies a bit period of  $104 \mu s$ . It defines the logic 1 as the idle state of the bus (DC voltage level between 21 V and 32 V), the logic 0 (also called active pulse) as a voltage drop of the bus.

The active pulse is generated by the transmitter. Ideally, the drop has a rectangular shape, a depth between 6 V and 9 V and a duration of  $35 \mu s$ . Each active pulse is followed by an equalization phase of  $69 \mu s$  typical duration, which consists in an overshoot of the bus voltage above the DC level, followed by an exponential decay.

See the KNX Twisted Pair Standard (KNX TP1-256) for more detailed information.

### 5.1.1 Transmitter

The transmitter converts logic level signals received at the KNX\_TX pin to analog signals on the KNX bus. To transmit a logic 1 (equivalent to transmitter in idle state), the KNX\_TX pin has to be kept low for 104  $\mu$ s. To transmit a logic 0, the KNX\_TX has to be forced high for 35  $\mu$ s (active pulse) and then low for 69  $\mu$ s.

During the active pulse, the transmitter forces a voltage drop of 7.5 V typ. on the KNX bus, by sinking current through the R68 pin.

### 5.1.2 Receiver

The receiver detects the beginning and the end of the active pulse and provides a logic level output on the KNX\_RX pin. The KNX\_RX pin is high during the active pulse, low during the equalization phase and idle state.

The detection threshold for the start of the active pulse is 0.6 V typ. below the bus DC voltage.

### 5.1.3 Impedance modulator

The KNX standard allows a bus voltage ranging from 21 V to 32 V (DC component). The bus provides supply for the STKNX and is the communication medium. During transmission, a -10.5 V / +13 V AC component can be superimposed to the DC component mentioned above.

Moreover, the KNX standard specifies that each module connected to the bus has to show a controlled impedance and to limit the bus load current slope  $di/dt$ , while not transmitting.

The impedance modulator purpose is to extract power from the KNX bus in order to supply STKNX integrated voltage converters and the application on the KNX module, while ensuring compliance to KNX impedance specifications.

In particular, impedance modulator:

- Extracts a stable power rail (VDDHV) from the KNX bus DC level
- Smooths any load change applied at its output, limiting  $di/dt$  on the bus current
- Controls the impedance of the bus device during the active pulse and the equalization pulse according to KNX standard requirements

Since the current drawn from the bus must change very slowly, abrupt load current steps from the load applied to the STKNX have to be absorbed by the large filter capacitor on VDDHV rail (CVDDHV on [Figure 1](#)), which should be sized accordingly.

The bus current slope limit is controlled through CGATE ([Figure 1](#)).

CGATE = 47  $\mu$ F sets a slope lower than 0.5 mA/ms, compliant to the KNX requirement for fan in model up to the 10 mA bus load.

For a higher fan in, it can be useful to set a higher current slope limit, in order to manage wider load changes minimizing the CVDDHV value. That can be done by reducing the CGATE value proportionally to the desired slope limit increase.

[Table 7](#) shows recommended CGATE and CVDDHV values for the minimum and maximum fan in.

**Table 7. Recommended CGATE and CVDDHV vs. fan-in**

Fan in	Recommended CGATE	Recommended minimum CVDDHV
10 mA	47 $\mu$ F	100 $\mu$ F
30 mA	10 $\mu$ F - 47 $\mu$ F	220 $\mu$ F

## 5.2 Voltage regulators

The STKNX features two integrated voltage regulators for external use in the application:

- a linear regulator with 3.3 V or 5 V selectable output voltage, 20 mA current capability
- a step down switching converter with 1 V - 12 V adjustable output voltage, 150 mA current capability.

### 5.2.1 3.3 V / 5 V linear regulator

The linear regulator converts the input voltage on the VDD\_REGIN pin to 3.3 V or 5 V output on the VCCCORE pin. The output voltage level is selectable by the VCCSEL pin.

- VCCSEL tied to GND  $\rightarrow$  VCCCORE = 3.3 V
- VCCSEL tied to VCCCORE  $\rightarrow$  VCCCORE = 5 V



VCCSEL should not be changed when STKNX is operational.

The output current capability is 20 mA. A 4.7  $\mu\text{F}$  capacitor or higher is required between VCCCORE and KNX\_B for stability.

VCCCORE is also the supply input for STKNX digital I/Os. The linear regulator can be disabled by shorting VCCCORE to VDD\_REGIN; in that case VCCCORE voltage to supply I/Os has to be provided externally and VCCSEL has to be configured according to the voltage level (3.3 V or 5 V).

### 5.2.2 Buck converter

The STKNX integrates a high-efficiency low-consumption buck switching converter.

The switching converter is supplied from the DCDC\_IN pin, connected to VDDHV rail in the typical application. When voltage at the DCDC\_IN pin is lower than UVLO, the switching converter is disabled.

Buck converter output voltage is adjustable between 1 V and 12 V by means of an external resistor divider on the DCDC\_FB pin, according to the following expression:

$$V_{OUT} = 1V \cdot \left( \frac{1 + RFB1}{RFB2} \right) \quad (1)$$

Where RFB1 and RFB2 are the upper and lower resistor of the divider respectively (see Figure 1). The RFB2 typical value is 10 k $\Omega$  (RFB2 values higher than 100 k $\Omega$  should be avoided).

To set  $V_{OUT} = 1$  V, RFB1 should be 0  $\Omega$  and RFB2 not mounted.

In the usual case of the low ESR ceramic capacitor as the output capacitor for the converter, it is recommended to add an external feedforward compensation capacitor CFB1 in parallel to RFB1, for  $V_{OUT} > 1$  V.

The CFB1 default value can be calculated according to the following expression:

$$CFB1 = \frac{1}{2\pi \cdot RFB1 \cdot 28kHz} \quad (2)$$

The buck converter can deliver a continuous output current up to 150 mA, however the maximum current capability will not always be usable. In fact, at the application level, the KNX bus current consumption must stay within the KNX specification.

The buck converter implements soft-start to prevent a high inrush current at start-up. Soft-start time  $T_{SS}$  is programmable through the external capacitor  $C_{SS}$  between the DCDC\_SS pin and GND, according to the following expression:

$$T_{SS} = 1V \cdot \frac{C_{SS}}{I_{SS}} \quad (3)$$

where  $I_{SS}$  is 2.5  $\mu\text{A}$  typ.

The buck converter features a full set of protections, which includes overtemperature protection (OTP), overcurrent protection (OCP) and overvoltage protection (OVP).

## 6 Layout recommendations

PCB layout is an important part of DC-DC switching converter design. A poor board layout can compromise important parameters of the DC-DC converter such as efficiency, output voltage ripple, line and load regulation and stability.

Good layout for the STKNX can be implemented by following the few simple design rules listed in this section. These rules have been applied to the STKNX routed area on the STKNX evaluation board (EVALKITSTKNX), where only the TOP and BOTTOM layers have been used from the four available, so it can be transposed on a low cost 2-layer PCB. It is then easy to implement the rules on a final KNX product. The source files of EVALKITSTKNX PCB layout are available for download from [www.st.com](http://www.st.com).

**Figure 8. STKNX area routed using top and bottom layers only**

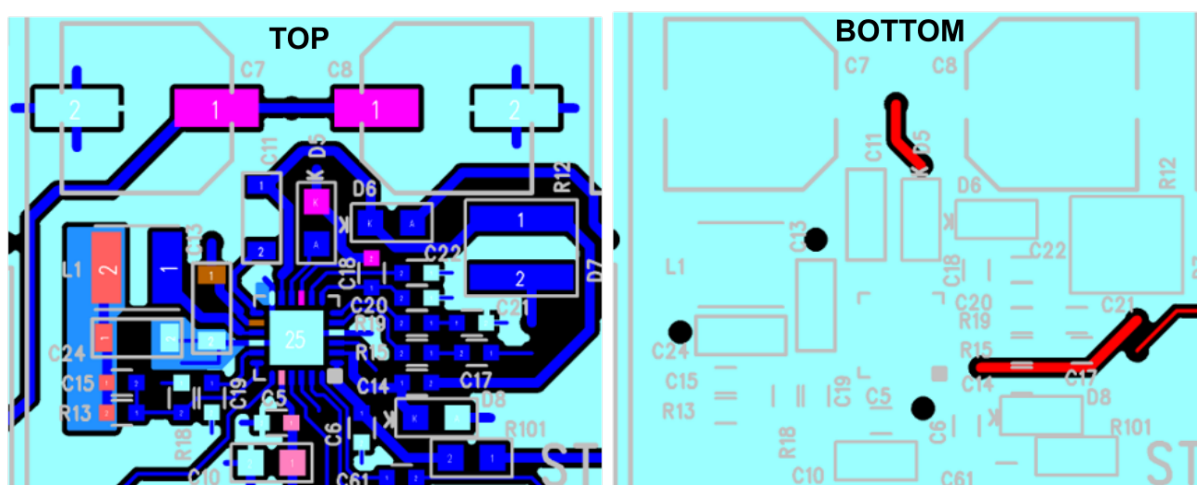

Refer to Figure 9 and Figure 10 below for the recommendations described below:

- Place CIN (C13) close to the STKNX and connect it between pins VIN and DCDC\_GND directly on top layer (DCDC\_LX trace crosses between CIN pads)
- Connect COUT (C24) to DCDC\_GND directly on top layer
- Keep the following power loops short:
  - CIN → DCDC\_IN → DCDC\_LX → L1 → COUT → CIN (green)
  - COUT → DCDC\_GND → DCDC\_LX → L1 → COUT (red)
  - CIN → DCDC\_IN → DCDC\_GND → CIN (purple)
- Use properly sized traces or shapes for power paths (DCDC\_IN, DCDC\_GND, VDCDC, LX)
  - Keep FB/Feedback and SS/Soft-Start components (Rfbx, Cfb1, Css) away from switching / noisy node (DCDC\_LX), shielding with quiet nets (DCDC\_GND in the image) is recommended (black)
  - Connect DCDC\_GND pin (16) and KNX\_B pins (4 and 12) to the exposed pad shape below the IC, as shown in Figure 10, to ensure ground consistency
  - Place several GND vias on STKNX package exposed pad (x9 in EVALKITSTKNX).

Figure 9. Layout recommendations description

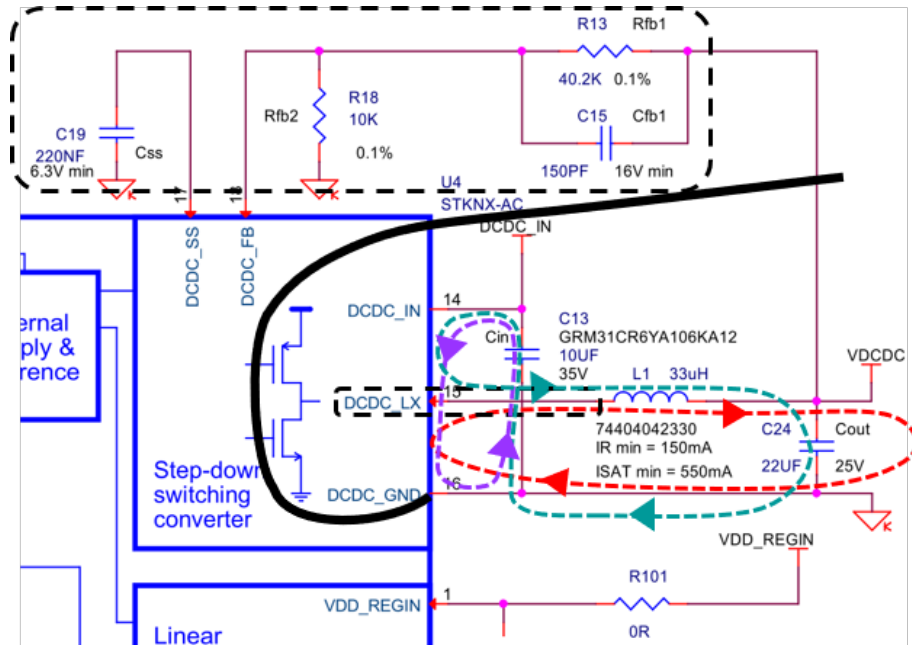
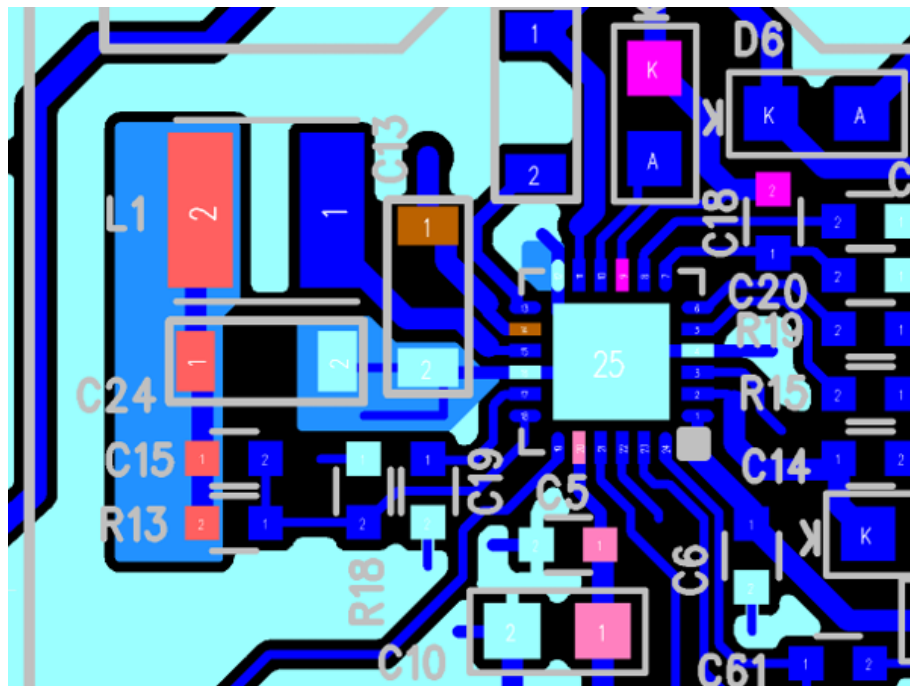

Figure 10. Layout recommendations application



## 7 Package information

In order to meet environmental requirements, ST offers these devices in different grades of **ECOPACK** packages, depending on their level of environmental compliance. ECOPACK specifications, grade definitions and product status are available at: [www.st.com](http://www.st.com). ECOPACK is an ST trademark.

### 7.1 VFQFPN 4 x 4 x 1.0 24 pitch 0.5 package information

Figure 11. VFQFPN 4 x 4 x 1.0 24 pitch 0.5 package outline

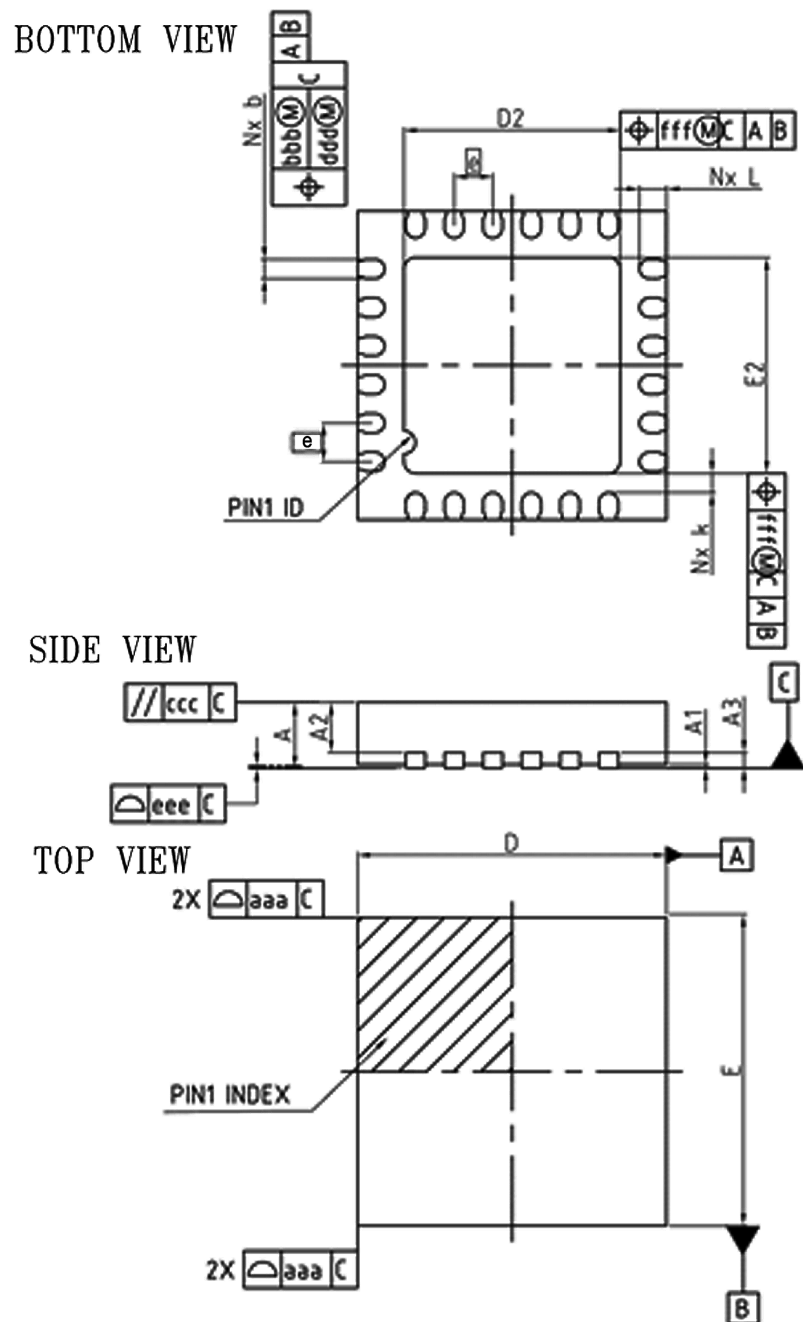

**Table 8. VFQFPN 4 x 4 x 1.0 24 pitch 0.5 package mechanical data**

Symbol	Dimensions [mm]		
	Min.	Nom.	Max.
A	0.80	-	1.00
A1	0.00	-	0.05
A2	-	0.65	-
A3	-	0.20	-
b	0.20	0.25	0.30
D	3.9	4.0	4.1
D2	2.7	2.8	2.9
e	-	0.5	-
E	3.9	4.0	4.1
E2	2.7	2.8	2.9
L	0.30	0.35	0.40
k	0.20	-	-
N	-	24	-
Symbol	Tolerance of form and position [mm]		
aaa	0.15		
bbb	0.10		
ccc	0.10		
ddd	0.05		
eee	0.08		
fff	0.10		

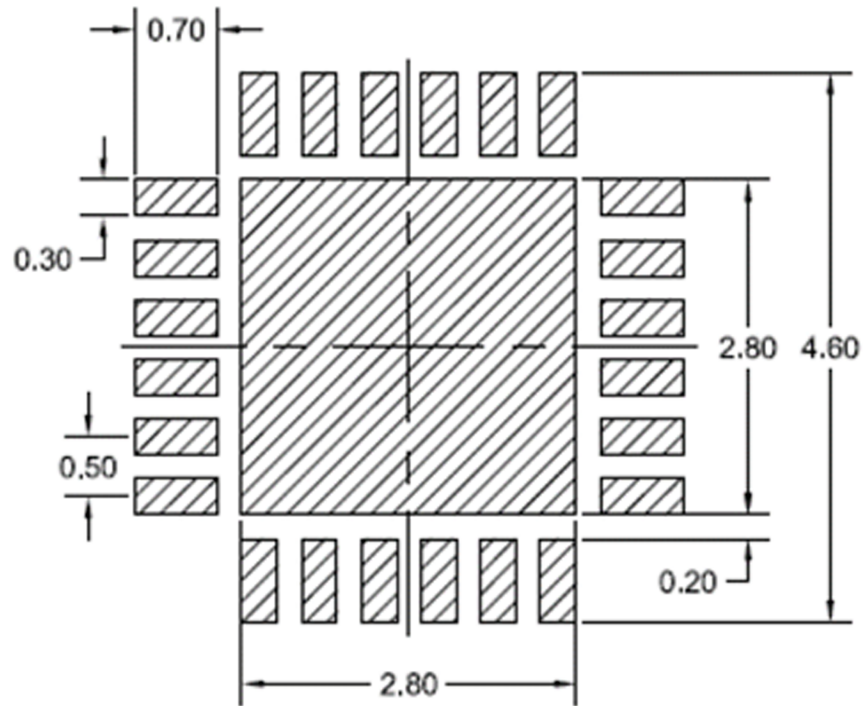
**Figure 12. Suggested footprint**

## Revision history

**Table 9. Document revision history**

Date	Version	Changes
08-Feb-2018	1	Initial release.
06-Dec-2020	2	Throughout document: - layout and template changes - minor text edits Added <a href="#">Section 6</a> <a href="#">Layout recommendations</a>

## Contents

<b>1</b>	<b>Typical application circuit and block diagram</b>	<b>2</b>
1.1	Typical application circuit	2
1.2	Block diagram	7
<b>2</b>	<b>Pin connection and pin description</b>	<b>8</b>
2.1	Pin connection	8
2.2	Pin description	8
<b>3</b>	<b>Thermal characteristics</b>	<b>10</b>
<b>4</b>	<b>Electrical specifications</b>	<b>11</b>
4.1	Absolute maximum ratings	11
4.2	Recommended operating conditions	11
4.3	Electrical characteristics	12
<b>5</b>	<b>Device description</b>	<b>15</b>
5.1	Bus interface	15
5.1.1	Transmitter	16
5.1.2	Receiver	16
5.1.3	Impedance modulator	16
5.2	Voltage regulators	16
5.2.1	3.3 V / 5 V linear regulator	16
5.2.2	Buck converter	17
<b>6</b>	<b>Layout recommendations</b>	<b>18</b>
<b>7</b>	<b>Package information</b>	<b>20</b>
7.1	VFQFPN 4 x 4 x 1.0 24 pitch 0.5 package information	20
	<b>Revision history</b>	<b>23</b>



## List of figures

<b>Figure 1.</b>	Typical application circuit, buck converter enabled, linear regulator supplied by impedance modulator . . . . .	2
<b>Figure 2.</b>	Typical application circuit, buck converter enabled, linear regulator supplied by buck converter . . . . .	3
<b>Figure 3.</b>	Typical application circuit, buck converter disabled . . . . .	4
<b>Figure 4.</b>	Typical application circuit, linear regulator disabled . . . . .	5
<b>Figure 5.</b>	STKNX Block diagram . . . . .	7
<b>Figure 6.</b>	Pin connection (top view) . . . . .	8
<b>Figure 7.</b>	KNX bus voltage and corresponding digital signals . . . . .	15
<b>Figure 8.</b>	STKNX area routed using top and bottom layers only . . . . .	18
<b>Figure 9.</b>	Layout recommendations description. . . . .	19
<b>Figure 10.</b>	Layout recommendations application. . . . .	19
<b>Figure 11.</b>	VFQFPN 4 x 4 x 1.0 24 pitch 0.5 package outline . . . . .	20
<b>Figure 12.</b>	Suggested footprint. . . . .	22

## List of tables

<b>Table 1.</b>	External components typical value . . . . .	5
<b>Table 2.</b>	STKNX Pin description . . . . .	8
<b>Table 3.</b>	Thermal characteristics. . . . .	10
<b>Table 4.</b>	Absolute maximum ratings . . . . .	11
<b>Table 5.</b>	Recommended operating conditions. . . . .	11
<b>Table 6.</b>	Electrical characteristics . . . . .	12
<b>Table 7.</b>	Recommended CGATE and CVDDHV vs. fan-in . . . . .	16
<b>Table 8.</b>	VFQFPN 4 x 4 x 1.0 24 pitch 0.5 package mechanical data . . . . .	21
<b>Table 9.</b>	Document revision history . . . . .	23