

Step-up controller for LED supply

Features

- Input voltage range from 0.8 V to 3.6 V
- Overvoltage protection
- Drives N-channel MOSFET or NPN bipolar transistor
- No control loop compensation required
- FET driver for very precise PWM dimming

Applications

- Single/dual cell NiMH, NiCd, or alkaline batteries
- Small appliances LED lighting
- Portable lighting

Description

The STLDC08 LED driver step-up controller is optimized to operate from one or two NiCd/NiMH or alkaline cells. The IC is able to drive an external MOSFET (N-channel) enabling it for use with wide power levels. Hysteretic control eliminates the need for small signal control loop compensation. The IC integrates an FET driver for a precise PWM dimming. STLDC08 comes in a DFN10 (3 x 3 mm) package.

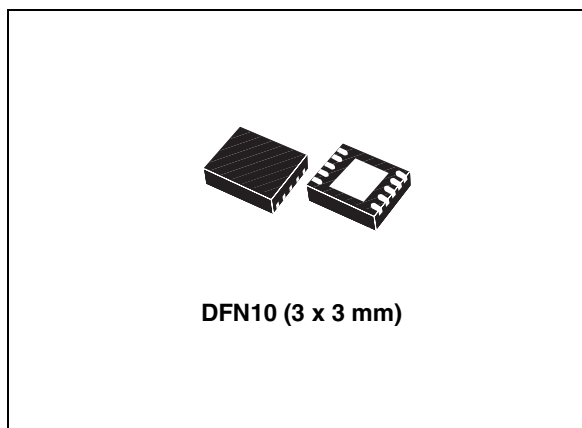

Table 1. Device summary

Order code	Marking	Package
STLDC08PUR	STLDC08	DFN10 (3 x 3 mm.)

Contents

- 1 Application diagram 3**
- 2 Absolute maximum ratings 5**
- 3 Pin configuration 6**
- 4 Electrical characteristics 7**
- 5 Typical performance characteristics 9**
- 6 Block diagram 11**
- 7 Detailed description 12**
 - 7.1 Main control loop 12
 - 7.2 Start up 12
 - 7.3 Over voltage protection (OVP) 13
 - 7.4 Enable/PWM 13
 - 7.5 Dimming 14
- 8 Application information 15**
 - 8.1 LED current programming 15
 - 8.2 Duty cycle 15
 - 8.3 Inductor selection 15
 - 8.4 Inductor peak current limit 17
 - 8.5 Power MOSFET selection 18
 - 8.6 Schottky diode selection 20
 - 8.7 Input capacitor 20
 - 8.8 Output capacitor 20
- 9 Demonstration board 21**
- 10 Layout suggestion 22**
- 11 Package mechanical data 24**

12 **Revision history** **28**

1 Application diagram

Figure 1. Electric schematic optimized for 2 LEDs and $I_{LED} = 200\text{ mA}$

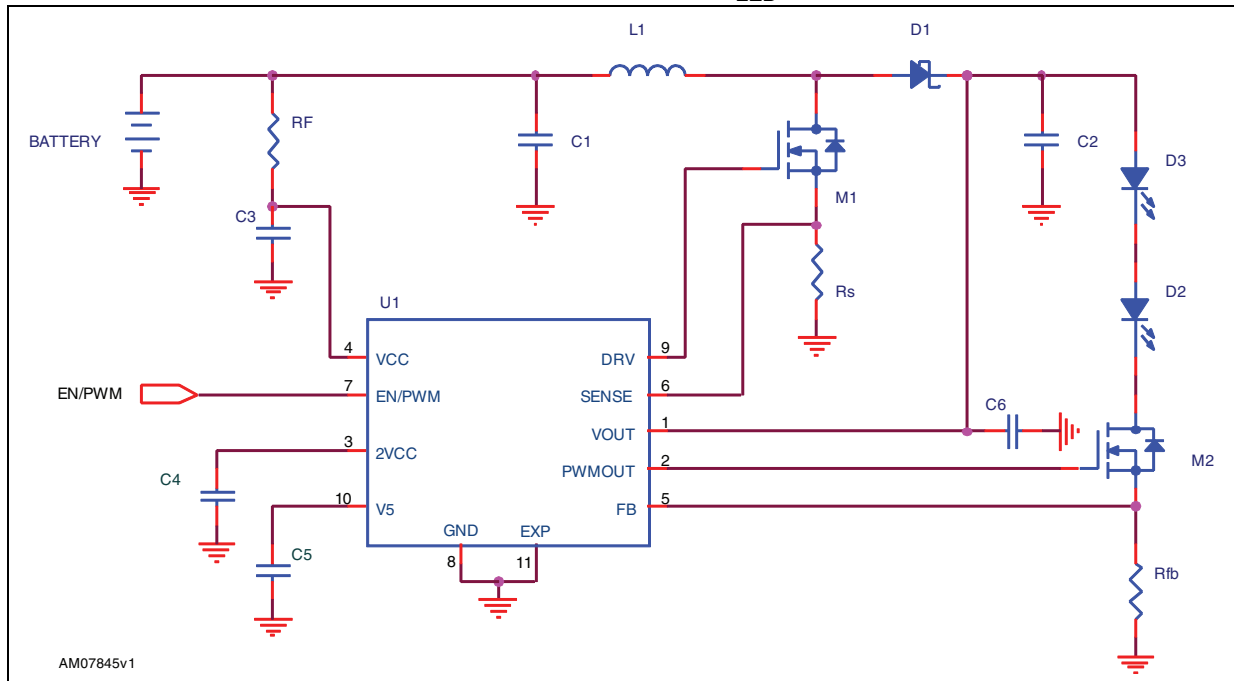

Table 2. List of components

Reference	Manufacturer	Part number	Value	Size
C1	Murata	GRM21BR60J475	4.7 μF , 6.3 V	0805
C2	Murata	GRM31CB31C106K	10 μF , 16 V	1206
C4	Murata	GRM188R70J103KA01B	10 nF, 6.3 V	0603
C3, C5, C6	Murata	GRM188R61C105K	1 μF , 16 V	0603
L	Coilcraft	LPS6235-103ML	10 μH	6 mm x 6 mm
M1,M2	STMicroelectronics	STS5DNF20V		SO-8
D1	STMicroelectronics	STPS2L30		SMA
Rfb			0.47 Ω	0805
Rs			0.047 Ω	0805
RF			0 Ω	0603

Figure 2. Electric schematic optimized for 4 LEDs and $I_{LED} = 300\text{ mA}$

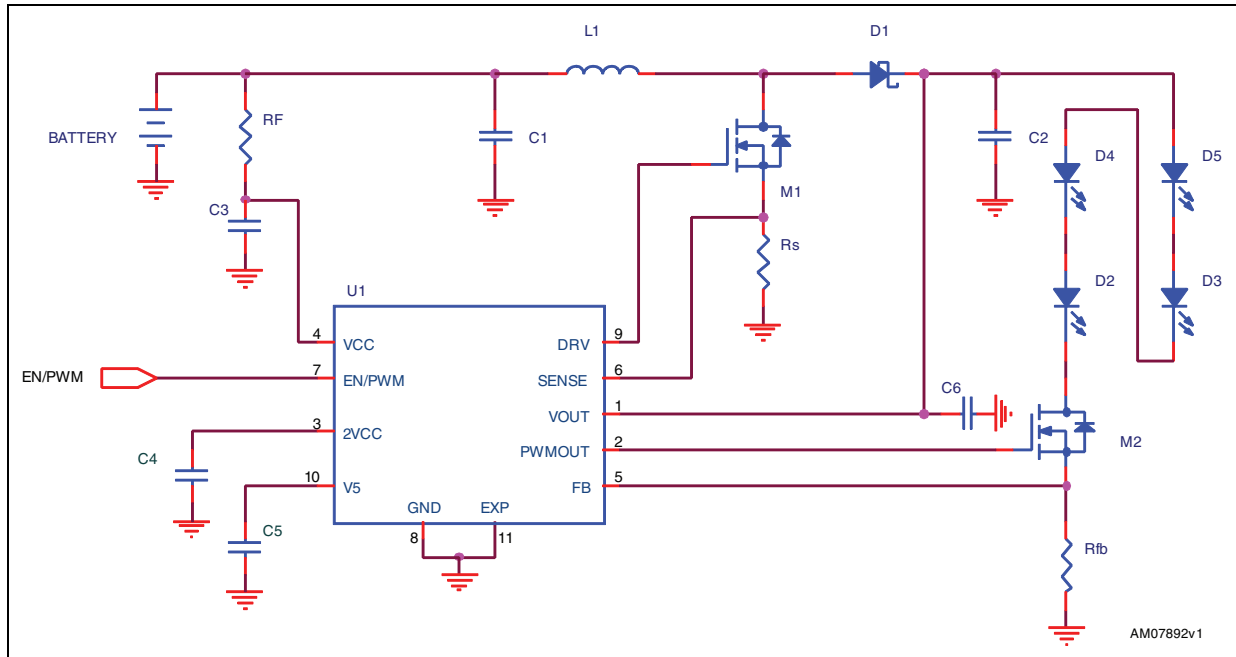

Table 3. List of components

Part reference	Manufacturer	Part number	Value	Size
C1	Murata	GRM21BR60J106KE19	10 μF , 6.3 V	0805
C2	Murata	GRM31CR61C226K	22 μF , 16 V	1206
C4	Murata	GRM188R70J103KA01B	10 nF, 6.3 V	0603
C3, C5, C6	Murata	GRM188R61C105K	1 μF , 16 V	0603
M1,M2	STMicroelectronics	STS5DNF20V		SO-8
D1	STMicroelectronics	STPS2L30		SMA
L	Coilcraft	DO3316P-223_L	22 μH	12.95 mm x 9.4 mm
Rfb			0.33 Ω	0805
Rs			0.033 Ω	0805
RF			0 Ω	0603

2 Absolute maximum ratings

Table 4. Absolute maximum ratings

Symbol	Parameter	Value	Unit
V_{CC}	Supply voltage	- 0.3 to 4.6	V
EN/PWM	Analog input	- 0.3 to 7	V
FB	Analog input	- 0.3 to 2	V
SENSE	Analog input	- 0.3 to 20	V
$2V_{CC}$	Analog outputs	0 to 4	V
V5	Analog outputs	- 0.3 to 7	V
DRV, PWMOUT	Analog outputs	$V_{CC} - 1.2$ to 7	V
V_{OUT}	Output voltage	- 0.3 to 20	V
ESD	Human body model (all pins)	± 2	kV
P_D	DFN10L 3x3 $T_A = 25\text{ }^\circ\text{C}$	2.2	W
T_J	Junction temperature	- 40 to 85	$^\circ\text{C}$
T_{STG}	Storage temperature range	- 55 to 85	$^\circ\text{C}$

Note: Absolute maximum ratings are those values beyond which damage to the device may occur. Functional operation under these conditions is not implied.

Table 5. Thermal data

Symbol	Parameter	Value	Unit
R_{thJC}	Thermal resistance junction-case	3	$^\circ\text{C}/\text{W}$
R_{thJA}	Thermal resistance junction-ambient	57.1 ⁽¹⁾	$^\circ\text{C}/\text{W}$

1. With two sides, two planes PCB following EIA/JEDEC JESD51-7 standard.

3 Pin configuration

Figure 3. Pin connections (top through view)

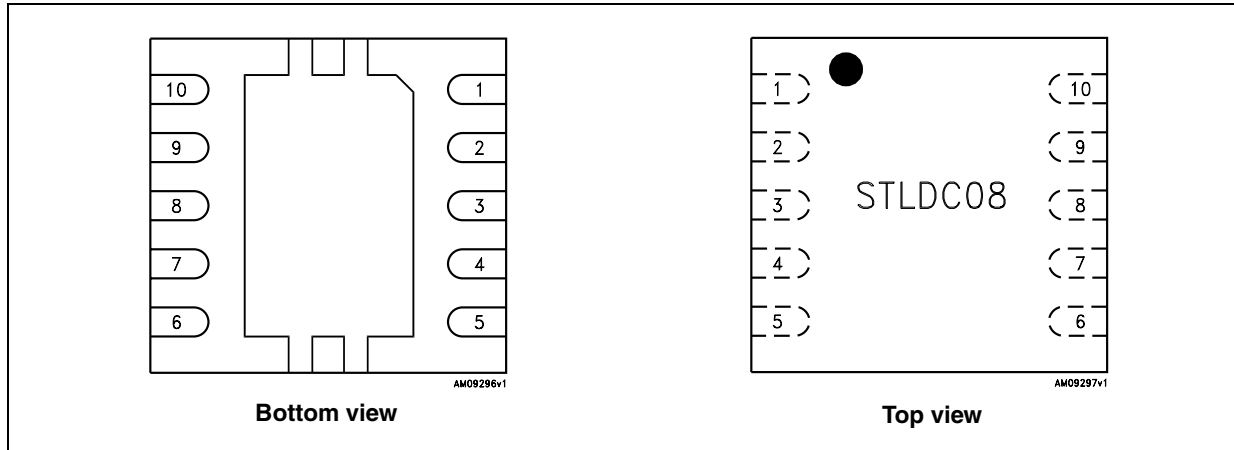

Table 6. Pin description

Pin #	Pin name	Pin function
1	VOUT	Over voltage protection and supply pin for the IC when $V_{OUT} > 2\text{ V}$
2	PWMOUT	Driver of the external MOSFET for PWM dimming. The driver stage is controlled by EN/PWM signal
3	2Vcc	Charge pump output
4	VCC	Supply voltage when $V_{OUT} < 2\text{ V}$, this pin represents the input of the internal charge pump
5	FB	Feedback pin for LED current control
6	SENSE	Sense resistor for current mode control and peak current limit
7	EN/PWM	Enable pin and PWM control input for PWMOUT pin
8	GND	Ground reference
9	DRV	Driver output for Boost stage MOSFET
10	V5	Internal regulator output. Decouple this pin locally to the IC ground with a minimum of $1\ \mu\text{F}$ ceramic capacitor
	Exposed Pad	The exposed pad needs to be connected and soldered to analog ground

4 Electrical characteristics

$T_A = -40$ to 85 ; $C_{IN} = 22 \mu\text{F}$; $C_{OUT} = 10 \mu\text{F}$; $\text{PWMOUT} = 3300 \text{ pF}$; $\text{DVR} = 3300 \text{ pF}$; $2V_{CC} = 10 \text{ nF}$; $V_5 = 1 \mu\text{F}$; $V_{CC} = 1.5\text{V}$; $V_{OUT} = 3 \text{ V}$; $\text{FB} = \text{GND}$; $\text{SENSE} = \text{GND}$; $\text{EN/PWM} = V_{CC}$; unless otherwise specified.

Table 7. Electrical characteristics

Symbol	Parameter	Test conditions	Min.	Typ.	Max.	Unit
General section						
V_{CC}	Supply voltage range	$V_{OUT} = \text{GND}$	0.8		3.6	V
I_{VCC}	Supply current measured on V_{CC} pin with charge pump ON	$V_{OUT} = \text{GND}$		3		mA
	Shutdown current	EN = GND Shutdown mode		5	10	μA
OVP	Overvoltage protection	Rising edge	18		19.5	V
I_{VOUT}	Operating supply current measured on V_{OUT} pin	$V_{OUT} = 3 \text{ V}$, FB = 500 mV (no switching)		60	100	μA
		$V_{OUT} = 3 \text{ V}$, FB = GND (switching)		800		μA
		$V_{OUT} = 10 \text{ V}$, FB = GND (switching)		1.3	2	mA
	Shutdown current	EN = GND		5	10	μA
2VCC	Charge pump ON	V_{OUT} floating; $V_{CC} = 0.8 \text{ V}$		1.5		V
Driver section (DRV output)						
V_{DRVL}	Low level voltage	$I_{DRV} = 100 \text{ mA}$		80	160	mV
V_{DRVH}	High level voltage	$I_{DRV} = -100 \text{ mA}$		120	240	mV
t_R	Rise time	$C_{DRV} = 3300 \text{ pF}$		30		ns
t_F	Fall time	$C_{DRV} = 3300 \text{ pF}$		20		ns
FB						
V_{FB}	Feedback voltage	$T_A = 25 \text{ }^\circ\text{C}$	90	105	116	mV
I_{FB}	Bias current	FB = 2 V		20	500	nA
Timing						
$T_{OFF(MIN)}$	Minimum Off time			1		μs
$T_{ON(MAX)}$	Maximum On time			20		μs
PWM OUT section						
$V_{PWMOUTL}$	Low level voltage	$I_{PWMOUT} = 100 \text{ mA}$		200	400	mV
$V_{PWMOUTH}$	High level voltage	$I_{PWMOUT} = -100 \text{ mA}$		250	500	mV
t_r	Rise time	$C_{PWMOUT} = 3300 \text{ pF}$		30		ns
t_f	Fall time	$C_{PWMOUT} = 3300 \text{ pF}$		20		ns

Table 7. Electrical characteristics (continued)

Symbol	Parameter	Test conditions	Min.	Typ.	Max.	Unit
SENSE						
$V_{SENSE\ MAX}$	Maximum current sense threshold		70	100	130	mV
I_{SENSE}	Bias current	$V_{SENSE} = 20\ V$		10	20	μA
EN/PWM section						
V_{IL}	Low level threshold	$V_{CC} = 0.8\ V$			0.3	V
V_{IL}	Low level threshold	$V_{CC} = 3.6\ V$			0.4	V
V_{IH}	High level threshold	$V_{CC} = 0.8\ V$	0.8			V
V_{IH}	High level threshold	$V_{CC} = 3.6\ V$	1.2			V
$I_{EN/PWM}$	EN/PWM pin current	EN/PWM = 3.6 V		2		μA
$I_{EN/PWM}$	EN/PWM pin current	EN/PWM = 5 V		5		μA
+ 5 V regulator						
V5	Output voltage	$V_{OUT} = 6\ V; I_5 = 10\ mA$	4.8	5	5.2	V
$\Delta V_5/\Delta V_{OUT}$	Line regulation	$6\ V < V_{OUT} < 18\ V; I_5 = 10\ mA$		0.02		%/V
ΔV_5	Load regulation	$0 < I_5 < 10\ mA; V_{OUT} = 18\ V$	0.02	0.01		%/mA
$V_{DROPOUT}$	Dropout voltage	$I_5 = 10\ mA$		20		mV
I_{CC}	Short circuit current	$V_{OUT} = 18\ V; V_5 = 0\ V$		140		mA

5 Typical performance characteristics

Figure 4. V_{FB} vs. temperature

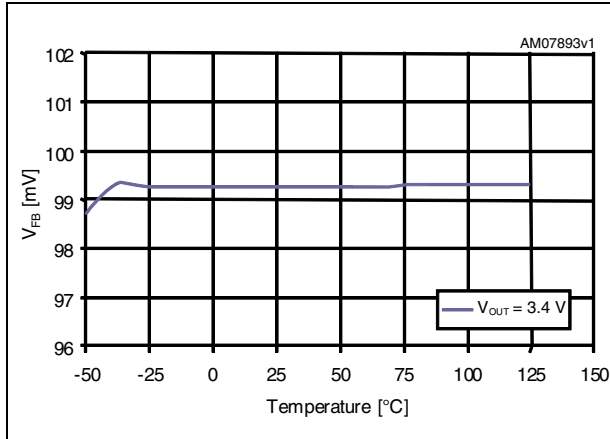

Figure 5. Maximum V_{SENSE} vs. temperature

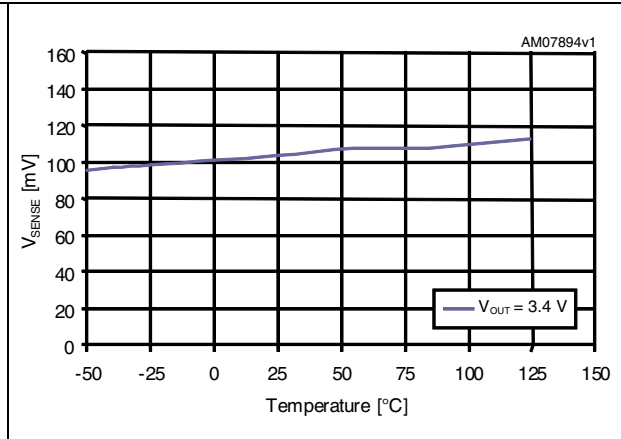

Figure 6. I_{OUT} vs. temperature FB = 0.5 V

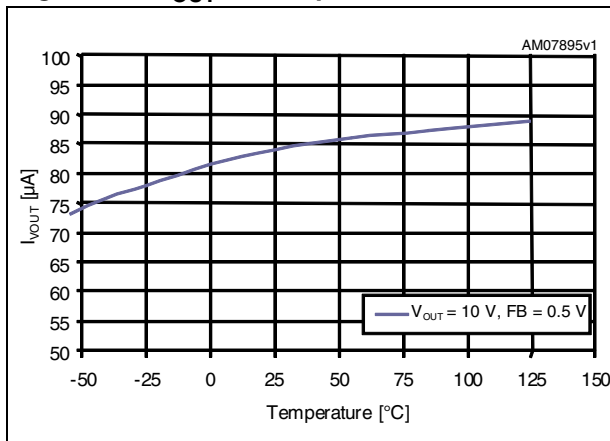

Figure 7. I_{OUT} vs. temperature FB = GND

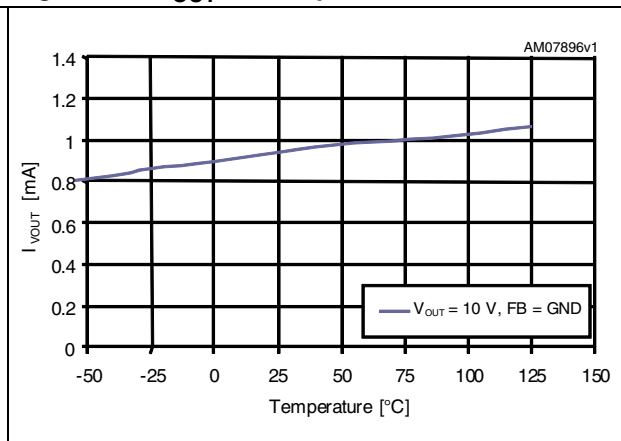

Figure 8. Efficiency vs. input voltage 2 LEDs

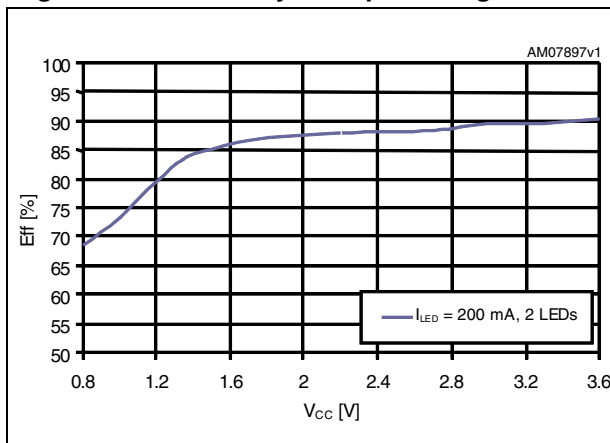

Figure 9. Efficiency vs. input voltage 4 LEDs

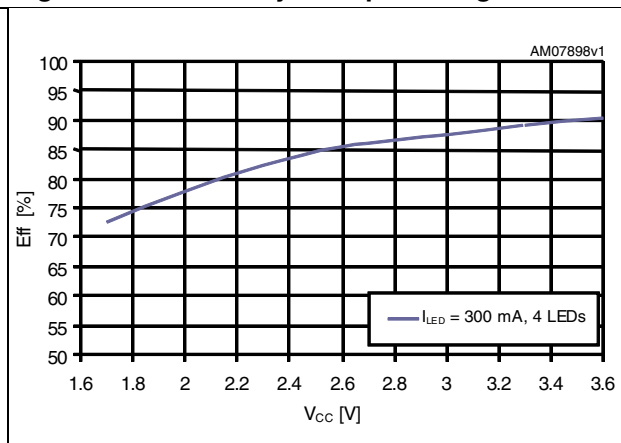

Figure 10. Startup timing and dimming I_{LED} vs. time, 2 LEDs

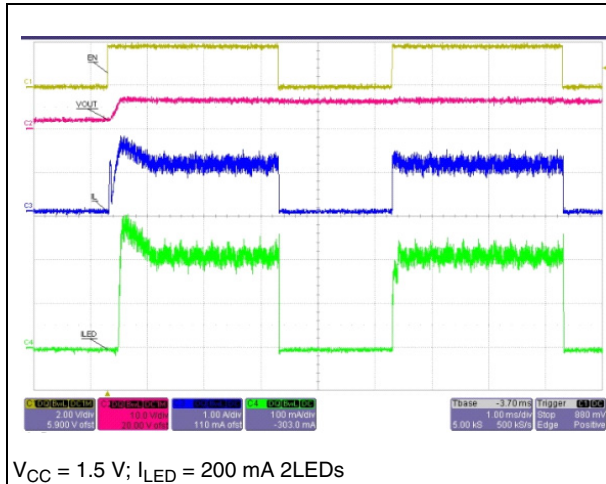

Figure 11. Dimming EN/PWM = 200 Hz, 2 LEDs

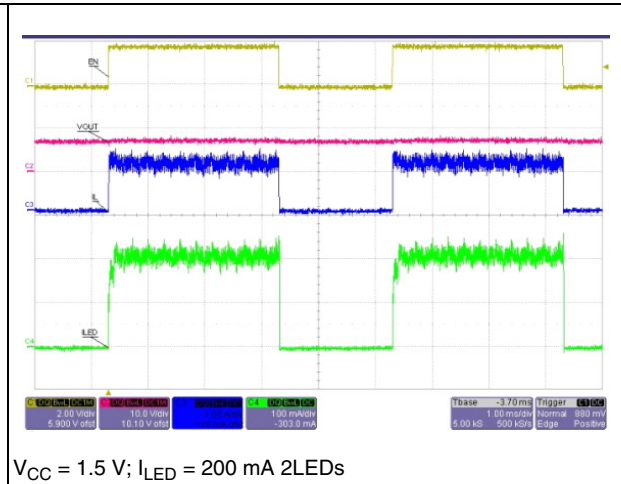

Figure 12. Startup timing and dimming I_{LED} vs. time, 4 LEDs

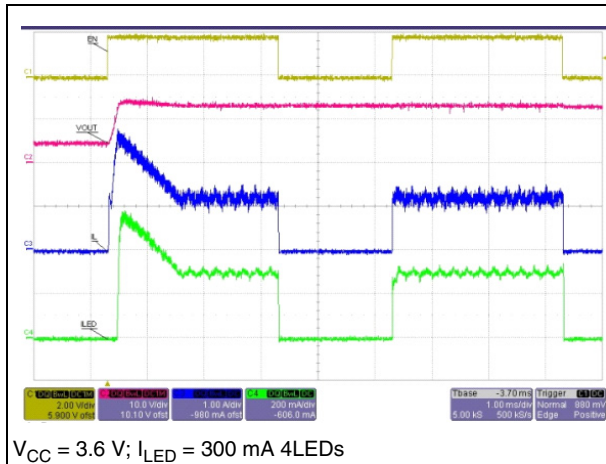

Figure 13. Dimming EN/PWM = 200 Hz, 4 LEDs

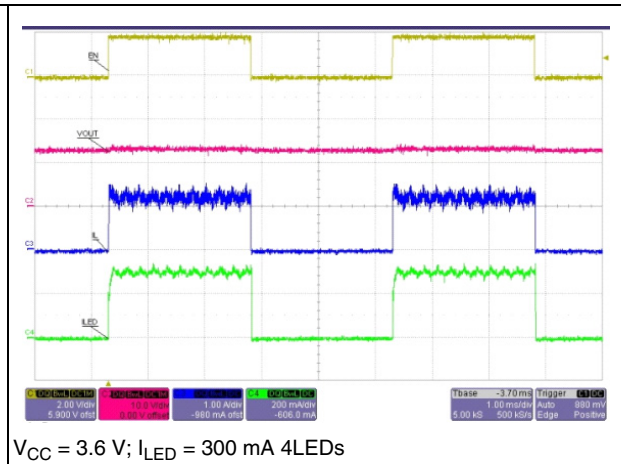

Figure 14. $V_{CC} = 1.5\text{ V}; I_{LED} = 200\text{ mA}$, 2LEDs

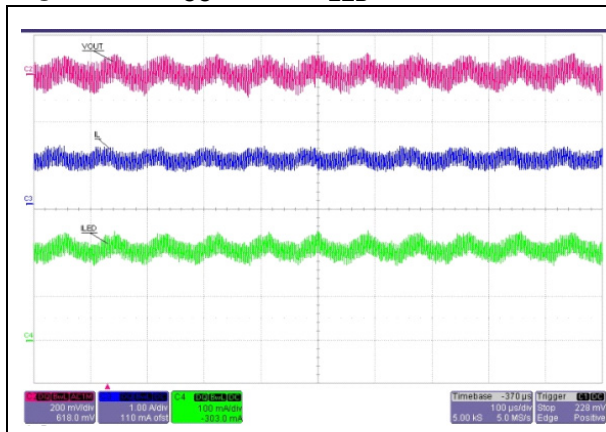
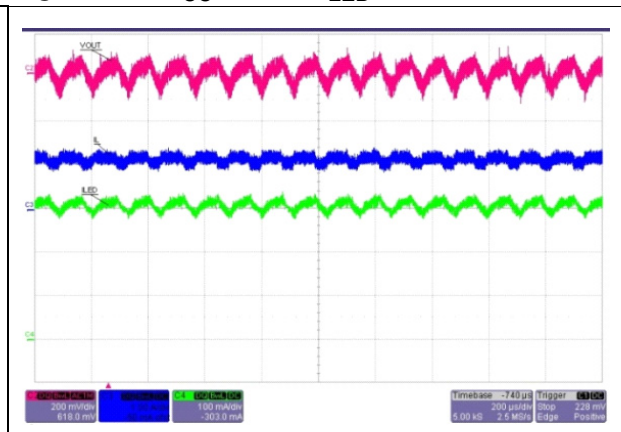
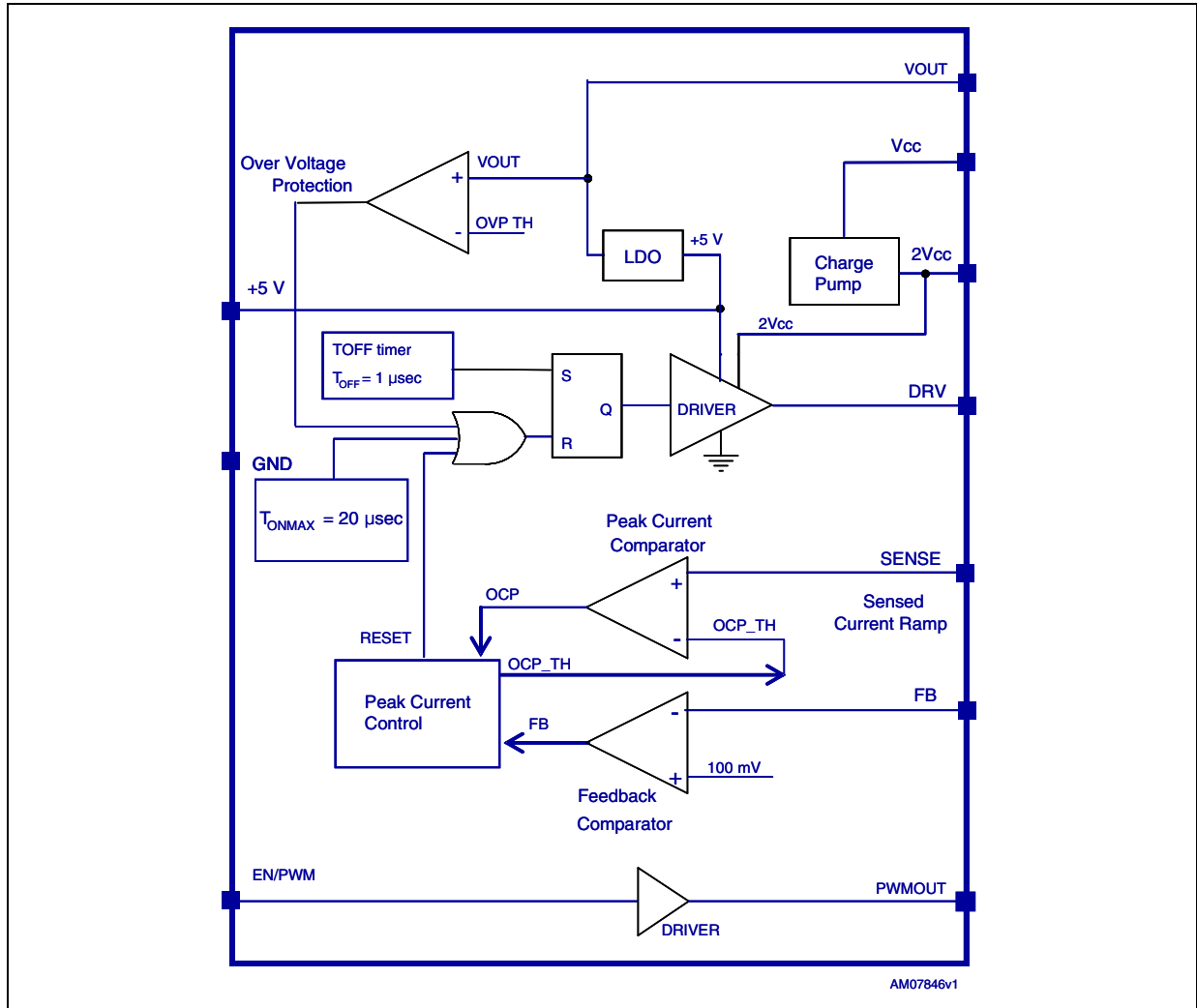

Figure 15. $V_{CC} = 3.6\text{ V}; I_{LED} = 300\text{ mA}$, 4LEDs



6 Block diagram

Figure 16. Block diagram



7 Detailed description

7.1 Main control loop

The STLDC08 is an LED driver step-up controller dedicated to handheld equipment, having a typical voltage ranging from 0.8 V to 1.5 V. The controller drives an N-channel Power MOSFET and implements a hysteretic current mode control with constant OFF time. Hysteretic operation eliminates the need for small signal control loop compensation. The control loop adapts the value of the inductor peak current as needed to deliver the desired current on the LED branch. The LED current is set by an external sense resistor R_{FB} inserted between the feedback pin (FB) and GND. When the current mode control system operates in continuous mode the control peak current is almost equivalent to the average current control.

7.2 Start up

At the startup phase, when the device is connected to the battery or when the EN pin is pulled high, the internal 2x charge pump starts to work, boosting the voltage on the $2V_{CC}$ pin. When the $2V_{CC}$ pin reaches 1.7 V a soft-start cycle begins. The external main MOSFET is switched on/off allowing the charging of the output capacitor.

If the optional PWMOUT MOSFET is used for the dimming operation, the PWMOUT pin is held low, further assuring that no current is flowing. The PWMOUT pin starts to follow the PWM input when the soft-start cycle is ended.

When V_{OUT} voltage exceeds 1.9 V, the chip starts drawing its supply current from V_{OUT} rather than from V_{CC} , the charge pump is turned off and the voltage on the $2V_{CC}$ pin goes to zero. When V_{OUT} exceeds the forward voltage of LED V_{LED} , the current starts flowing through the LED, but, at this point, the voltage on the DRV pin is high enough to allow the main MOSFET to carry the necessary current.

Figure 17. Timing diagram

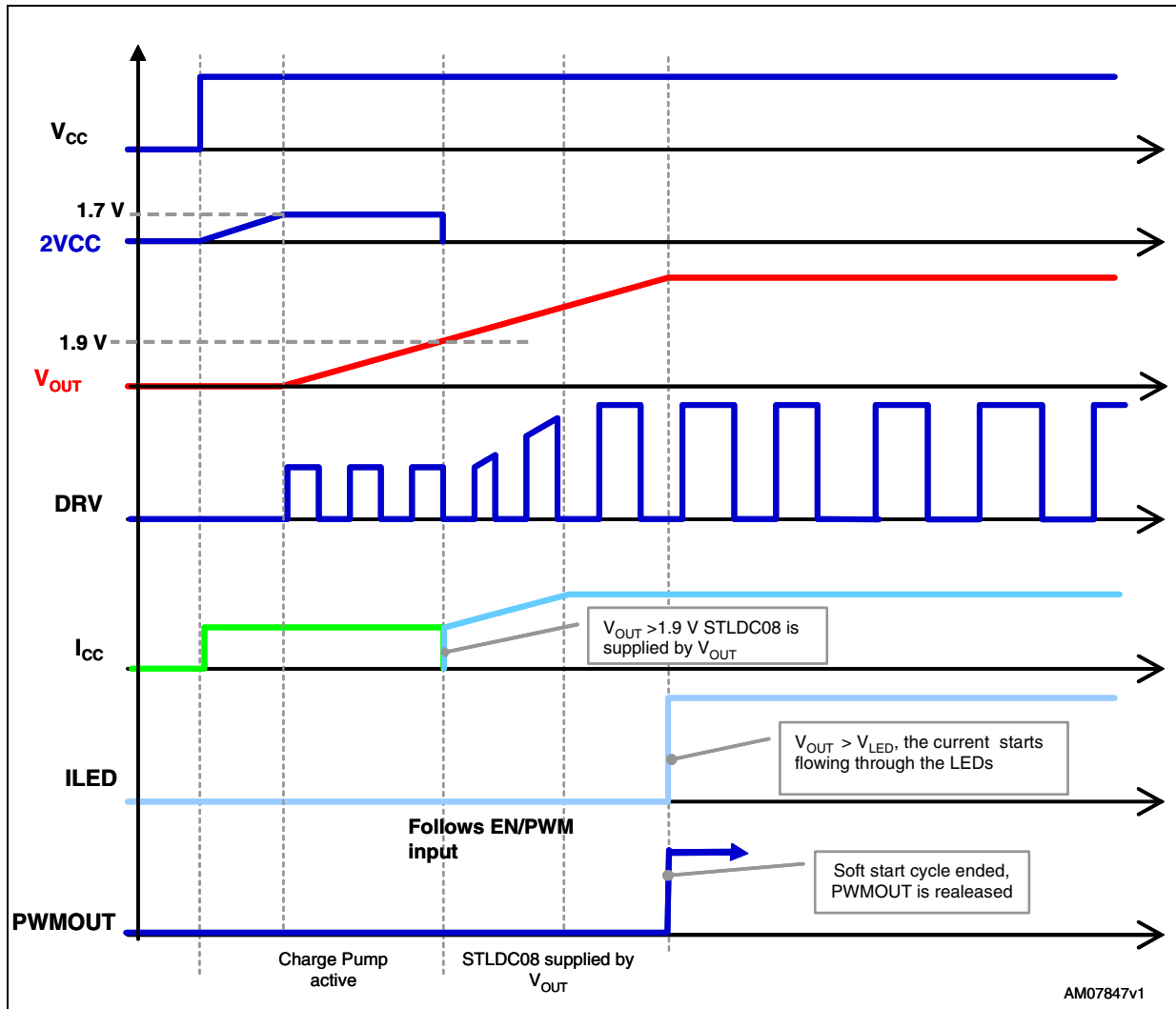

7.3 Over voltage protection (OVP)

As with any current source, the output voltage rises when the output gets high impedance or is disconnected. To prevent the output voltage exceeding the maximum switch voltage rating of the main switch, an overvoltage protection circuit is integrated. As soon as the output voltage exceeds the OVP threshold, the converter stops switching and the output voltage drops. When the output voltage falls below the OVP threshold, the converter continues operation until the output voltage exceeds the OVP threshold again.

7.4 Enable/PWM

The enable pin allows disabling and enabling of the device as well as brightness control of the LEDs by applying a PWM signal. In order to avoid visible flicker, the frequency of the PWM signal should be higher than 120 Hz. Changing the PWM duty cycle therefore changes the LED brightness.

7.5 Dimming

When PWMOUT goes to zero, the LED current immediately goes to zero and the energy stored in the coil is discharged on the output capacitor, causing an increase in the output voltage. As soon as the PWM goes back to high value, there is a big spike current on the LED. This could damage the LED itself. To avoid this, as soon as the input PWM signal goes to zero the controller immediately turns off the main switch (in order to discharge the coil current on the LED branch). In this way the PWM power is turned off with a delay in order to guarantee that FB goes high after PowerMOS turn off. After this delay, the flip-flop is ready to be set and the PWM power is turned off. In this condition the output voltage is slightly lower than the regulated value, but a current spike on the LED is avoided.

8 Application information

8.1 LED current programming

The LED current is set by an external resistor connected between the FB pin and GND. The following equation can be used to calculate the value of the R_{FB} resistor which guarantees the desired output current:

Equation 1

$$R_{FB} = \frac{0.1}{I_{LED}}$$

The feedback signal V_{FB} is compared with the internal precision 100 mV voltage reference by the error amplifier. The internal reference has a guaranteed tolerance of 10 %. Tolerance of the sense resistor adds additional error to the output voltage. 1 % resistors are recommended.

8.2 Duty cycle

The controlled off-time architecture is a hysteretic mode control. Hysteretic operation eliminates the need for small signal control loop compensation. When the converter runs in continuous conduction mode (CCM) the controller adapts the T_{ON} time in order to obtain the duty cycle given by the following relationship:

Equation 2

$$D = 1 - \frac{V_{IN}}{V_{OUT} + V_D}$$

where V_O is the output voltage given by:

Equation 3

$$V_O = n \times V_{F(LED)} + V_{FB}$$

and V_D is the forward voltage of the Schottky diode.

8.3 Inductor selection

As the hysteretic control scheme is inherently stable, the inductor value does not affect the stability of the regulator. The switching frequency, peak inductor current, and allowable ripple of the output current determine the value of the inductor.

LED manufacturers generally recommend a value for LED current ripple ranging from 5 % to 20 % of LED average current.

As a first approximation we choose the inductor ripple current, I_L , equal to approximately 40 % of the output current. Higher ripple current allows for smaller inductors, but it also increases the output capacitance for a given LED current ripple requirement. Conversely, lower ripple current can be obtained increasing the value of the inductance, and this enables a reduction of the output capacitor value. This trade-off can be altered once standard inductance and capacitance values are chosen.

I_L is determined by the input and output voltage, the value of the inductance, and T_{OFF}

Figure 18. Timing diagram

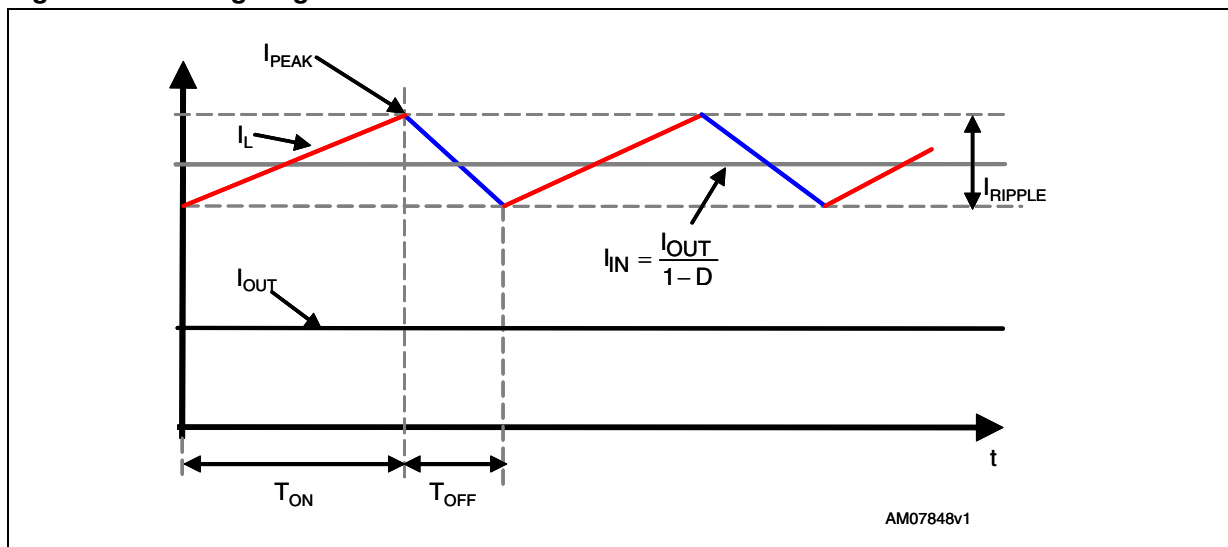

The minimum value of inductance which guarantees the fixed inductor ripple current can be determined using the following equation:

Equation 4

$$L > \frac{(V_{OUT} + V_d - V_{INMIN})}{(\Delta I_L)} \times T_{OFF}$$

where V_d is the forward drop of the Schottky diode, I_L is the fixed inductor ripple current, and T_{OFF} is the constant OFF time.

The following equation shows the average inductor current as a function of the output current and duty cycle.

Equation 5

$$I_{L(AVG)} = \frac{I_{LED}}{1-D}$$

An inductor that can carry the maximum input DC current which occurs at the minimum input voltage should be chosen. The peak-to-peak ripple current is set by the inductance and a good starting point is to choose a ripple current of at least 40 % of its maximum value of the:

Equation 6

$$\Delta I_L = 40\% \times I_{L(AVG)} = 40\% \times \frac{I_{LED}}{1 - D_{MAX}}$$

Where D_{MAX} is given by:

Equation 7

$$D_{MAX} = 1 - \frac{V_{IN(MIN)}}{V_{OUT} + V_D}$$

The value of the peak current on the inductor is given by the following equation:

Equation 8

$$I_{L(PK)} = I_{L(AVG)} + \frac{\Delta I_L}{2}$$

The minimum required saturation current of the inductor must be greater than $I_{L(PK)}$ and can be expressed as follows:

Equation 9

$$I_{L(SAT)} > I_{L(PK)} = \frac{I_{OUT}}{1 - D_{MAX}} + \frac{\Delta I_L}{2}$$

The saturation current rating for the inductor should be checked at the maximum duty cycle and maximum output current.

8.4 Inductor peak current limit

The value of the inductor peak current limit can be programmed either by using a sense resistor or by using the R_{DSON} of the main Power MOSFET.

The following equation gives the relationship between the peak current limit and the value of the sense resistor:

Equation 10

$$I_{IN(MAX)} = \frac{V_{SENSE}}{R_{SENSE}} = \frac{0.1}{R_{SENSE}}$$

The sense resistor value can be determined fixing the value of the inductor peak current limit equal to twice the value of the inductor peak current in steady-state conditions.

Equation 11

$$I_{N(MAX)} = 2 \times I_{L(PK)}$$

Equation 12

$$I_{L(PK)} = \frac{I_{LED}}{1 - D_{MAX}} + \frac{\Delta I_L}{2}$$

Equation 13

$$R_{SENSE} = \frac{0.1}{2 \times I_{L(PK)}}$$

If the $R_{DS(ON)}$ of the main Power MOSFET is used to sense the current on the inductor the following procedure must be performed to choose the Power MOSFET. During ON time, the SENSE comparator limits the voltage across the Power MOSFET to a nominal 100 mV. In that case, the maximum inductor current is given by the following relationships:

Equation 14

$$I_{L(MAX)} = \frac{V_{SENSE}}{R_{DS(ON)}} = \frac{100mV}{R_{DS(ON)}}$$

Equation 15

$$I_{L(MAX)} = 2 \times I_{L(PK)} = 2 \times \frac{I_{LED}}{1 - D_{MAX}} \times \left(1 + \frac{\Delta I_L}{2}\right)$$

Equation 16

$$R_{DS(ON)} < 0.1 \times \frac{1 - D_{MAX}}{2 \times I_{LED} \times \left(1 + \frac{\Delta I_L}{2}\right)}$$

8.5 Power MOSFET selection

A key parameter to take into account in the selection of the N-MOSFET is the maximum continuous drain current. As a safety design, it is important to choose a maximum continuous drain current equal to twice the maximum input current.

Figure 19. Current diagram ON state

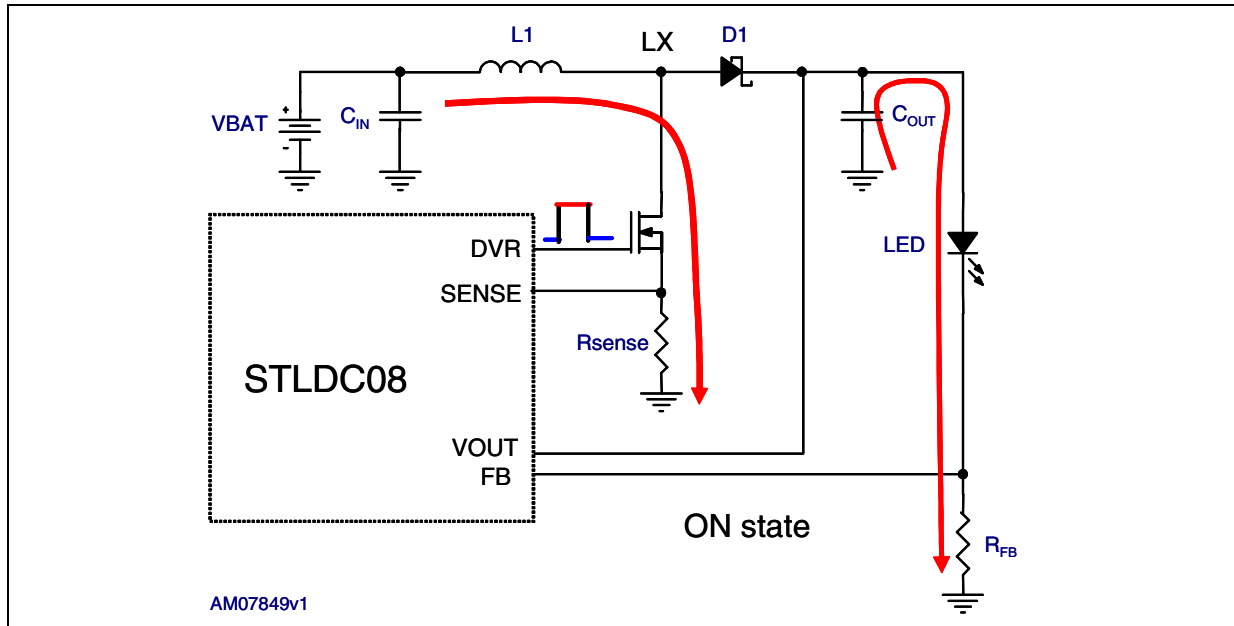

AM07849v1

Figure 20. Current diagram OFF state

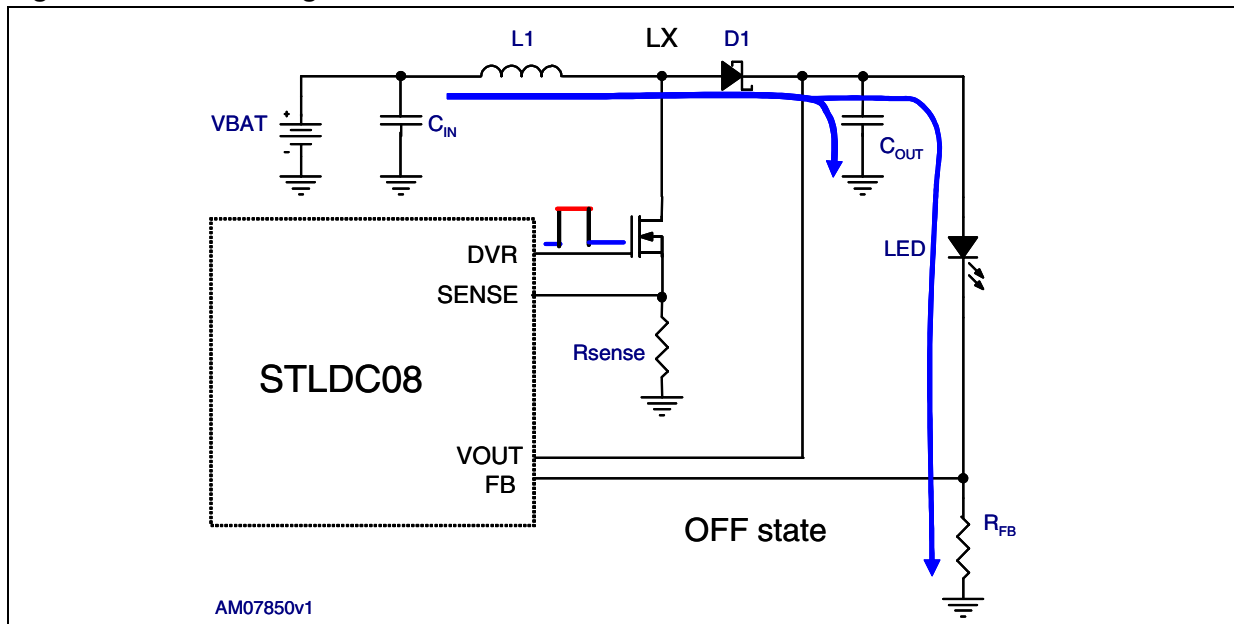

AM07850v1

Another important parameter is the drain source breakdown voltage. During the ON state, the potential of the LX point is 0 V, while during the OFF state the potential of this point rises to the output voltage plus the forward voltage of the D1. Therefore, the absolute V_{DS} rating of the main switch must be greater than this voltage to prevent main switch damage.

8.6 Schottky diode selection

Schottky diodes, with their low forward voltage and fast recovery time, are the ideal choice to maximize efficiency. The output diode in a boost converter conducts current only when the power switch is OFF. The average current is equal to the output current and the peak current is equal to the peak inductor current. Ensure that the diode's average and peak current ratings exceed the average and peak inductor current, respectively. In addition, the diode's reverse breakdown voltage must exceed the regulator output voltage.

8.7 Input capacitor

The input capacitor of a boost converter is less critical than the output capacitor, due to the fact that the input current waveform is continuous. The input voltage source impedance determines the size of the input capacitor, which is typically in the range of 10 μF to 100 μF . A low ESR capacitor is recommended though it is not as critical as the output capacitor.

8.8 Output capacitor

For best output voltage filtering, a low ESR output capacitor is recommended. Ceramic capacitors have a low ESR value but tantalum capacitors can be used as well, depending on the application.

The output voltage ripple consists of two parts, the first is the product $I_{L(PK)} \text{ ESR}$, the second is caused by the charging and discharging process of the output capacitor.

Equation 17

$$\Delta V_{\text{OUT}} = \frac{T_{\text{ON}} \times I_{\text{LED}}}{C_{\text{OUT}}} + \text{ESR} \times I_{L(PK)}$$

where:

$I_{L(PK)}$ = Peak current

I_{LED} = Load current

C_{OUT} = Selected output capacitor

ESR = Output capacitor ESR value

9 Demonstration board

Figure 21. Electrical schematic

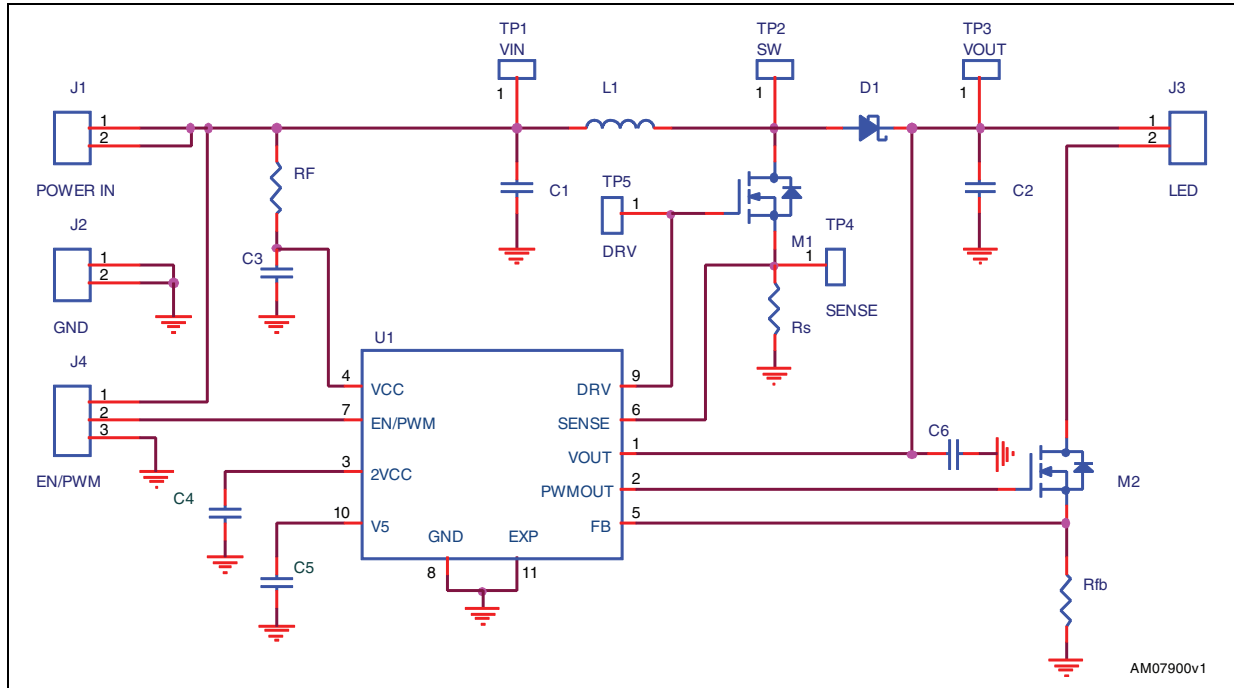

Table 8. Bill of material optimized for 2 LEDs and $I_{LED} = 200\text{ mA}$

Reference	Manufacturer	Part number	Value	Size
C1	Murata	GRM21BR60J475	4.7 μF 6.3V	0805
C2	Murata	GRM31CB31C106K	10 μF 16 V	1206
C4	Murata	GRM188R70J103KA01B	10 nF, 6.3 V	0603
C3, C5, C6	Murata	GRM188R61C105K	1 μF , 16 V	0603
L	Coilcraft	LPS6235-103ML	10 μH	6 mm x 6 mm
M1,M2	STMicroelectronics	STS5DNF20V		SO-8
D1	STMicroelectronics	STPS2L30		SMA
Rfb			0.47 Ω	0805
Rs			0.047 Ω	0805
RF			0 Ω	

10 Layout suggestion

Figure 22. Assembly layer

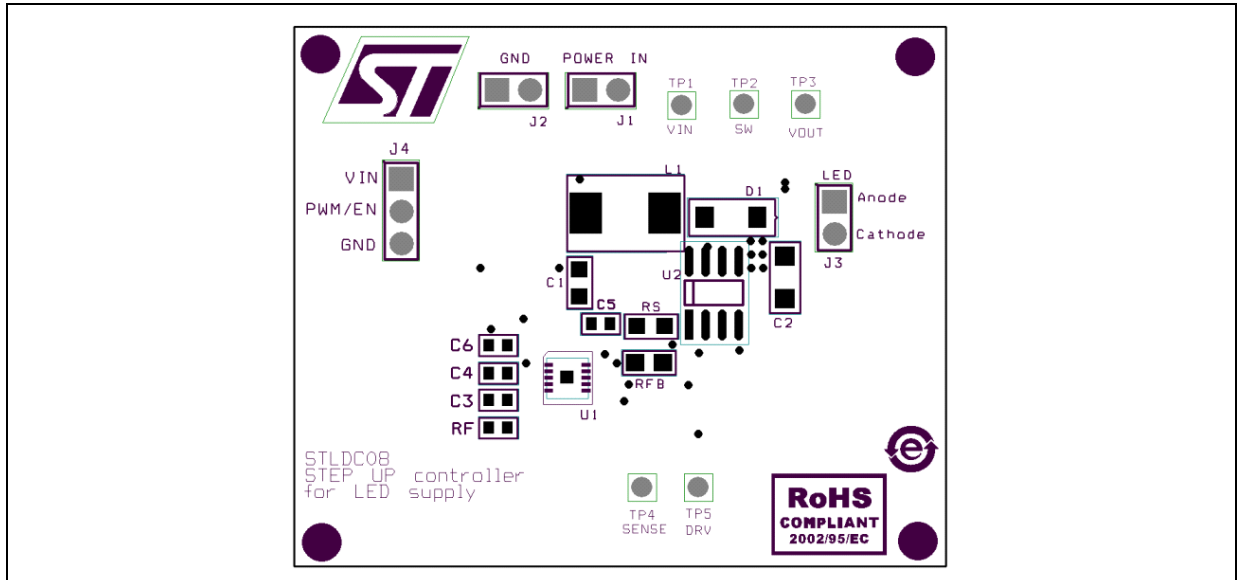

Figure 23. Top layer

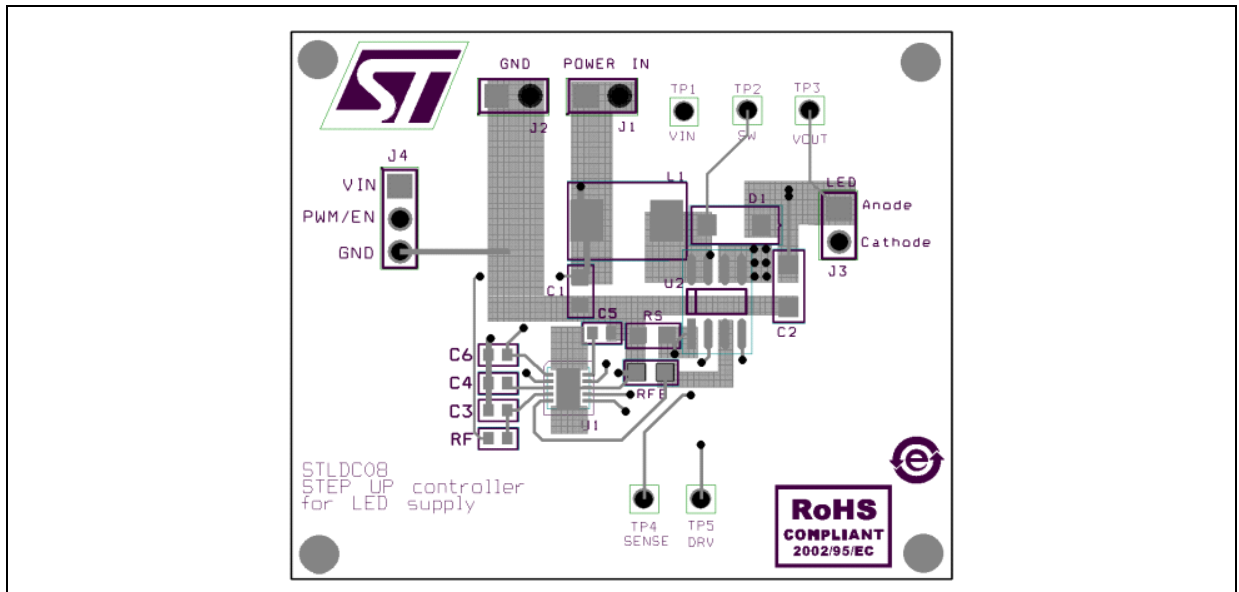
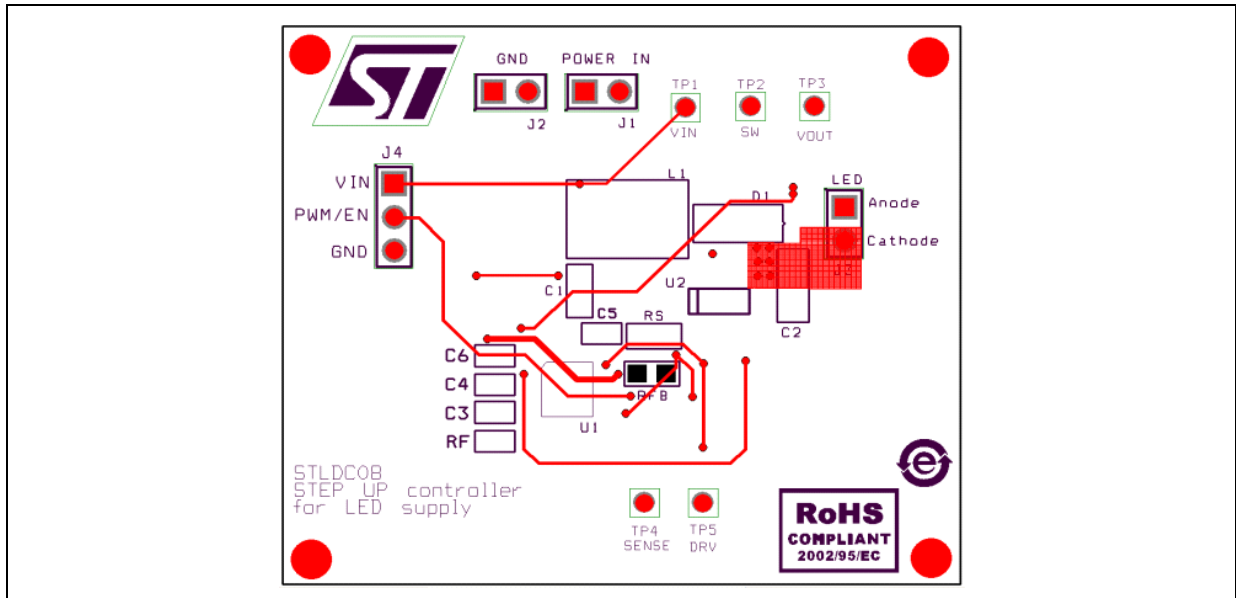

Figure 24. Bottom layer



11 Package mechanical data

In order to meet environmental requirements, ST offers these devices in different grades of ECOPACK® packages, depending on their level of environmental compliance. ECOPACK® specifications, grade definitions and product status are available at: www.st.com. ECOPACK® is an ST trademark.

DFN10 (3x3 mm) mechanical data

Dim.	mm.			mils.		
	Min.	Typ.	Max.	Min.	Typ.	Max.
A	0.80	0.90	1.00	31.5	35.4	39.4
A1		0.02	0.05		0.8	2.0
A2	0.55	0.65	0.80	21.7	25.6	31.5
A3		0.20			7.9	
b	0.18	0.25	0.30	7.1	9.8	11.8
D	2.85	3.00	3.15	112.2	118.1	124.0
D2	2.20			86.6		
E	2.85	3.00	3.15	112.2	118.1	124.0
E2	1.40		1.75	55.1		68.9
e		0.50			19.7	
L	0.30	0.40	0.50	11.8	15.7	19.7
ddd			0.08			3.1

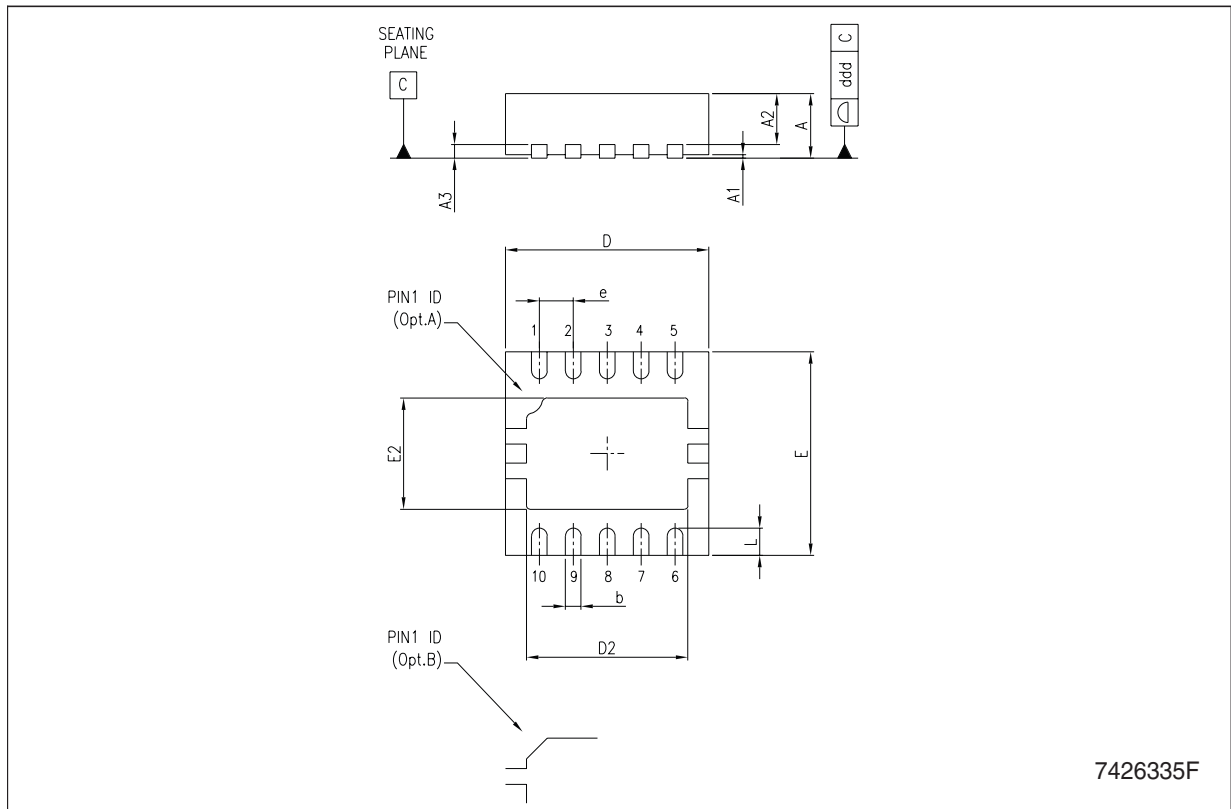

Tape & reel QFNxx/DFNxx (3x3) mechanical data

Dim.	mm.			inch.		
	Min.	Typ.	Max.	Min.	Typ.	Max.
A			180			7.087
C	12.8		13.2	0.504		0.519
D	20.2			0.795		
N	60			2.362		
T			14.4			0.567
Ao		3.3			0.130	
Bo		3.3			0.130	
Ko		1.1			0.043	
Po		4			0.157	
P		8			0.315	

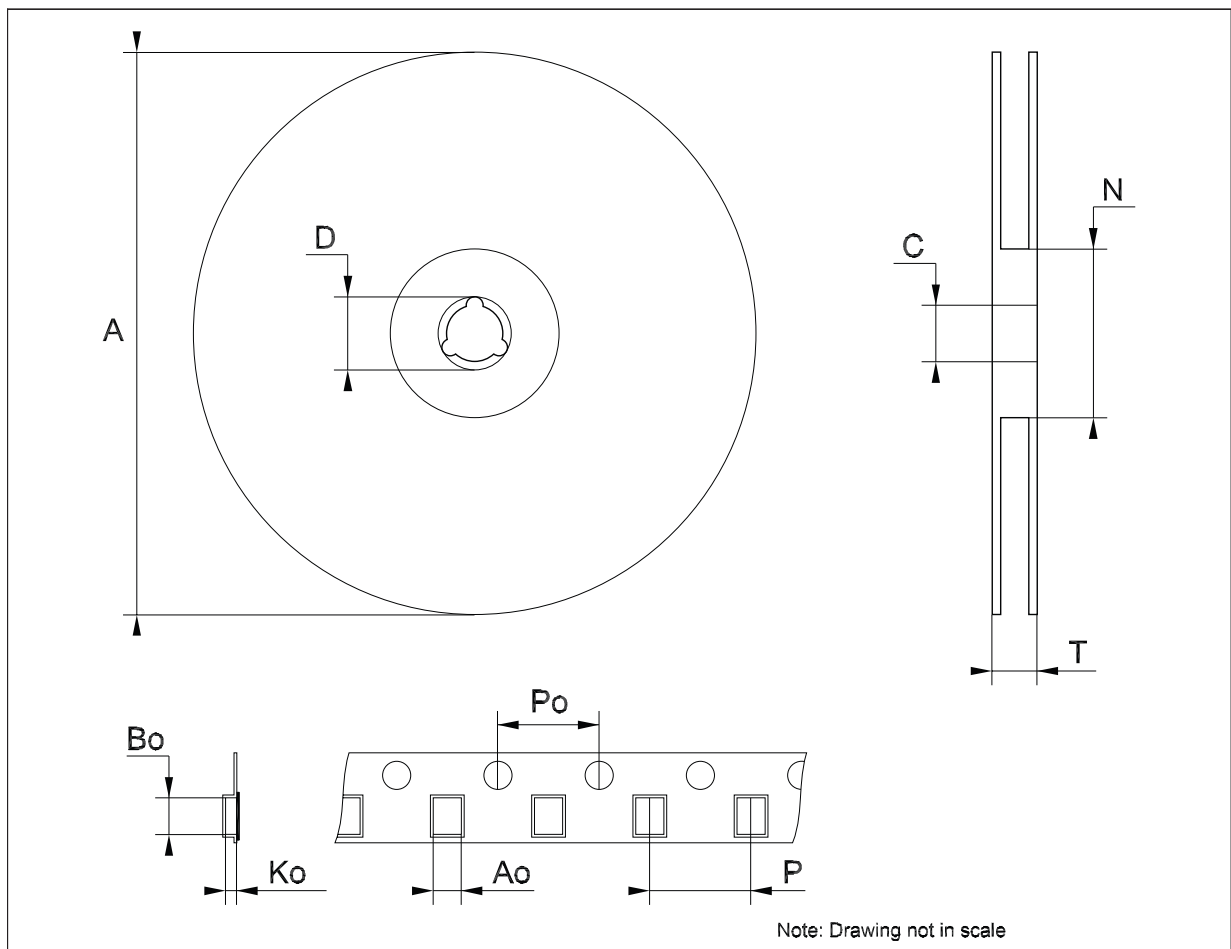

12 Revision history

Table 9. Document revision history

Date	Revision	Changes
22-Feb-2011	1	First release.