

STN265033U380

TVS Diode array ESD suppressor

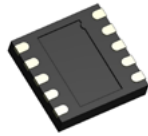

Product features

- 450 Watts peak pulse power per line ($t_p = 8/20 \mu s$)
- Protects four I/O lines and one V_{CC} line
- Low clamping voltage
- Ultra low capacitance: <3 pF for high-speed interfaces
- Working voltage: 3.3 V
- Low leakage current
- Meets moisture sensitivity level (MSL) 3
- Molding compound flammability rating: UL 94V-0
- Termination finish: Ni/Pd/Au

Applications

- USB interfaces
- 10/100/1000 ethernet
- DVI interfaces
- Wireless data (WAN/LAN) systems
- Analog video
- T1/E1 secondary protection
- T3/E3 secondary protection

Environmental compliance and general specifications

- IEC61000-4-2 (ESD)
 - ± 30 kV (air)
 - ± 30 kV (contact)
- IEC61000-4-5 (Lightning) 25 A (8/20 μs)



Ordering part number

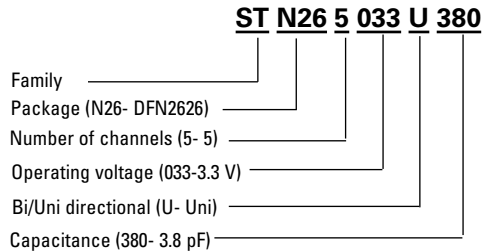

Pin out/functional diagram

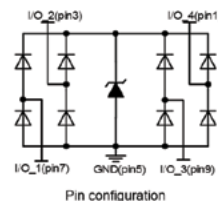
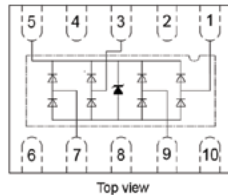
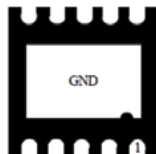

Absolute maximum ratings

(+25 °C, RH=45%-75%, unless otherwise noted)

STN265033U380

Parameter	Symbol	Value	Unit
Peak pulse power dissipation on 8/20 μs waveform	P_{PP}	450	W
ESD per IEC 61000-4-2 (Air)	V_{ESD}	+/-30	kV
ESD per IEC 61000-4-2 (Contact)		+/-30	
Lead soldering temperature	T_L	+260 (10 seconds)	°C
Operating junction temperature range	T_J	-55 to +125	°C
Storage temperature range	T_{STG}	-55 to +150	°C

Electrical characteristics

(+25 °C)

STN265033U380

Parameter	Test condition	Minimum	Typical	Maximum	Symbol (Units)
Reverse working voltage	Any pin to ground	-	-	3.3	V_{RWM} (V)
Reverse breakdown voltage	$I_r = 1$ mA pin to ground	3.7	-	-	V_{BR} (V)
Reverse holding voltage	$I_h = 50$ mA	3.5	-	-	V_h (V)
Reverse leakage current	$V_{RWM} = 3.3$ V	-	-	0.1	I_R (μA)
Clamping voltage	$I_{PP} = 5$ A, $t_p = 8/20$ μs I/O pin to GND	-	-	10	V_c (V)
	$I_{PP} = 25$ A, $t_p = 8/20$ μs I/O pin to GND	-	-	16	V_c (V)
Junction capacitance	$V_{RWM} = 0$ V, $f = 1$ MHz Between I/O pins	-	2	-	C_j (pF)
	$V_{RWM} = 0$ V, $f = 1$ MHz I/O pin to GND	-	3.8	5	C_j (pF)

Mechanical parameters, pad layout- mm/inches

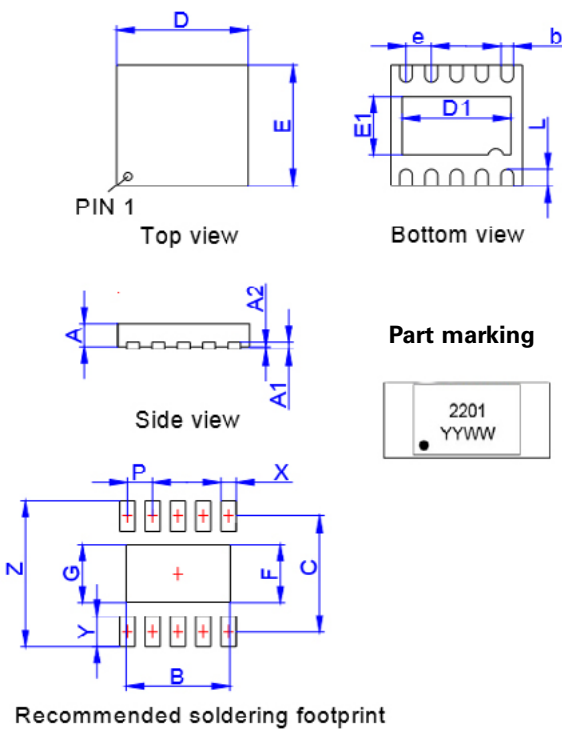

Dimension	Millimeters			Inches		
	Minimum	Typical	Maximum	Minimum	Typical	Maximum
D	2.55	2.60	2.65	0.100	0.102	0.104
E	2.55	2.60	2.65	0.100	0.102	0.104
D1	2.10	2.15	2.20	0.083	0.085	0.087
E1	1.21	1.26	1.31	0.048	0.050	0.052
L	0.30	0.35	0.40	0.012	0.014	0.016
b	0.20	0.25	0.30	0.008	0.010	0.012
e	0.50 BSC			0.020 BSC		
A	0.45	0.50	0.55	0.018	0.020	0.022
A1	0.15 REF			0.006 REF		
A2	0.00	0.02	0.05	0.000	0.001	0.002
B	2.05			0.081		
C	2.50			0.098		
F	1.26			0.050		
G	1.85			0.073		
P	0.50			0.020		
X	0.30			0.012		
Y	0.65			0.026		
Z	3.15			0.124		

Packaging information mm/inches

Drawing not to scale.

Supplied in tape and reel packaging, 3,000 parts per 7" diameter reel (EIA-481 compliant)

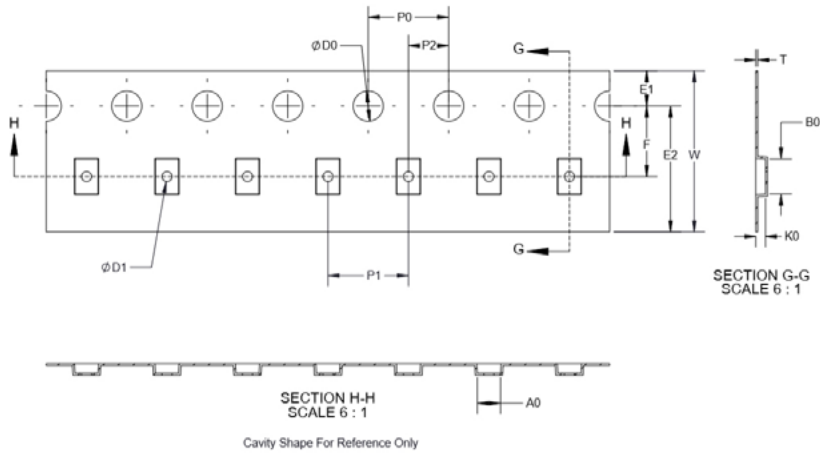

W	8.00
F	3.50
E1	1.75
E2	N/A
P0	4.00
P1	4.00
P2	2.00
ØD0	1.50
ØD1	N/A
A0	2.73
B0	2.78
K0	0.97
T	N/A

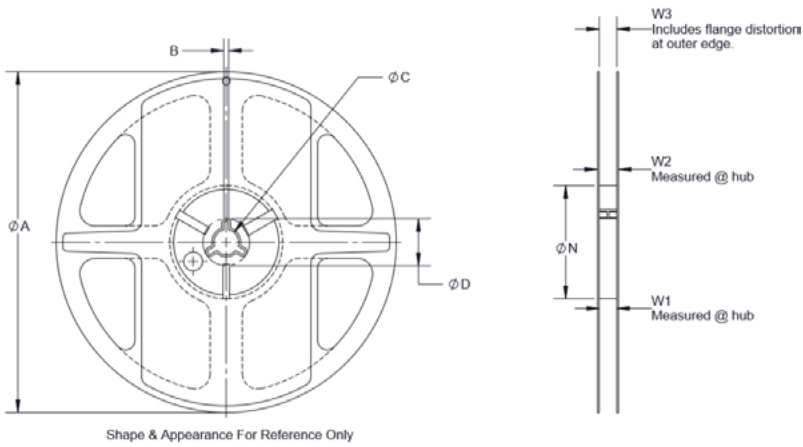

A	178.00
B	N/A
C	13.00
D	N/A
N	54.40
W1	9.50
W2	12.30
W3	N/A

Ratings and V-I characteristic curves (+25 °C unless otherwise noted)

V- I curve characteristics (Uni-directional)

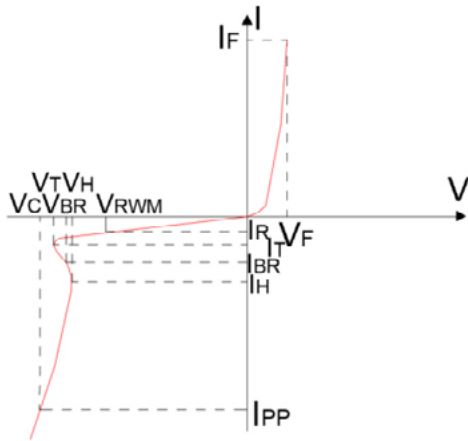

Pulse waveform (8/20 μs)

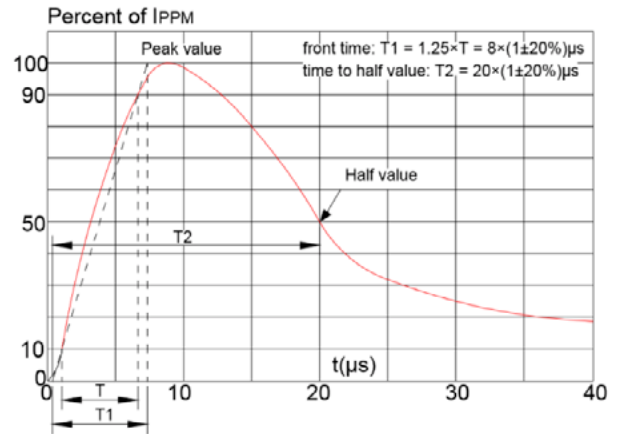

Pulse derating curve

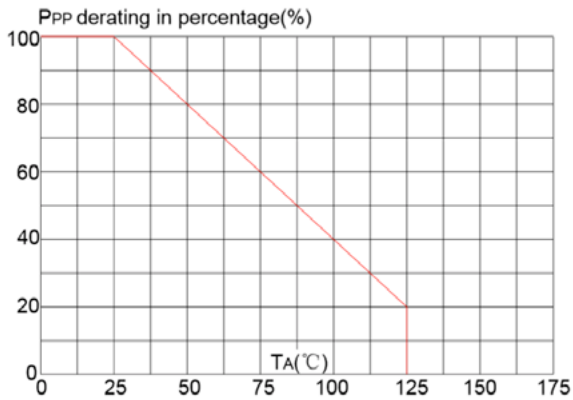

ESD waveform

