

## 2 kV NPN Darlington transistor

### Features

- Extra high voltage capability
- High gain characteristic

### Application

- Active start-up network in 3 phase S.M.P.S. (see application note AN2454)

### Description

The STP03D200 is made by two extra high voltage NPN transistors in Darlington configuration housed in a single package. The resulting device shows high gain performance.

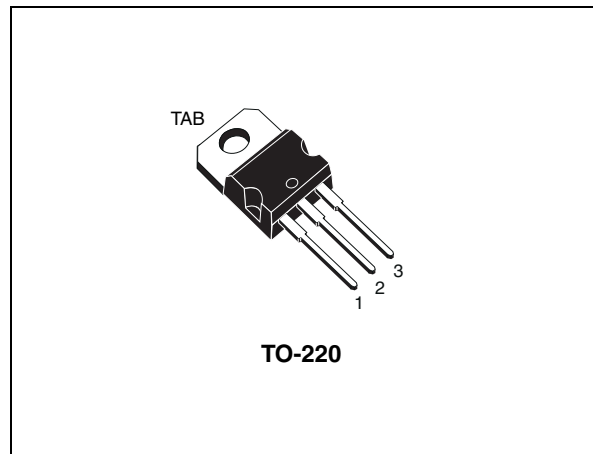

**Figure 1. Internal schematic diagram**

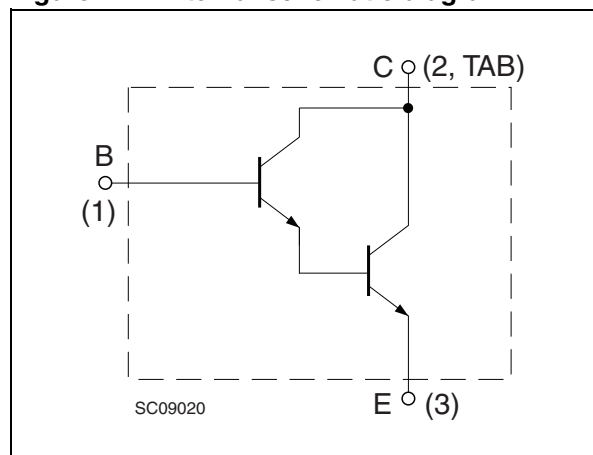

**Table 1. Device summary**

Order code	Marking	Package	Packaging
STP03D200	P03D200	TO-220	Tube

# 1 Electrical ratings

**Table 2. Absolute maximum ratings**

Symbol	Parameter	Value	Unit
$V_{CBO}$	Collector-base voltage ( $I_E = 0$ )	2000	V
$V_{CEO}$	Collector-emitter voltage ( $I_B = 0$ )	1200	V
$V_{EBO}$	Emitter-base voltage ( $I_C = 0$ )	20	V
$I_C$	Collector current	100	mA
$I_{CM}$	Collector peak current ( $t_P < 5$ ms)	200	mA
$P_{TOT}$	Total dissipation at $T_C = 25$ °C	40	W
$T_{STG}$	Storage temperature	-65 to 150	°C
$T_J$	Max. operating junction temperature	150	°C

**Table 3. Thermal data**

Symbol	Parameter	Value	Unit
$R_{thJC}$	Thermal resistance junction-case max	3.13	°C/W

## 2 Electrical characteristics

$T_{CASE} = 25\text{ °C}$  unless otherwise specified.

**Table 4. Electrical characteristics**

Symbol	Parameter	Test conditions	Min.	Typ.	Max.	Unit
$I_{CBO}$	Collector cut-off current ( $I_E = 0$ )	$V_{CB} = 2000\text{ V}$			100	$\mu\text{A}$
$I_{CEO}$	Collector cut-off current ( $I_B = 0$ )	$V_{CE} = 1200\text{ V}$			100	$\mu\text{A}$
$V_{(BR)CEO}$	Collector-emitter breakdown voltage ( $I_B = 0$ )	$I_C = 1\text{ mA}$	1200			V
$V_{EBO}$	Emitter-base voltage ( $I_C = 0$ )	$I_E = 10\text{ }\mu\text{A}$	20			V
$V_{CE(sat)}^{(1)}$	Collector-emitter saturation voltage	$I_C = 50\text{ mA}; I_B = 500\text{ }\mu\text{A}$			2	V
$V_{BE(sat)}^{(1)}$	Base-emitter saturation voltage	$I_C = 50\text{ mA}; I_B = 500\text{ }\mu\text{A}$			2	V
$h_{FE}$	DC current gain	$I_C = 20\text{ mA}; V_{CE} = 10\text{ V}$ $I_C = 30\text{ mA}; V_{CE} = 10\text{ V}$	230 200			

1. Pulse test: pulse duration  $\leq 300\text{ }\mu\text{s}$ , duty cycle  $\leq 2\%$

### 3 Package mechanical data

In order to meet environmental requirements, ST offers these devices in different grades of ECOPACK<sup>®</sup> packages, depending on their level of environmental compliance. ECOPACK<sup>®</sup> specifications, grade definitions and product status are available at: [www.st.com](http://www.st.com). ECOPACK<sup>®</sup> is an ST trademark.

**TO-220 type A mechanical data**

Dim	mm		
	Min	Typ	Max
A	4.40		4.60
b	0.61		0.88
b1	1.14		1.70
c	0.48		0.70
D	15.25		15.75
D1		1.27	
E	10		10.40
e	2.40		2.70
e1	4.95		5.15
F	1.23		1.32
H1	6.20		6.60
J1	2.40		2.72
L	13		14
L1	3.50		3.93
L20		16.40	
L30		28.90	
∅P	3.75		3.85
Q	2.65		2.95

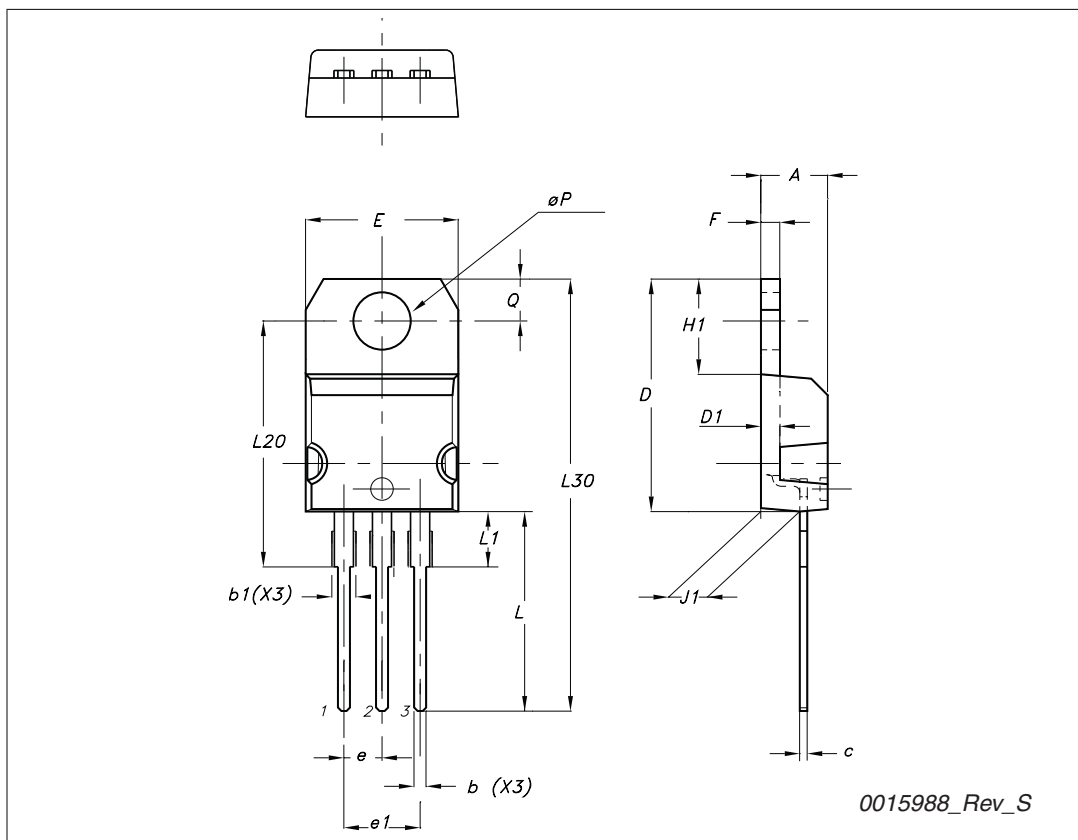

## 4 Revision history

**Table 5. Document revision history**

Date	Revision	Changes
22-Oct-2007	1	Initial release.
19-Feb-2010	2	Document status promoted from preliminary data to datasheet, modified $h_{FE}$ minimum values <a href="#">Table 4 on page 3</a> .