

STR-ECS640A-GEVB Evaluation Board User's Manual

EVBUM2816/D

Description

This user manual provides practical guidelines for the evaluation board with the new **onsemi** ecoSpin motor controller ECS640A and its main features, which are Arm[®] Cortex[®]-M0+ microcontroller, embedded gate drivers, operational amplifiers and bootstrap diodes. This module may be configured for the control of sinusoidal or trapezoidal motors and its default software enables some basic capabilities when used with the Strata Developer Studio. An isolated J-link on-board circuit is available for the user.

The board was developed to support customers during their first steps designing applications with the ECS640A configurable motor control system. The design was tested as described in this document but not qualified regarding safety requirements or manufacturing and operation over the entire operating temperature range or lifetime. The board is intended for functional testing under laboratory conditions and by trained specialists only.

Features

- Single ECS640A Packaged Device, containing Logic Controller, Gate-drivers and Operational Amplifiers
- Output Power up to 650 W
- Voltage-doubler enables Bus Configuration for 110 V or 220 V Input Voltages
- Configurable Motor Control Methods for Trapezoidal or Vector-oriented (FOC and DTFC) Motor Applications
- Isolated J-link On-board
- Power Stage Inverter composed of 6 **onsemi** IGBTs (FGPF15N60UNDF)
- User-friendly GUI. ecoSpin Motor Controller Interface is a GUI designed to do Fine Tuning in Motor Control Applications
- NCP10970 DC/DC Converter designed to provide both 15 VDC (Buck Topology) and 3.3 VDC (Embedded LDO)



Figure 1. Evaluation Board Photo

EVBUM2816/D

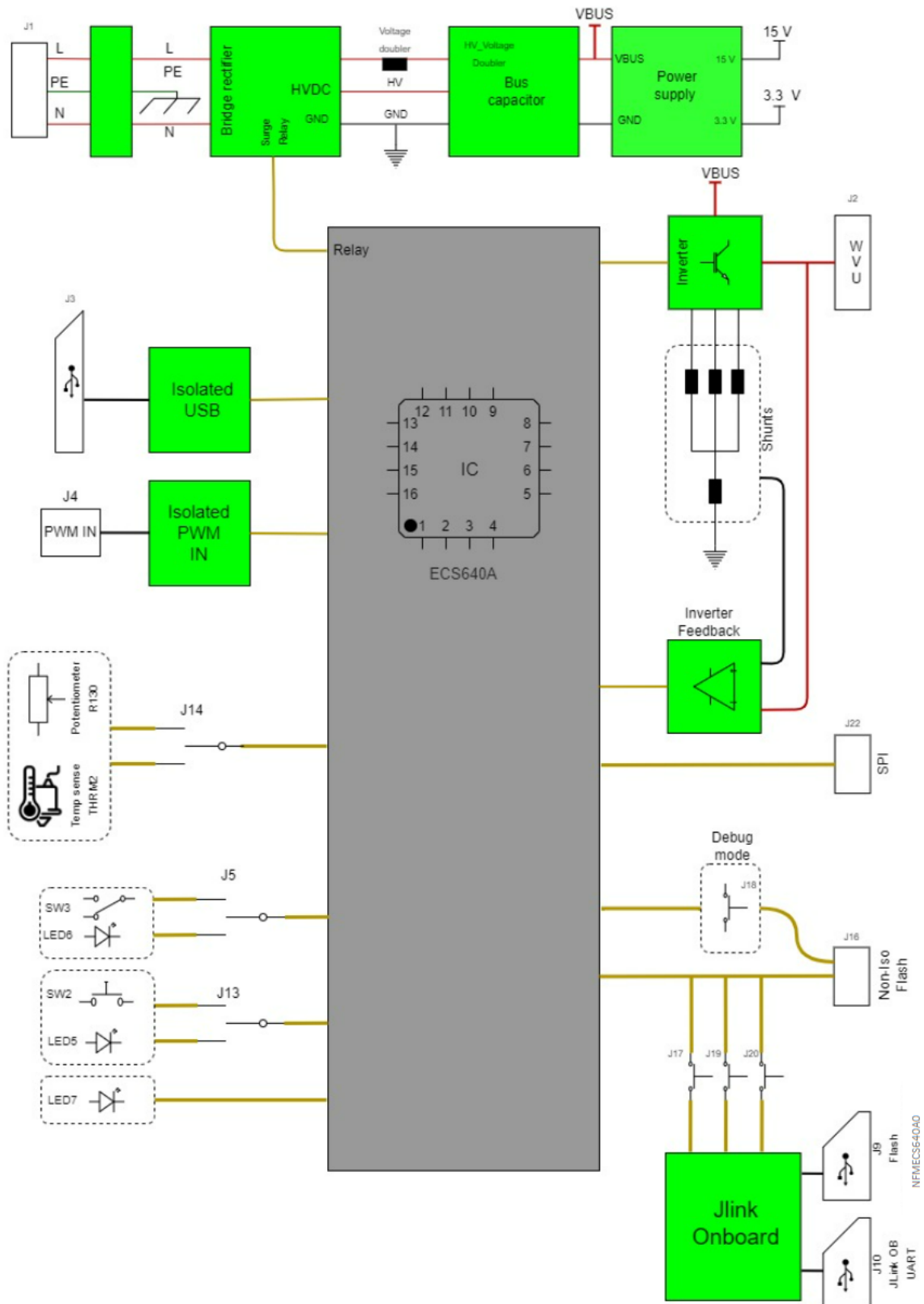

Figure 2. Simplified Block Diagram

EVBUM2816/D

VOLTAGE MAP

Figure 3 identifies voltage potential per area of the STR-ECS640A-GEVB.

AREA 1

Voltage is up to 20 V with regards to the negative DC bus voltage potential (Low voltage non-isolated)

AREA 2

Voltage isolated from Area 1 GND reference. Maximum internal voltage drop of 5 V \pm 5%

AREA 3

Voltage isolated from Area 1 GND reference. Maximum internal voltage drop of 5 V \pm 5%

AREA 4

Voltage isolated from Area 1 GND reference. PWM_IN step is operational for supply signal from 5 V up to 12 V between its inputs.

AREA 5

High voltage non-isolated.

Areas 2, 3 and 4 do not share their reference signal necessarily, but it is strongly advised to not short the reference signal from Area 1 with any other Area since the others might carry Protective Earth, Line or Neutral signals.

Area 1 connectors: J15, J16, J22.

Area 2 connectors: J8, J9, J10.

Area 3 connectors: J3.

Area 4 connectors: J4.

Area 5 connectors: J1, J2.

See Figure 7 to check the high voltage connectors positions.

See Figure 9 to check the low voltage connectors positions.

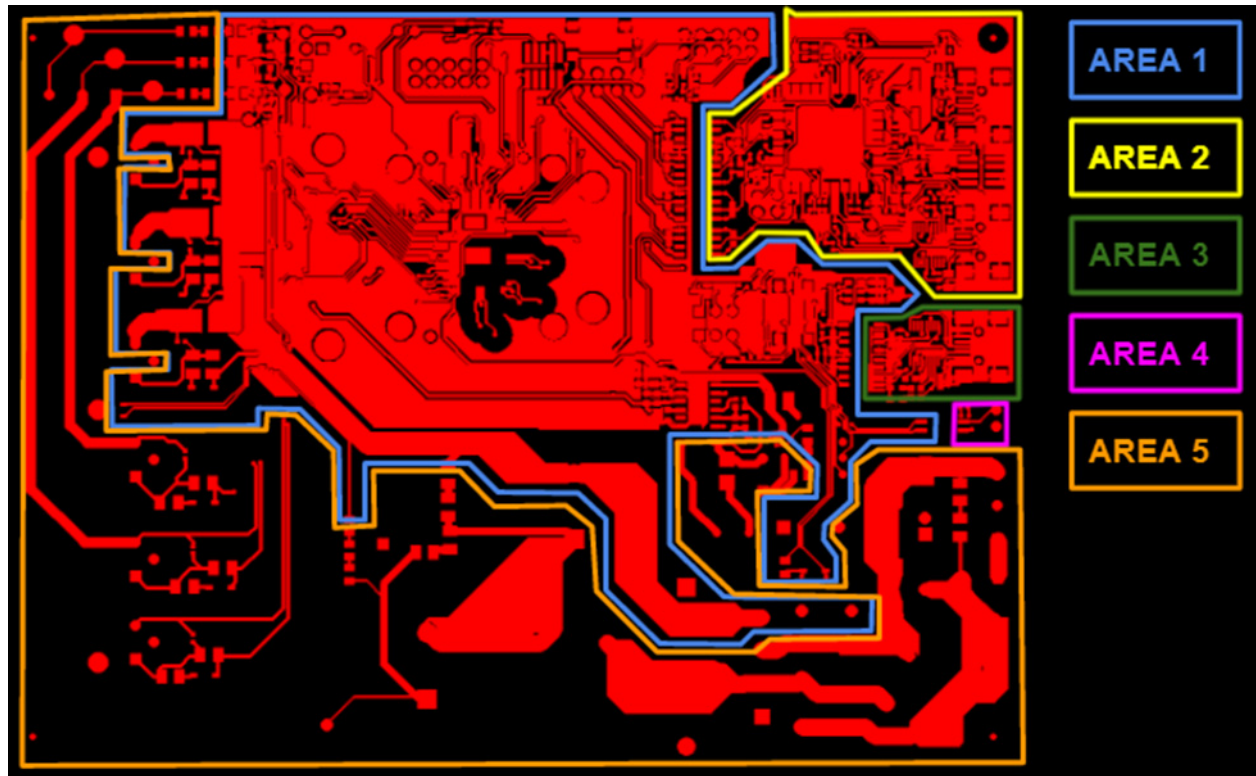











Figure 3. Voltage Map

EVBUM2816/D

SAFETY PRECAUTIONS

It is **mandatory** to read the following precautions before manipulating the STR–ECS640A–GEVB.

	The ground potential of Areas 1 and 5 (see Voltage Map section) is biased to a negative DC bus voltage potential. When connecting an oscilloscope probe to these areas, the scope's ground needs to be isolated. Failure to do so may result in personal injury or death.
	The connectors inside Areas 1 and 5 (see Voltage Map section) are NOT biased to an earth (PE) potential. It is recommended to isolate the signals before any connection is made to Area 1 and/or 5.
	STR–ECS640A–GEVB system contains DC bus capacitors which take time to discharge after removal of the main supply. Before touching the module, wait ten minutes for capacitors to discharge to safe voltage levels. Failure to do so may result in personal injury or death.
	Only personnel familiar with the drive and associated machinery should plan or implement the installation, start-up and subsequent maintenance of the system. Failure to comply may result in personal injury and/or equipment damage.
	The surfaces of the heat sink may become hot, which may cause injury.
	STR–ECS640A–GEVB system contains parts and assemblies that are sensitive to Electrostatic Discharge (ESD). Electrostatic control precautions are required when installing, testing, servicing or repairing this assembly. ESD control procedures not followed may lead to component damage. If you are not familiar with electrostatic control procedures, refer to applicable ESD protection handbooks and guidelines.
	A drive, incorrectly applied or installed, can result in component damage or reduction in product lifetime. Wiring or application errors such as under sizing the motor, supplying an incorrect or inadequate AC supply or excessive ambient temperatures may result in system malfunction.
	Remove and lock out power from the drive before you disconnect or reconnect wires or perform service. Wait ten minutes after removing power to discharge the bus capacitors. Do not attempt to service the drive until the bus capacitors have discharged to zero. Failure to do so may result in personal injury or death.
	Voltage doubler can be used only with 110 V rms power input, the use of the doubler when 220 V rms input may result in personal injury or death.

MAXIMUM RATINGS

Rating	Symbol	Value	Unit
Input Voltage Range (Note 1)	V_{in}	230	V_{ac}
Output Power	P_{out}	650	W
Current per Inverter Leg	I_{out}	2.6	A_{rms}
Overcurrent Protection		4	A_{peak}
Operation Temperature	T_{max}	–20 to 105	$^{\circ}C$

Stresses exceeding those listed in the Maximum Ratings table may damage the device. If any of these limits are exceeded, device functionality should not be assumed, damage may occur and reliability may be affected.

1. Refer to ELECTRICAL CHARACTERISTICS, RECOMMENDED OPERATING RANGES and/or APPLICATION INFORMATION for Safe Operating parameters.

RECOMMENDED OPERATING RANGES

Rating	Symbol	Min	Max	Unit
Input Voltage	V_{in}	24	230	V_{ac}
Ambient Temperature	T_A	–20	60	$^{\circ}C$

Functional operation above the stresses listed in the Recommended Operating Ranges is not implied. Extended exposure to stresses beyond the Recommended Operating Ranges limits may affect device reliability.

USER CONFIGURATION

Control Types and Application

STR-ECS640A-GEVB is populated in a way to sample each inverter leg current separately as well as each output voltage and the high voltage DC bus. However, the user may leverage only what is fit for their application requirement and ignore additional data sampled by the remaining AD pins.

Current gain and offset are determined leveraging ECS640A embedded opamp. The outputs of these opamps are directly connected to the AD input pins of ECS640A internal Arm Cortex-M0+ microcontroller (Nebo-40-64). Externally to the ECS640A, these opamp output current signals feed the Overcurrent Protection Circuit. The standard 3-leg current reading circuit is simplified in Figure 4.

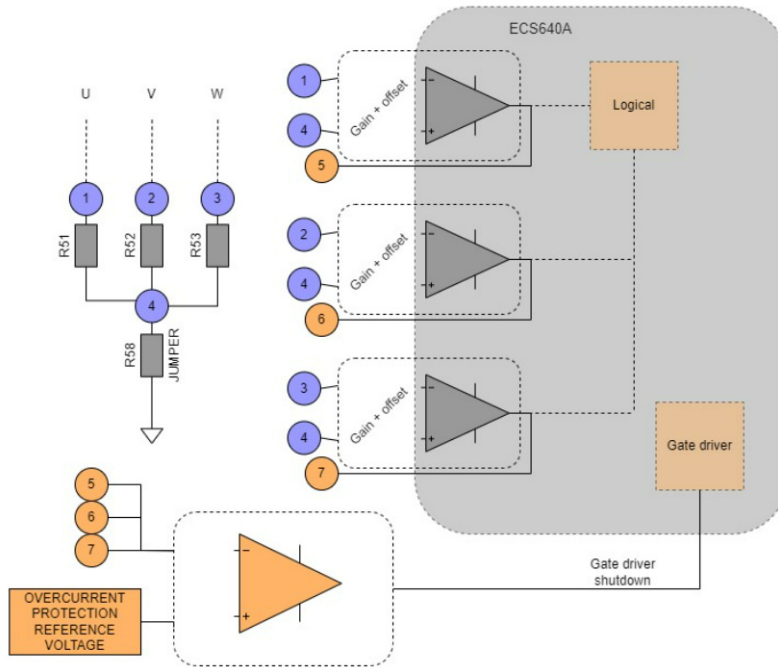

Figure 4. Three-Leg Current Reading Diagram

The user has access to the components that set the shunt values, as well as the gain, offset and the overcurrent protection setpoint, as these circuits are visible in STR-ECS640A-GEVB’s schematic.

WARNING: The user must be aware of the risks of manual operation in replacing electronic parts from this module, which may not have the intended effect due to shorts or cold solder joints as well as several other failure modes that may occur as a consequence of this interaction. The application software must also be updated to reflect the changes in hardware.

STR-ECS640A-GEVB has a dedicated overcurrent circuit for applications that consider the sum of the currents method instead of sensing the current from each inverter leg separately. If single shunt bus overcurrent method is preferred, then shunts topology must be changed and the 4th opamp circuit is available with its own gain and offset provided, as well as a dedicated overcurrent protection setpoint. This case is represented in Figure 5.

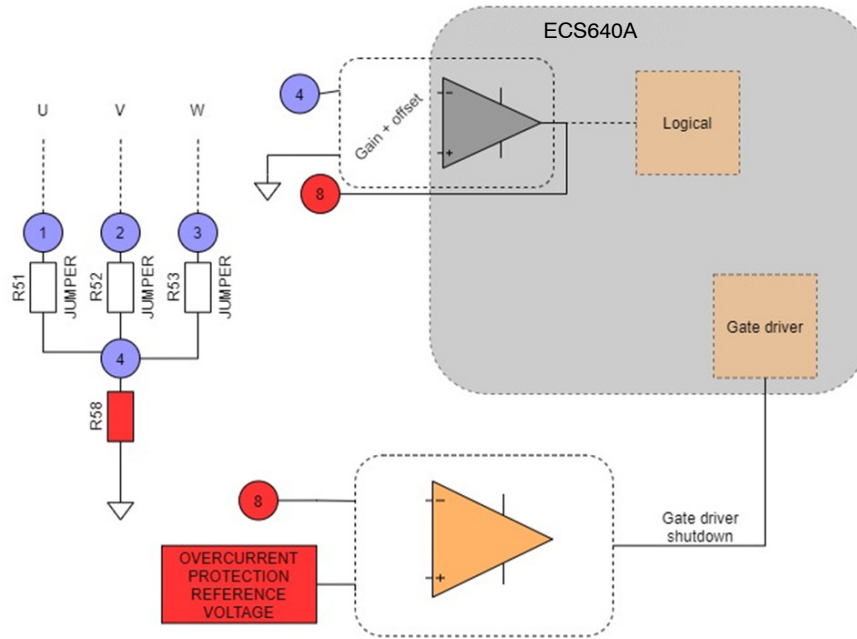

Figure 5. Bus Current Reading Diagram

Voltage Input and Motor Connection

Figure 6 shows the connections for the high voltage non isolated signals that can be attached to the STR-ECS640A-GEVB.

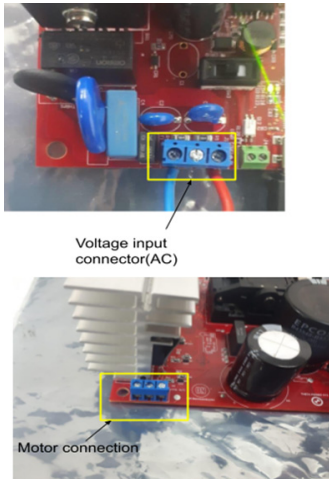

Figure 6. Voltage Input and Motor Connection

AC Rectifier: Voltage Doubler or Full Wave

Voltage doubler topology (120AC input) should have jumper J6 populated and capacitor C3 mounted. Full wave topology (230VA input) should have J6 jumper and C3 capacitor depopulated and a J7 jumper added to C3 footprint location.

WARNING: Do not use voltage doubler topology with 230 VAC input: it will result in serious damage. Figure 7 shows both configurations. When using voltage doubler topology the high voltage DC bus is roughly twice the input peak voltage.

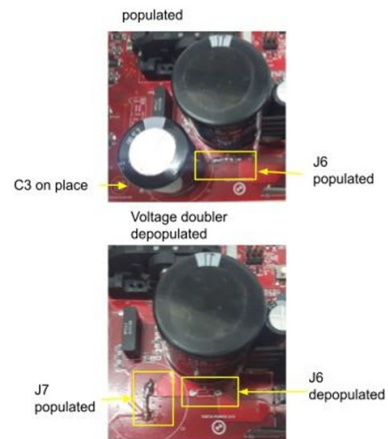

Figure 7. AC Rectifier – 120 V or 230 V Configurations

EVBUM2816/D

GENERAL FEATURES

STR-ECS640A-GEVB has different options and features, which are shown in Figure 9 and specified on Table 2.

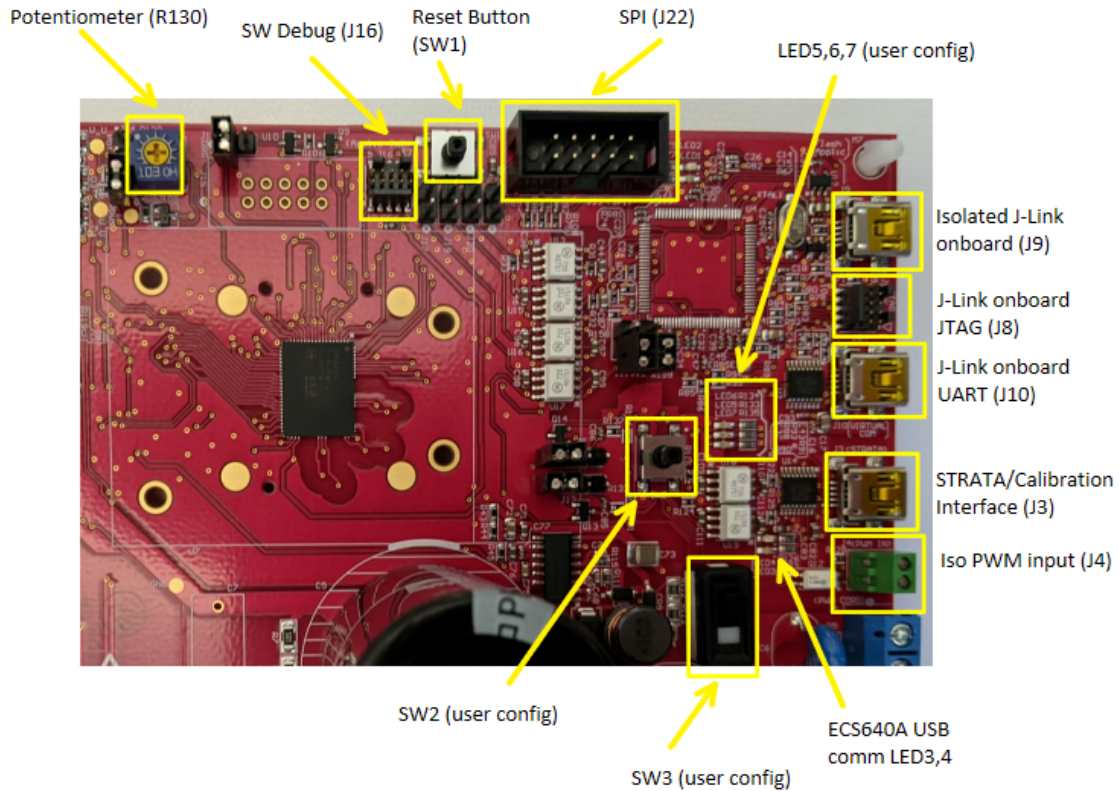

Figure 8. Evaluation Board Features

Table 1.

Component	PCB Designator	Comment / Function
USER INPUT CONFIGURATION		
Potentiometer	R130	Function to be defined by user's custom software
Button	SW2	Function to be defined by user's custom software
Slide switch	SW3	Function to be defined by user's custom software
LED'S CONFIGURATION		
J-link on-board led communication	LED 1, 2	Visual feedback for Jlink operation (flashing, debugging, etc.)
ECS640A USB-UART LED communication	LED 3, 4	Visual feedback for ECS640A J3 USB-UART communication
User interface LEDs	LED 5, 6, 7	Function to be defined by user's custom software
USER'S CONNECTION FOR PROGRAMMING AND DEBUG		
Non-isolated external J-link	J15, J16	Option for external J-link connection
SPI	J22	Optional SPI or Hall sensor connection
Isolated J-link on board	J9	Direct USB connection to flash ECS640A
Program J-link firmware	J8	To update or reset J-link onboard firmware
J-link onboard UART	J10	Function to be defined by user's custom software
ECS640A USB-UART connector	J3	Enabled to work with Strata Development Studio or another user defined feature (e.g. ecoSpin DTFC interface app)
Isolated PWM input	J4	Function to be defined by user's custom software

EVBUM2816/D

Jumper Configuration

Many configurations are available by switching the jumper connections in the STR-ECS640A-GEVB. These configurations are shown in Figure 9 to Figure 12.

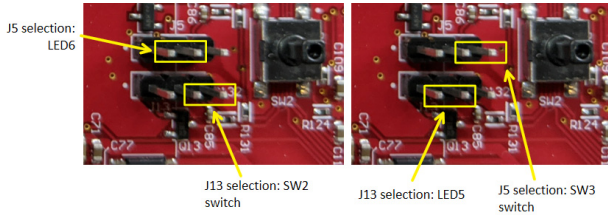

Figure 9. J5 & J13 Jumpers Selection

The STR-ECS640A-GEVB has a NTC thermistor to indirectly monitor the heat sink's temperature, shown in Figure 11.

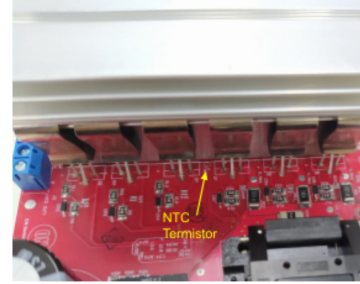

Figure 11. NTC Thermistor Location

The NTC or potentiometer can be selected by changing the connection configuration on J14, as shown in Figure 12.

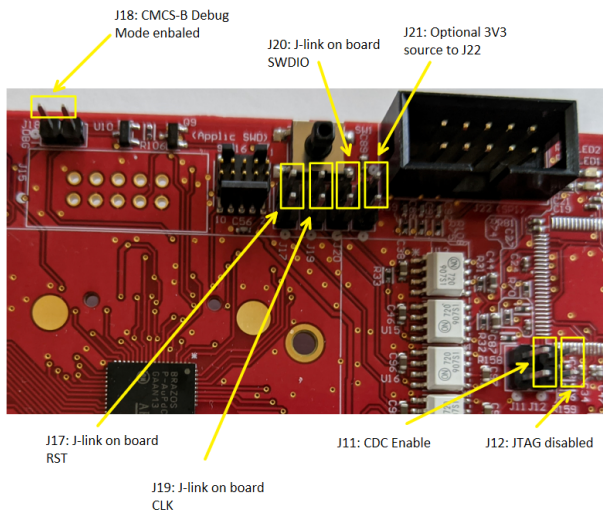

Figure 10. SPI, J-link Onboard, Debug Mode Configuration

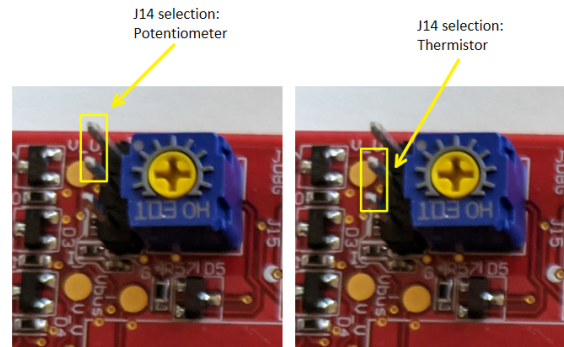

Figure 12. J14 Jumper Selection

Table 2.

Component	PCB Designator	Comment / Function
JUMPER SELECTOR CONFIGURATION		
LED6 or SW3 switch selector	J5	Allows user to manage an extra LED or a switch via custom software
LED5 or SW2 switch selector	J13	Allows user to manage an extra LED or a switch via custom software
Potentiometer or thermistor selector	J14	Allows user to manage an AD input from either the potentiometer or the thermistor
JUMPER ENABLE CONFIGURATION		
SPI VCC configuration	J21	Optional VCC connection to SPI connector to facilitate some debugging tools
UC_SWDIO	J20	If shorted, J-link onboard is used instead of an external tool
UC_CLK	J19	If shorted, J-link onboard is used instead of an external tool
DBG_EN	J18	If shorted, enables ECS640A Nebo debug mode
UC_RST	J17	If shorted, J-link onboard is used instead of an external tool
JTAG Disable	J12	If shorted, J-link onboard disables JTAG
CDC Enable	J11	If shorted, J-link onboard enables CDC

EVBUM2816/D

EVB BILL OF MATERIALS

Item #	Quantity	Description	Designator	Manufacturer	Part Number
1	1	Bridge Rectifiers 8A	BR1	Micro Commercial Co	GBU8K-BP
2	2	Safety Capacitors 2200pF 20% Y5U	C2, C6	Vishay Beyschlag/Draloric/BC	WYO222MCMBF0KR
3	1	CAP ALUM 150UF 20% 450V SNAP	C3	Nichicon	LLS2W151MELZ
4	1	CAP FILM 0.33UF 10% 630VDC RAD	C4	EPCOS - TDK Electronics	B32922C3334K000
5	1	CAP ALUM 330UF 20% 500V SNAP	C5	EPCOS - TDK Electronics	B43548A6337M060
6	1	CAP FILM 0.1UF 10% 630VDC RADIAL	C7	Panasonic Electronic Components	ECW-FE2J104K
7	38	CAP CER 0.1UF 10V X7R 0402	C8, C9, C10, C11, C12, C13, C15, C16, C18, C19, C20, C21, C22, C23, C24, C25, C27, C30, C31, C33, C34, C35, C36, C39, C40, C48, C50, C51, C58, C65, C66, C67, C77, C78, C81, C85, C86, C93	Yageo	CC0402JRX7R6BB104
8	11	CAP CER 10UF 25V X5R 0805	C14, C17, C41, C42, C49, C52, C54, C61, C62, C72, C108	Samsung Electro-Mechanics	CL21A106KAYNNNG
9	1	CAP CER 10PF 50V NP0 0402	C26	Murata Electronics	GCM1555C1H100JA16J
10	2	CAP CER 22PF 50V NP0 0402	C28, C29	Samsung Electro-Mechanics	CL10A105KA8NFNC
11	7	CAP CER 20PF 50V NP0 0402	C32, C37, C43, C47, C53, C55, C56	Yageo	CC0402GRNPO9BN200
12	19	CAP CER 1UF 25V X5R 0603	C38, C44, C46, C57, C63, C71, C76, C82, C83, C87, C89, C96, C97, C98, C99, C109, C110, C111, C112	Samsung Electro-Mechanics	CL10A105KA8NFNC
13	1	CAP CER 10000PF 16V X5R 0402	C45	AVX Corporation	0402YD103KAT2A
14	6	CAP CER 100PF 50V NP0 0402	C59, C84, C88, C90, C91, C92	Murata Electronics	GCM1555C1H101JA16D
15	1	CAP CER 4.7UF 25V X6S 0805	C60	TDK Corporation	C2012X6S1H475K125AC
16	2	CAP CER 0.033UF 25V X7R 0402	C64, C74	TDK Corporation	CGA2B3X7R1H333K050BB
17	1	CAP CER 0.01UF 25V X5R 0603	C68	AVX Corporation	06033D103KAT2A
18	1	CAP CER 0.22UF 35V X5R 0402	C69	Murata Electronics	GRT155R6YA224KE01D
19	1	CAP ALUM 22UF 20% 450V RADIAL	C70	Nichicon	UVY2W220MHD
20	1	CAP CER 47UF 25V X5R 1210	C73	Taiyo Yuden	TMK325ABJ476MM-P
21	1	CAP CER 22UF 10V X5R 0603	C75	Murata Electronics	GRM187R61A226ME15D
22	8	CAP CER 100PF 100V NP0 0603	C79, C94, C95, C101, C102, C104, C105, C107	AVX Corporation	06031A101JAT2A
23	4	CAP CER 20PF 50V NP0 0603	C80, C100, C103, C106	Yageo	CC0603JRNPO9BN200

EVBUM2816/D

EVB BILL OF MATERIALS (continued)

Item #	Quantity	Description	Designator	Manufacturer	Part Number
24	7	DIODE GEN PURP 75V 250MA SOD123	CR1, CR2, CR3, CR4, CR5, CR6, CR7	Micro Commercial Co	1N4448W-TP
25	2	DIODE GEN PURP 600V 1A SOD123F	CR8, CR9	onsemi	ES1JFL
26	1	DIODE GP 600V 3A SMB	CR10	onsemi	S3JB
27	4	DIODE ARRAY 100V 215MA SOT23-3	D1, D3, D4, D5	onsemi	BAV99LT1G
28	4	FUSE BRD MNT 10A 350VAC 72VDC	F1	Bel Fuse Inc.	0697H9100-02
29	1	HEATSINK TO-220 TABS BLACK	HS1	Aavid, Thermal Division of Boyd Corporation	6021BG
30	1	HEATSINK PROFILE 87.5MM	HS3		
31	2	TERM BLK 3POS SIDE ENTRY 5MM PCB	J1, J2	TE Connectivity AMP Connectors	1776244-3
32	3	Mini USB,R/A,SMT,B Type,pbFree	J3, J9, J10	TE Connectivity AMP Connectors	1734035-4
33	1	TERMI-BLOK PCB MOUNT, 90 2P.	J4	TE Connectivity AMP Connectors	282834-2
34	3	CONN HEADER VERT 3POS 2.54MM	J5, J13, J14	Sullins Connector Solutions	PREC003SAAN-RC
35	1	Bridge 0R 10mm	J6	Stackpole Electronics Inc	JW60ZT0R00
36	0	Bridge 0R 10mm	J7	Stackpole Electronics Inc	JW60ZT0R00
37	2	CONN HEADER SMD 10POS 1.27MM	J8, J16	Samtec Inc.	FTSH-105-01-L-DV-K-TR
38	7	CONN HEADER VERT 2POS 2.54MM	J11, J12, J17, J18, J19, J20, J21	Sullins Connector Solutions	PREC002SAAN-RC
39	1	CONN HEADER VERT 10POS 2.54MM	J22	On Shore Technology Inc.	302-S101
40	1	RELAY GEN PURPOSE SPST 10A 12V	K1	Omron Electronics Inc-EMC D	G5Q-1A4 DC12
41	1	FIXED IND 1MH 600MA 1.5 OHM TH	L1	Würth Elektronik	7447471102
42	5	LED GREEN DIFFUSED 0603 SMD	LED1, LED3, LED5, LED6, LED7	Rohm Semiconductor	SML-D13FWT86
43	2	LED RED CLEAR 0603 SMD	LED2, LED4	Lumex Opto/Components Inc	SML-LXFM0603SIC-TR
44	4	SNAP-ON SPACER SCREW MOUNT 9,6 M	M5, M6, M7, M8	Würth Elektronik	709952000
45	5	TRANS PREBIAS NPN 50V SOT23-3	Q1, Q9, Q13, Q14, Q15	onsemi	MMUN2233LT1G
46	6	IGBT 600V 30A 42W TO-220F	Q2, Q3, Q4, Q5, Q6, Q7	onsemi	FGPF15N60UNDF
47	3	OPTOISO 3.75KV TRANS 4-MINI-FLAT	Q10, Q11, Q12	onsemi	FODM8801A
48	1	RES SMD 91 OHM 5% 1/2W 0805	R1	Panasonic Electronic Components	ERJ-P06J910V

EVBUM2816/D

EVB BILL OF MATERIALS (continued)

Item #	Quantity	Description	Designator	Manufacturer	Part Number
49	4	RES SMD 1M OHM 5% 1/4W 1206	R2, R3, R6, R7	Bourns Inc.	CR1206-JW-105ELF
50	2	RES SMD 560K OHM 5% 1/4W 1206	R4, R5	Vishay Dale	CRCW1206560KJNEA
51	12	RES SMD 18 OHM 1% 1/4W 1206	R8, R9, R10, R11, R12, R13, R17, R18, R19, R20, R21, R22	Panasonic Electronic Components	ERJ-8ENF18R0V
52	31	RES SMD 10K OHM 5% 1/10W 0402	R14, R15, R16, R23, R24, R25, R32, R65, R85, R88, R91, R94, R96, R100, R101, R104, R106, R109, R122, R131, R136, R139, R140, R143, R144, R147, R148, R151, R152, R158, R159	Panasonic Electronic Components	ERJ-2GEJ103X
53	15	RES SMD 150K OHM 1% 1/8W 0805	R26, R27, R28, R37, R38, R39, R46, R47, R48, R54, R55, R56, R112, R113, R114	TE Connectivity Passive Product	CRGCQ0805F150K
54	3	RES SMD 330 OHM 1% 1/10W 0402	R29, R40, R49	KOA Speer Electronics, Inc.	RK73H1ETTP3300F
55	7	RES SMD 3.3K OHM 1% 1/10W 0603	R30, R41, R43, R44, R45, R50, R57	Panasonic Electronic Components	ERJ-3EKF3301V
56	6	RES SMD 470 OHM 1% 1/10W 0402	R31, R33, R69, R73, R75, R108	TE Connectivity Passive Product	CRGCQ0402F470R
57	0	Safety Capacitors 2200pF 20% Y5U	C1	Vishay Beyschlag/Draloric/BC	WYO222MCMBF0KR
58	4	RES SMD 100 OHM 1% 1/10W 0603	R34, R35, R36, R42	Samsung Electro-Mechanics	RC1608F101CS
59	3	RES SMD 0.1 OHM 1% 2W 2512	R51, R52, R53	Stackpole Electronics Inc	CSRN2512FTR100
60	1	RES SMD 0.001 OHM 1% 1W 2512	R58	TE Connectivity Passive Product	TLR3A10DR001FTDG
61	2	RES SMD 10.5K OHM 1% 1/10W 0402	R59, R64	Panasonic Electronic Components	ERJ-2RKF1052X
62	3	RES SMD 39K OHM 1% 1/10W 0402	R60, R66, R119	Panasonic Electronic Components	ERJ-U02F3902X
63	5	RES SMD 4.7K OHM 5% 1/10W 0402	R61, R71, R78, R83, R89	Panasonic Electronic Components	RK73B1ETTP472J
64	5	RES SMD 51K OHM 5% 1/10W 0402	R62, R138, R142, R146, R150	Panasonic Electronic Components	ERJ-U02J513X
65	1	RES SMD 10 OHM 5% 1/10W 0402	R63	Panasonic Electronic Components	ERJ-2GEJ100X
66	2	RES SMD 39 OHM 1% 1/10W 0402	R67, R68	Panasonic Electronic Components	ERJ-U02F39R0X
67	4	RES SMD 150 OHM 5% 1/10W 0402	R70, R74, R76, R81	Panasonic Electronic Components	ERJ-2GEJ151X
68	14	RES SMD 100 OHM 5% 1/10W 0402	R72, R80, R84, R86, R87, R90, R92, R93, R95, R97, R99, R102, R107, R120	KOA Speer Electronics, Inc.	RK73B1ETTP101J
69	2	RES SMD 220 OHM 5% 1/10W 0603	R77, R79	Panasonic Electronic Components	ERJ-3GEYJ221V
70	1	RES SMD 6.8K OHM 5% 1/10W 0402	R82	Panasonic Electronic Components	ERJ-2GEJ682X

EVBUM2816/D

EVB BILL OF MATERIALS (continued)

Item #	Quantity	Description	Designator	Manufacturer	Part Number
71	7	RES SMD 1K OHM 5% 1/10W 0402	R98, R103, R105, R110, R129, R132, R137	Panasonic Electronic Components	ERJ-2GEJ102X
72	1	RES SMD 200K OHM 1% 1/10W 0603	R111	Vishay Dale	CRCW0603200KFKEA
73	1	RES SMD 56K OHM 1% 1/10W 0603	R115	Yageo	RC0603FR-0756KL
74	5	RES SMD 2.7K OHM 5% 1/10W 0402	R116, R124, R125, R127, R128	Panasonic Electronic Components	ERJ-2GEJ272X
75	5	RES SMD 2.7K OHM 5% 1/10W 0603	R123, R126, R133, R134, R135	Panasonic Electronic Components	ERJ-3GEYJ272V
76	1	TRIMMER 10K OHM 0.5W PC PIN TOP	R130	Nidec Copal Electronics	CT6ECT-6ER103
77	4	RES SMD 5.1K OHM 1% 1/10W 0402	R141, R145, R149, R153	Panasonic Electronic Components	ERJ-U02F5101X
78	2	SWITCH TACTILE SPST-NO 0.05A 24V	SW1, SW2	Omron Electronics Inc-EMC Div	B3FS-1012
79	1	SWITCH SLIDE SPDT 4A 125V	SW3	APEM Inc.	25139NAH
80	1	ICL 15 OHM 20% 3A 15MM	THRM1	EPCOS - TDK Electronics	B57237S0150M051
81	1	THERMISTOR NTC 15KOHM 3950K 0603	THRM2	Murata Electronics	NCP18XW153J03RB
82	1	Analog Comparators 3-36V Quad Comparator Commercial Temp	U1	onsemi	LM339DR2G
83	2	USB Interface IC USB to Basic Serial UART IC SSOP-16	U2, U14	FTDI	FT230XS-R
84	1	TVS DIODE 5.5VWM SOT143B	U3	Nexperia USA Inc.	PRTR5V0U2X,215
85	1	ARM Microcontrollers - MCU 256K Flash, 52K SRAM 32-bit ARM Cortex M3	U4	Atmel	ATSAM3U2CA-AU
86	4	MMSZ5251BT1G	U5, U6, U8, U9	onsemi	MMSZ5251BT1G
87	1	NFMECS640A0	U7	onsemi	
88	2	BJT SOT-23 45V 800MA	U10, Q8	Diotec Semiconductor	BC807-40
89	1	DUAL OUTPUT HV BUCK SWITCHER 3.3	U11	onsemi	NCP10970A1DR2G
90	1	IC REG LINEAR 3.3V 250MA SOT23-5	U12	onsemi	NCP163ASN330T1G
91	6	OPTOISO 3.75KV PUSH PULL 8SO	U13, U15, U16, U17, U18, U19	onsemi	FOD0720
92	1	VARISTOR 620V 8KA DISC 20MM	V1	EPCOS - TDK Electronic	B72220S0381K101
93	1	CRYSTAL 12.000MHZ 18PF SMD	XTAL1	Abracon LLC	ABLS7M-12.000MHZ-B-2-T

Arm, Cortex, and the Arm logo are registered trademarks of Arm Limited (or its subsidiaries) in the EU and/or elsewhere.
All other brand names and product names appearing in this document are registered trademarks or trademarks of their respective holders.