

STS23 2XXXBXXX

TVS Diode array ESD suppressor

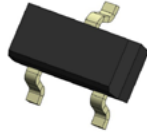

Product features

- 350 Watts peak pulse power per line ($t_p = 8/20 \mu s$)
- Protects two I/O lines with uni-directional
- Low clamping voltage
- Low leakage current
- Meets moisture sensitivity level (MSL) 3
- Molding compound flammability rating: UL 94V-0
- Termination finish: Tin

Applications

- RS-232, RS-422 & RS-485
- Servers, notebook, and desktop
- Cellular handsets and accessories
- Control & monitoring systems
- Portable electronics
- Wireless bus protection
- Set-top box

Environmental compliance and general specifications

- IEC61000-4-2 (ESD)
 - Up to ± 30 kV (air)
 - Up to ± 30 kV (contact)
- IEC61000-4-5 (Lightning) Up to 20 A (8/20 μs)



Ordering part number

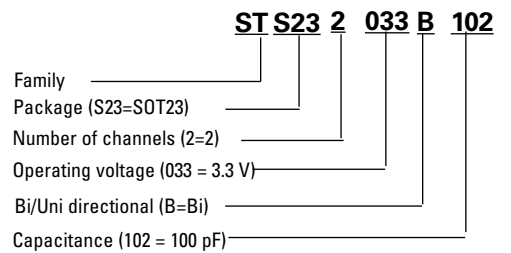

Pin out/functional diagram

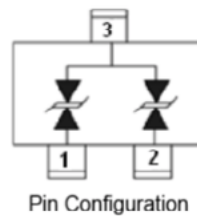
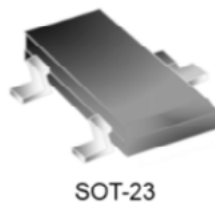

Powering Business Worldwide

Absolute maximum ratings

(+25 °C, RH=45%-75%, unless otherwise noted)

Parameter	Symbol	Value	Unit
		STS232033B102, STS232050B751, STS232120B301, STS232150B251, STS232360B151	STS232240B151
Peak pulse power dissipation on 8/20 μ s waveform	P_{pp}	350	W
ESD per IEC 61000-4-2 (Air)	V_{ESD}	+/-15	kV
ESD per IEC 61000-4-2 (Contact)		+/-8	+/-30
Lead soldering temperature	T_L	+260 (10 seconds)	°C
Operating junction temperature range	T_J	-55 to +125	°C
Storage temperature range	T_{STG}	-55 to +150	°C

Electrical characteristics

(+25 °C)

STS232033B102

Parameter	Test condition	Minimum	Typical	Maximum	Symbol (Units)
Reverse working voltage	-	-	-	3.3	V_{RWM} (V)
Reverse breakdown voltage	$I_r = 1$ mA	3.6	-	-	V_{BR} (V)
Reverse leakage current	$V_{RWM} = 3.3$ V	-	-	1	I_r (μ A)
Clamping voltage	$I_{pp} = 1$ A, $t_p = 8/20$ μ s	-	-	8	V_c (V)
		$I_{pp} = 20$ A, $t_p = 8/20$ μ s	-	-	26
Junction capacitance*	$V_{RWM} = 0$ V, $f = 1$ MHz	-	100	-	C_J (pF)

STS232050B751

Parameter	Test condition	Minimum	Typical	Maximum	Symbol (Units)
Reverse working voltage	-	-	-	5.0	V_{RWM} (V)
Reverse breakdown voltage	$I_r = 1$ mA	5.5	-	-	V_{BR} (V)
Reverse leakage current	$V_{RWM} = 5$ V	-	-	1	I_r (μ A)
Clamping voltage	$I_{pp} = 1$ A, $t_p = 8/20$ μ s	-	-	9.8	V_c (V)
		$I_{pp} = 18$ A, $t_p = 8/20$ μ s	-	-	16.7
Junction capacitance*	$V_{RWM} = 0$ V, $f = 1$ MHz	-	75	-	C_J (pF)

STS232120B301

Parameter	Test condition	Minimum	Typical	Maximum	Symbol (Units)
Reverse working voltage	-	-	-	12	V_{RWM} (V)
Reverse breakdown voltage	$I_T = 1$ mA	13.3	-	-	V_{BR} (V)
Reverse leakage current	$V_{RWM} = 12$ V	-	-	1	I_R (μ A)
Clamping voltage	$I_{pp} = 1$ A, $t_p = 8/20$ μ s	-	-	19	V_C (V)
	$I_{pp} = 12$ A, $t_p = 8/20$ μ s	-	-	25	V_C (V)
Junction capacitance*	$V_{RWM} = 0$ V, $f = 1$ MHz	-	30	-	C_J (pF)

STS232150B251

Parameter	Test condition	Minimum	Typical	Maximum	Symbol (Units)
Reverse working voltage	-	-	-	15	V_{RWM} (V)
Reverse breakdown voltage	$I_T = 1$ mA	16.7	-	-	V_{BR} (V)
Reverse leakage current	$V_{RWM} = 15$ V	-	-	1	I_R (μ A)
Clamping voltage	$I_{pp} = 1$ A, $t_p = 8/20$ μ s	-	-	24	V_C (V)
	$I_{pp} = 10$ A, $t_p = 8/20$ μ s	-	-	35	V_C (V)
Junction capacitance*	$V_{RWM} = 0$ V, $f = 1$ MHz	-	25	-	C_J (pF)

STS232240B151

Parameter	Test condition	Minimum	Typical	Maximum	Symbol (Units)
Reverse working voltage	-	-	-	24	V_{RWM} (V)
Reverse breakdown voltage	$I_T = 1$ mA	26.7	-	-	V_{BR} (V)
Reverse leakage current	$V_{RWM} = 24$ V	-	-	1	I_R (μ A)
Clamping voltage	$I_{pp} = 1$ A, $t_p = 8/20$ μ s	-	-	43	V_C (V)
	$I_{pp} = 6$ A, $t_p = 8/20$ μ s	-	-	60	V_C (V)
Junction capacitance*	$V_{RWM} = 0$ V, $f = 1$ MHz	-	15	-	C_J (pF)

STS232360B151

Parameter	Test condition	Minimum	Typical	Maximum	Symbol (Units)
Reverse working voltage	-	-	-	36	V_{RWM} (V)
Reverse breakdown voltage	$I_T = 1$ mA	40	-	-	V_{BR} (V)
Reverse leakage current	$V_{RWM} = 36$ V	-	-	1	I_R (μ A)
Clamping voltage	$I_{pp} = 1$ A, $t_p = 8/20$ μ s	-	-	60	V_C (V)
	$I_{pp} = 6$ A, $t_p = 8/20$ μ s	-	-	90	V_C (V)
Junction capacitance*	$V_{RWM} = 0$ V, $f = 1$ MHz	-	15	-	C_J (pF)

* C_J measured @ $V_{RWM}=0$ V, $f = 1$ MHz (pin 1 to pin3, pin 2 to pin3)

Mechanical parameters, pad layout- mm/inches

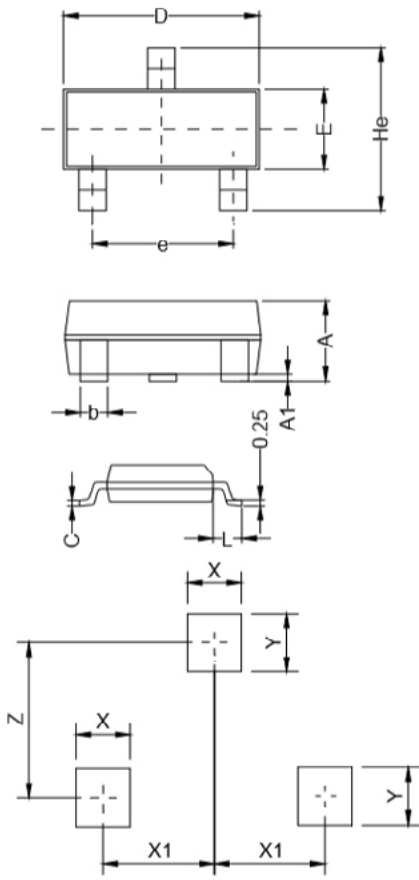

Land Pattern

Dimension	Millimeters		Inches	
	Minimum	Maximum	Minimum	Maximum
A	0.90	1.15	0.035	0.045
A1	0.00	0.10	0.000	0.004
b	0.25	0.325	0.010	0.013
C	0.22	0.25	0.009	0.010
D	2.80	3.00	0.110	0.118
e	1.80	1.90	0.071	0.075
E	1.20	1.40	0.047	0.055
L	0.30	0.50	0.012	0.020
He	2.25	2.55	0.089	0.100
X	0.80 Typ.		0.031 Typ.	
X1	0.95 Typ.		0.037 Typ.	
Y	0.80 Typ.		0.031 Typ.	
Z	2.02 Typ.		0.080 Typ.	

Part marking

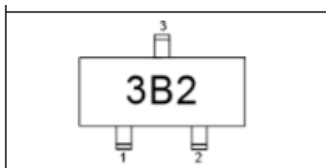

(STS232033B102)

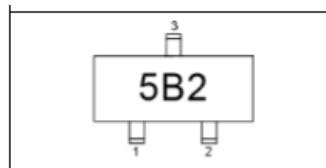

(STS232050B751)

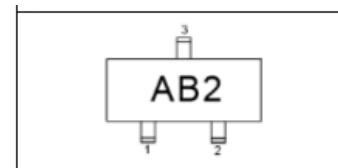

(STS232120B301)

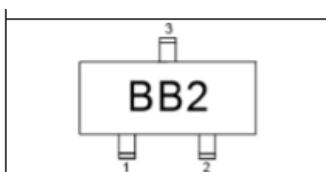

(STS232150B251)

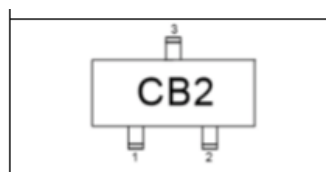

(STS232240B151)

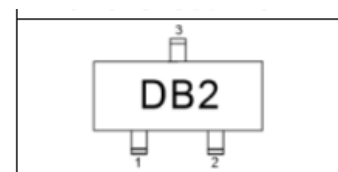

(STS232360B151)

Packaging information mm/inches

Drawing not to scale.

Supplied in tape and reel packaging, 3,000 parts per 7" diameter reel (EIA-481)

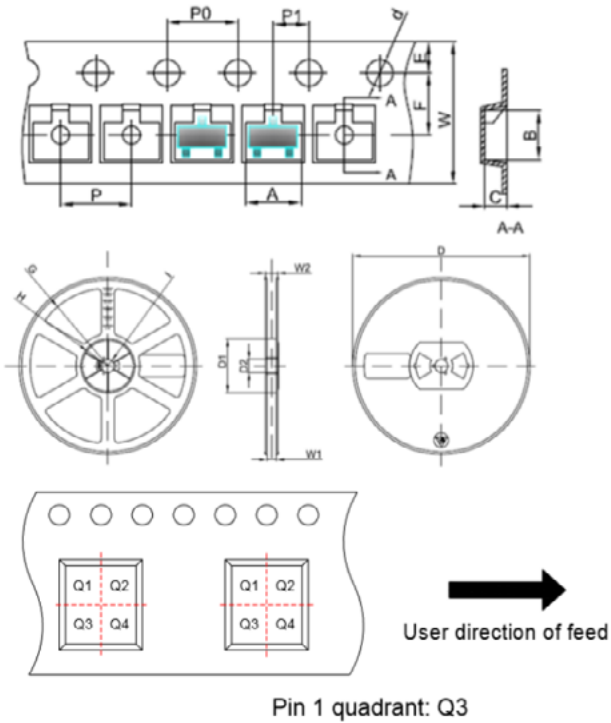

Symbol	Millimeters	Inches
	Typ.	Typ.
A	3.15	0.124
B	2.77	0.109
C	1.22	0.048
d	Φ1.50	Φ0.059
E	1.75	0.069
F	3.50	0.138
P0	4.00	0.157
P	4.00	0.157
P1	2.00	0.079
W	8.00	0.315
D	Φ178	Φ7.008
D1	54.40	2.142
D2	13.00	0.512
G	R78.00	R3.071
H	R25.60	R1.008
I	R6.50	R0.256
W1	9.50	0.374
W2	12.30	0.484

Ratings and V-I characteristic curves (+25 °C unless otherwise noted)

V- I curve characteristics (Bi-directional)

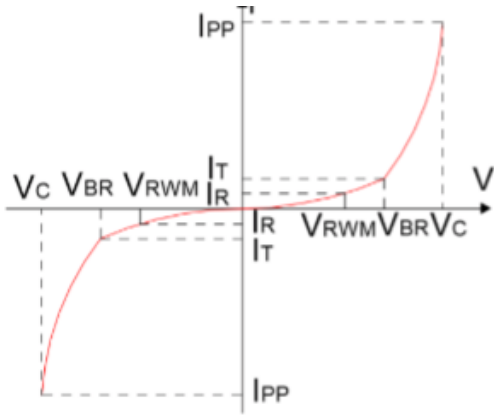

Pulse waveform (8/20 μ s)

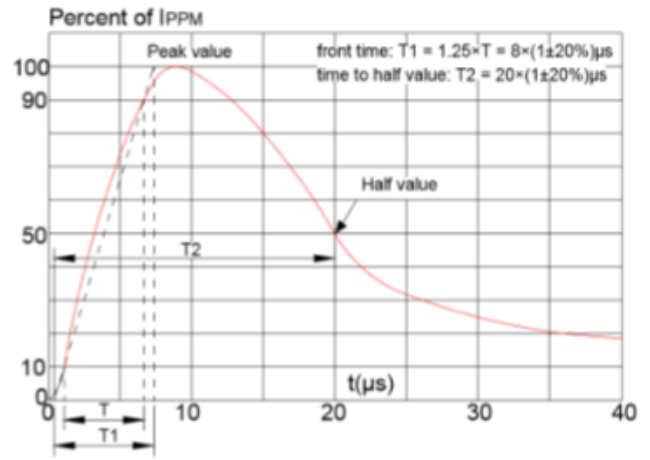

Pulse derating curve

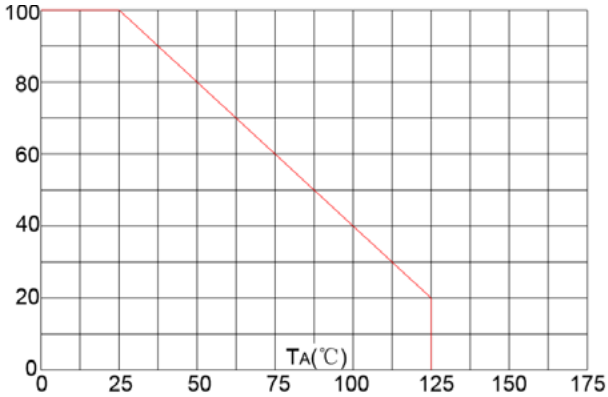

ESD waveform

