

Automotive ultrafast recovery - high voltage diode

Datasheet – production data

Features

- AEC-Q101 qualified
- Ultrafast soft recovery
- Very low conduction and switching losses
- High frequency and/or high pulsed current operation
- High reverse voltage capability
- High junction temperature
- ECOPACK[®]2 compliant component (STTH3010WY)

Description

The high quality design of this diode has produced a device with low leakage current, regularly reproducible characteristics and intrinsic ruggedness. These characteristics make it ideal for heavy duty applications that demand long term reliability like automotive applications.

The improved performance in low leakage current, and therefore thermal runaway guard band, is an immediate competitive advantage for this device.

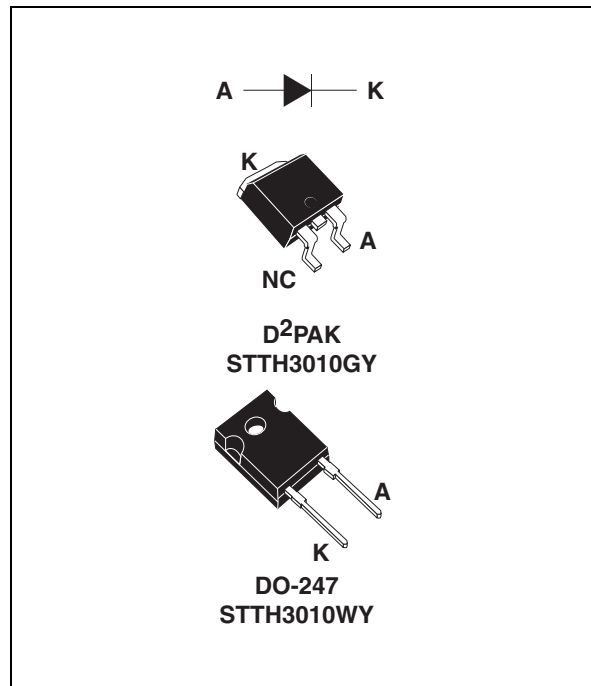

Table 1. Device summary

| | |
|----------------|--------|
| $I_{F(AV)}$ | 30 A |
| V_{RRM} | 1000 V |
| T_j | 175 °C |
| V_F (typ) | 1.30 V |
| t_{rr} (typ) | 42 ns |

1 Characteristics

Table 2. Absolute ratings (limiting values at 25 °C, unless otherwise specified)

| Symbol | Parameter | | Value | Unit |
|--------------|---|---|-------------|------|
| V_{RRM} | Repetitive peak reverse voltage | | 1000 | V |
| $I_{F(RMS)}$ | Forward rms current | | 50 | A |
| $I_{F(AV)}$ | Average forward current, $\delta = 0.5$ | DO-247 | 30 | A |
| | | D ² PAK | | |
| I_{FRM} | Repetitive peak forward current | $t_p = 5 \mu s, F = 5 \text{ kHz square}$ | 300 | A |
| I_{FSM} | Surge non repetitive forward current | $t_p = 10 \text{ ms Sinusoidal}$ | 180 | A |
| T_{stg} | Storage temperature range | | -65 to +175 | °C |
| T_j | Operating junction temperature range | | -40 to +175 | °C |

Table 3. Thermal parameters

| Symbol | Parameter | | Value | Unit |
|---------------|------------------|--------------------|-------|------|
| $R_{th(j-c)}$ | Junction to case | DO-247 | 1.1 | °C/W |
| | | D ² PAK | | |

Table 4. Static electrical characteristics

| Symbol | Parameter | Test conditions | | Min. | Typ | Max. | Unit |
|-------------|-------------------------|------------------------|----------------------|------|-----|------|---------|
| $I_R^{(1)}$ | Reverse leakage current | $T_j = 25 \text{ °C}$ | $V_R = V_{RRM}$ | | | 15 | μA |
| | | $T_j = 125 \text{ °C}$ | | | 10 | 100 | |
| $V_F^{(2)}$ | Forward voltage drop | $T_j = 25 \text{ °C}$ | $I_F = 30 \text{ A}$ | | | 2 | V |
| | | $T_j = 100 \text{ °C}$ | | | 1.4 | 1.8 | |
| | | $T_j = 150 \text{ °C}$ | | | 1.3 | 1.7 | |

1. Pulse test: $t_p = 5 \text{ ms}, \delta < 2\%$
2. Pulse test: $t_p = 380 \mu s, \delta < 2\%$

To evaluate the conduction losses use the following equation:
 $P = 1.3 \times I_{F(AV)} + 0.013 I_{F(RMS)}^2$

Table 5. Dynamic characteristics

| Symbol | Parameter | Test conditions | Min. | Typ | Max. | Unit |
|----------|--------------------------|---|------|-----|------|------|
| t_{rr} | Reverse recovery time | $I_F = 1\text{ A}$, $di_F/dt = -50\text{ A}/\mu\text{s}$, $V_R = 30\text{ V}$, $T_j = 25\text{ }^\circ\text{C}$ | | | 100 | ns |
| | | $I_F = 1\text{ A}$, $di_F/dt = -100\text{ A}/\mu\text{s}$, $V_R = 30\text{ V}$, $T_j = 25\text{ }^\circ\text{C}$ | | 53 | 70 | |
| | | $I_F = 1\text{ A}$, $di_F/dt = -200\text{ A}/\mu\text{s}$, $V_R = 30\text{ V}$, $T_j = 25\text{ }^\circ\text{C}$ | | 42 | 55 | |
| I_{RM} | Reverse recovery current | $I_F = 30\text{ A}$, $di_F/dt = -200\text{ A}/\mu\text{s}$, $V_R = 600\text{ V}$, $T_j = 125\text{ }^\circ\text{C}$ | | 24 | 32 | A |
| S | Softness factor | $I_F = 30\text{ A}$, $di_F/dt = -200\text{ A}/\mu\text{s}$, $V_R = 600\text{ V}$, $T_j = 125\text{ }^\circ\text{C}$ | | 1 | | |
| t_{fr} | Forward recovery time | $I_F = 30\text{ A}$, $di_F/dt = 100\text{ A}/\mu\text{s}$ $V_{FR} = 1.5 \times V_{Fmax}$, $T_j = 25\text{ }^\circ\text{C}$ | | | 450 | ns |
| V_{FP} | Forward recovery voltage | $I_F = 30\text{ A}$, $di_F/dt = 100\text{ A}/\mu\text{s}$, $T_j = 25\text{ }^\circ\text{C}$ | | 5 | | V |

Figure 1. Conduction losses versus average current

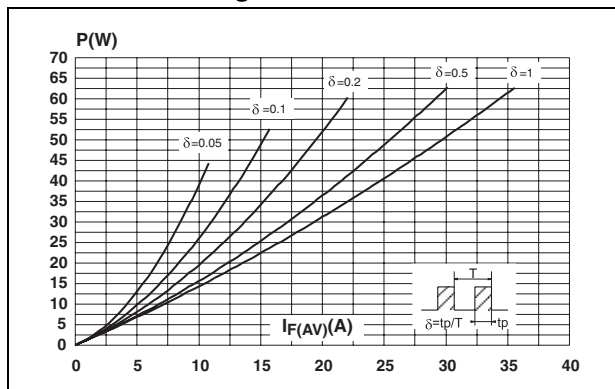

Figure 2. Forward voltage drop versus forward current

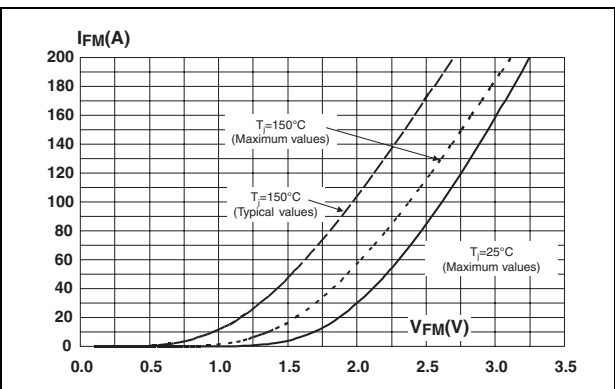

Figure 3. Relative variation of thermal impedance junction to case versus pulse duration

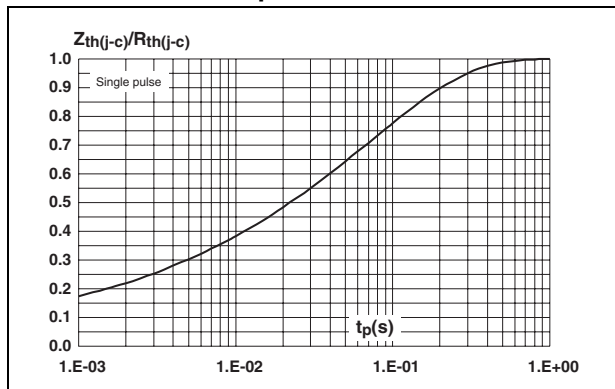

Figure 4. Peak reverse recovery current versus di_F/dt (typical values)

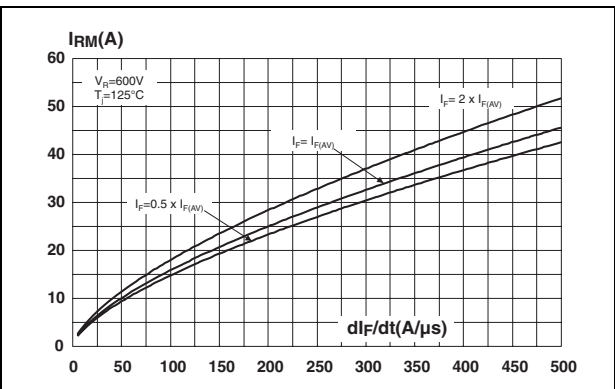

Figure 5. Reverse recovery time versus di_F/dt (typical values)

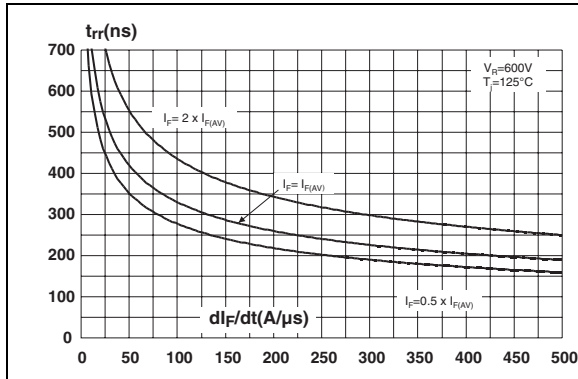

Figure 6. Reverse recovery charges versus di_F/dt (typical values)

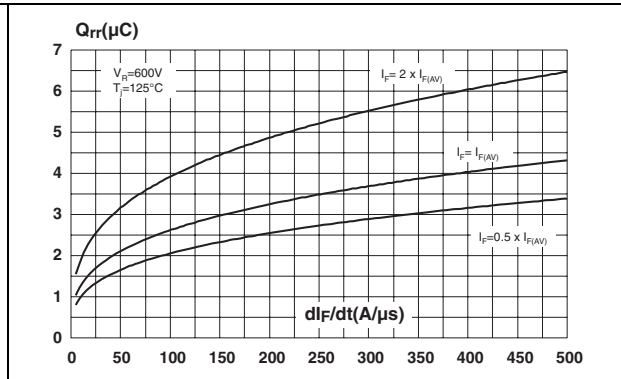

Figure 7. Softness factor versus di_F/dt (typical values)

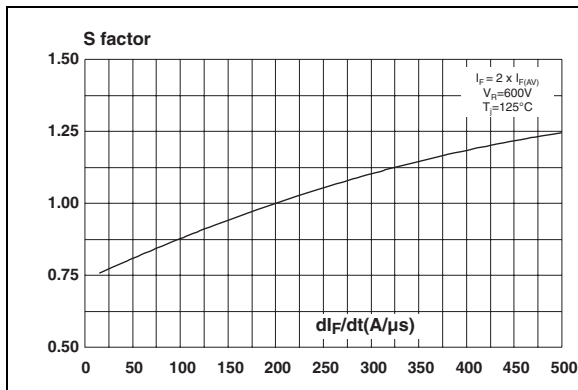

Figure 8. Relative variations of dynamic parameters versus junction temperature

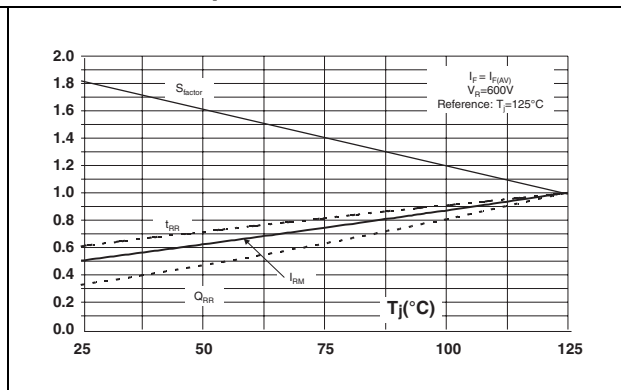

Figure 9. Transient peak forward voltage versus di_F/dt (typical values)

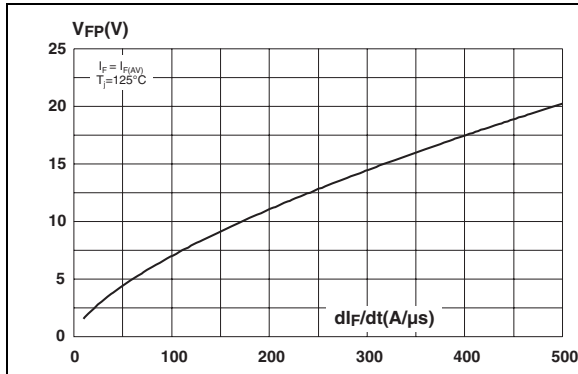

Figure 10. Forward recovery time versus di_F/dt (typical values)

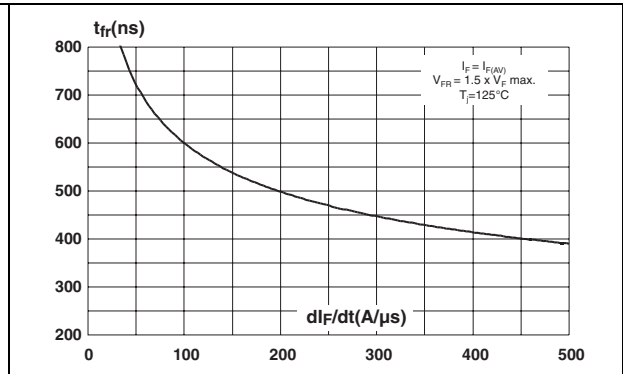
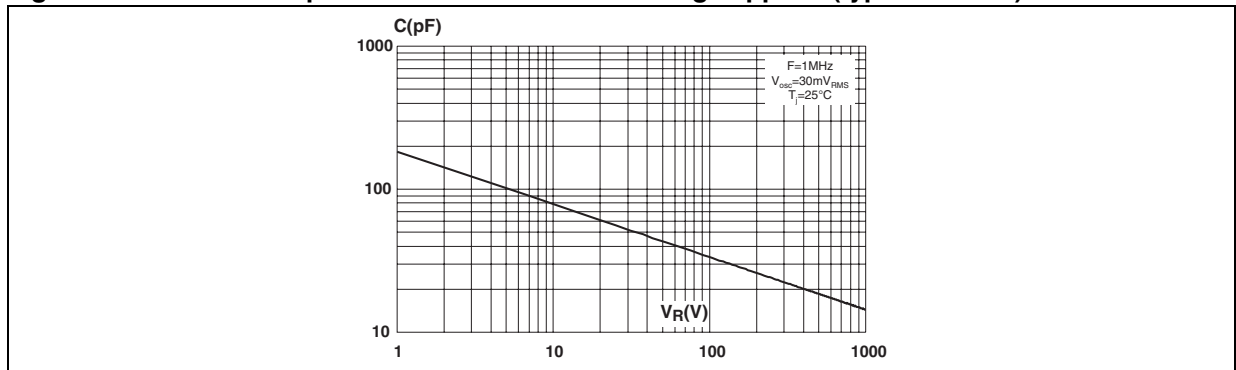

Figure 11. Junction capacitance versus reverse voltage applied (typical values)



2 Package information

- Epoxy meets UL94, V0
- Cooling method: by conduction (C)
- Recommended torque value: 0.80 N·m (DO-247)
- Maximum torque value: 1.0 N·m (DO-247)

In order to meet environmental requirements, ST offers these devices in different grades of ECOPACK® packages, depending on their level of environmental compliance. ECOPACK® specifications, grade definitions and product status are available at: www.st.com. ECOPACK® is an ST trademark.

Table 6. DO-247 dimensions

| Ref. | Dimensions | | | | | |
|------|-------------|-------|-------|--------|-------|-------|
| | Millimeters | | | Inches | | |
| | Min. | | Max | Min. | | Max. |
| A | 4.85 | | 5.15 | 0.191 | | 0.203 |
| D | 2.20 | | 2.60 | 0.086 | | 0.102 |
| E | 0.40 | | 0.80 | 0.015 | | 0.031 |
| F | 1.00 | | 1.40 | 0.039 | | 0.055 |
| F2 | | 2.00 | | | 0.078 | |
| F3 | 2.00 | | 2.40 | 0.078 | | 0.094 |
| G | | 10.90 | | | 0.429 | |
| H | 15.45 | | 15.75 | 0.608 | | 0.620 |
| L | 19.85 | | 20.15 | 0.781 | | 0.793 |
| L1 | 3.70 | | 4.30 | 0.145 | | 0.169 |
| L2 | | 18.50 | | | 0.728 | |
| L3 | 14.20 | | 14.80 | 0.559 | | 0.582 |
| L4 | | 34.60 | | | 1.362 | |
| L5 | | 5.50 | | | 0.216 | |
| M | 2.00 | | 3.00 | 0.078 | | 0.118 |
| V | | 5° | | | 5° | |
| V2 | | 60° | | | 60° | |
| Dia. | 3.55 | | 3.65 | 0.139 | | 0.143 |

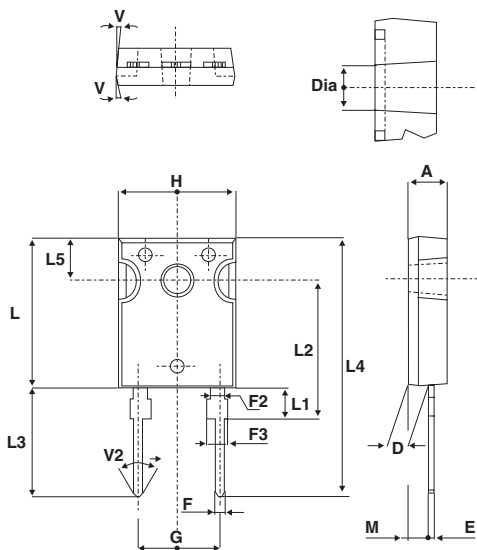
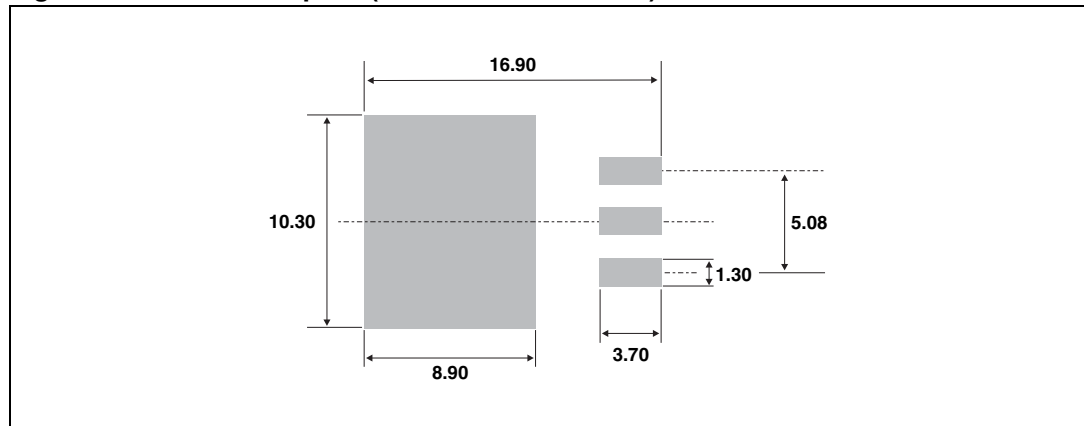

Table 7. D²PAK dimensions

| Ref. | Dimensions | | | |
|------|-------------|-------|------------|-------|
| | Millimeters | | Inches | |
| | Min. | Max | Min. | Max. |
| A | 4.40 | 4.60 | 0.173 | 0.181 |
| A1 | 2.49 | 2.69 | 0.098 | 0.106 |
| A2 | 0.03 | 0.23 | 0.001 | 0.009 |
| B | 0.70 | 0.93 | 0.027 | 0.037 |
| B2 | 1.14 | 1.70 | 0.045 | 0.067 |
| C | 0.45 | 0.60 | 0.017 | 0.024 |
| C2 | 1.23 | 1.36 | 0.048 | 0.054 |
| D | 8.95 | 9.35 | 0.352 | 0.368 |
| E | 10.00 | 10.40 | 0.393 | 0.409 |
| G | 4.88 | 5.28 | 0.192 | 0.208 |
| L | 15.00 | 15.85 | 0.590 | 0.624 |
| L2 | 1.27 | 1.40 | 0.050 | 0.055 |
| L3 | 1.40 | 1.75 | 0.055 | 0.069 |
| M | 2.40 | 3.20 | 0.094 | 0.126 |
| R | 0.40 typ. | | 0.016 typ. | |
| V2 | 0° | 8° | 0° | 8° |

Figure 12. D²PAK footprint (all dimensions in mm)



3 Ordering information

Table 8. Ordering information

| Order code | Marking | Package | Weight | Base qty | Delivery mode |
|---------------|------------|--------------------|--------|----------|---------------|
| STTH3010WY | STTH3010WY | DO-247 | 4.4 g | 30 | Tube |
| STTH3010GY-TR | STTH3010GY | D ² PAK | 1.49 g | 1000 | Tape and reel |

4 Revision history

Table 9. Document revision history

| Date | Revision | Description of Changes |
|-------------|----------|------------------------|
| 28-Jun-2012 | 1 | First issue. |