

Qi-compliant inductive wireless power receiver for 100W applications

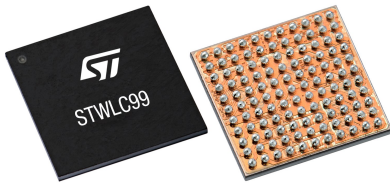

Product status link

[STWLC99](#)

Product summary

Order code	STWLC99JR
Package	WLCSP121
Packing	Tape and reel

Features

- Up to 100W output power
- Up to 25W output power in Tx mode
- Qi 1.2.4 and 1.3 compliant
- Integrated low RDS-ON synchronous rectifier with $\geq 98\%$ efficiency
- ARC(Adaptive Rectifier Configuration) mode for spatial freedom
- Low drop-out linear regulator with output current and input voltage loops
- Programmable output voltage 4V to 20V in steps of 25mV
- 64Mhz 32bit Arm[®] Cortex[®]-M0+ core with 12KB FTP,8KB RAM,48KB ROM
- 11-bit A/D converter
- Configurable GPIO's
- I²C Slave, Master interface
- Watchdog timer
- Multi-levels ASK modulator, Enhanced FSK demodulator
- Accurate current sense system for Foreign Object Detection(FOD)
- Coil Q-factor measurement for FOD in Tx mode
- Over voltage, over current and thermal protections
- Proprietary protocol for power negotiation and authentication
- Suitable for industrial applications, power tools, autonomous robots
- Flip chip 121 bumps (4.859 mm x 4.859 mm)

Application

Application

- Smartphones, Tablets, Laptop
- Cordless power tools
- Power banks

Description

The STWLC99 is a highly integrated wireless power receiver suitable for applications delivering an output power up to 100W. The chip has been designed to support Qi specifications 1.2.4 and 1.3 for inductive communication protocol with Extended Power Profile (EPP) and proprietary ST Super Charge(STSC) protocol for fast charging.

With integrated low-loss synchronous rectifier and low drop-out linear regulator, STWLC99 achieves high efficiency with low power dissipation.

Through I2C interface the user can access and modify the configuration parameters for customized applications, the final configuration parameters are stored in embedded Few Times Programmable(FTP) non-volatile memory and automatically retrieved at power-up.

The device can also operate as wireless transmitter up to 25W (coil dependent)

The device is housed in a Chip-Scale Package to fit real-estate applications with reduced BOM count.

1 Typical Application Diagram

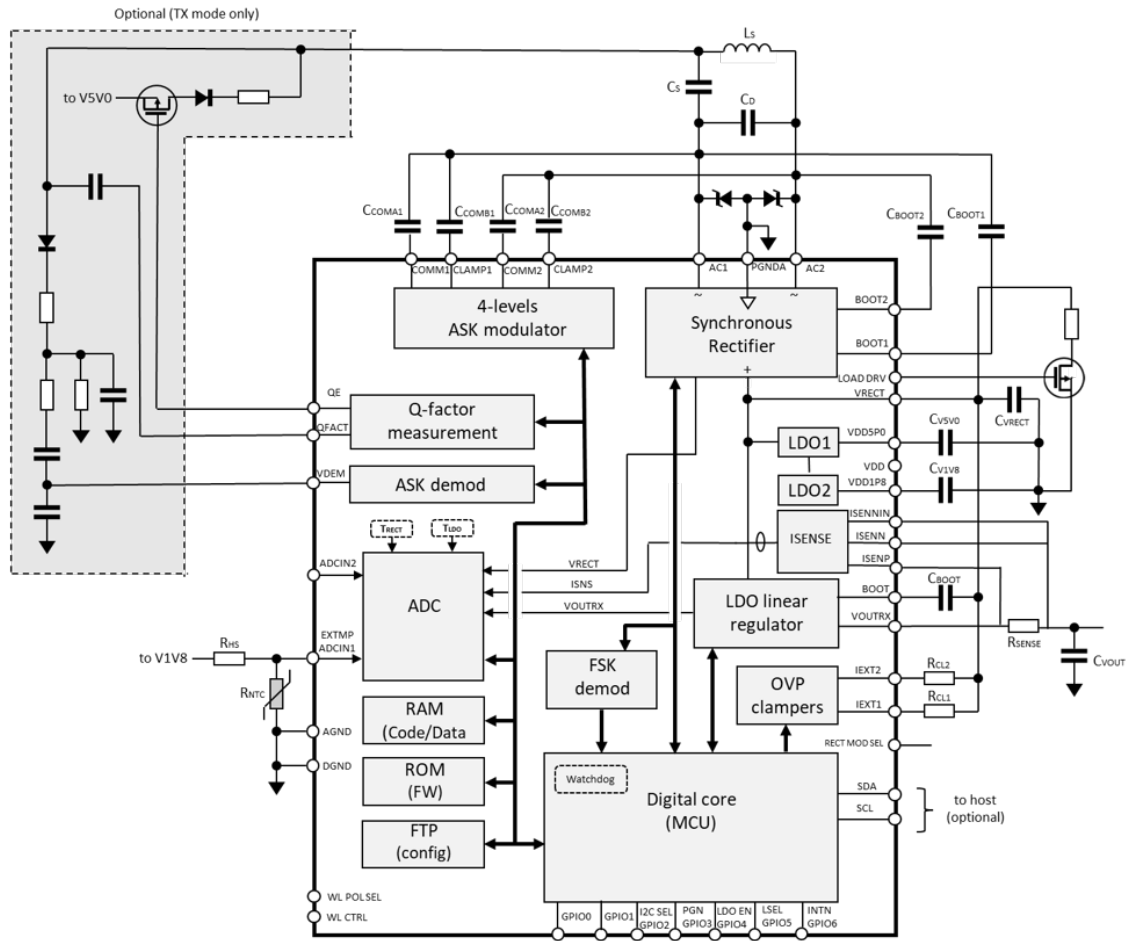

Revision history

Table 1. Document revision history

Date	Version	Changes
10-Oct-2022	1	Initial release.