

## Description

The new power distribution system type SVS24 meets all requirements of the automation technology with regard to reliable overcurrent protection and optimised current distribution. An integral consistent communication of operating and failure conditions as well as switching and resetting of individual circuits of the DC 24 V level via the signalling module SIGMO-24-001 (I/O-Connect) make the SVS24 an intelligent power distribution system on the control level.

The track-mountable power distribution system SVS24-08-001 distributes the voltage potentials supplied by a DC 24 V switch-mode power supply to 8 slots and selectively protects the connected loads by means of the plugged in circuit protector type REF16-S114.

Supply terminals of the DC 24 V supply are spring-loaded terminals and designed for a total current of 40A. Each circuit protector is assigned 3 push-in terminals each for the protected plus load output and for the 0 V load return conductor. The max. load current per channel is 10 A. Three load circuits can be connected directly on the power distribution system so that the 24 V DC control voltage is pre-wired in a space- and cost-saving way. An external loop-in option of e.g. safety switch contacts between the load output terminal (L) and (1) per slot completes the system.

Use of the SIGMO-24-001 (I/O-Connect) allows control of 8 ways via 2 inputs and the compressed signal of all status conditions via an output to a superordinate PLC by means of bit pattern.

### Suitable for the following types:

Electronic circuit protectors **REF16-S114**

## Features

- Systematic integration of overcurrent protection, power distribution and remote input and output
- Power distribution and selective protection of DC 24 V load circuits all in one
- Clear layout of distribution and wiring
- Profitability through considerably reduced wiring time
- Reduction of planning, design and installation time
- Ease of maintenance, diagnosis and system extension
- Compact power distribution for compact control cabinets
- External loop-in option between load output terminal (L) and (1) per slot
- Communication via signalling module



## Technical data ( $T_{amb} = 25\text{ °C}$ , $U_B = \text{DC } 24\text{ V}$ )

### Application

**Modular power distribution system** for short circuit current limited DC 24 V applications

### Supply (X21)

Voltage ratings:	DC 24 V (18 ... 30 V)	
Total current	max. 40 A	
	DC 24 V (+)	= X21 +
	DC 24 V (-)	= X21 -
Terminals	spring-loaded terminals, 1-pole max. cable cross section with/without wire end ferrule 0.25 – 10 mm <sup>2</sup> stripping length 12 mm	

### F-slots

8 ways for circuit protectors,  
prepared for types REF16-S114-...  
F1...F8 = terminals X1...X8

### Load output and minus terminal block per way (X1 ... X8)

Voltage ratings	DC 24 V (18 ... 32 V)
Current	max. 10 A per terminal block X1 ... X8 / slot F1 ... F8 <sup>1)</sup>
Terminals	3 protected load outputs (2/3/4) per slot external loop-in option between load output terminal (L) and (1) per slot

### Caution:

condition as delivered: L and 1 jumpered  
(2) DC 24 V (+)  
(3) DC 24 V (+)  
(4) DC 24 V (+)

3 joint minus return conductors of the load (5/6/7)

(5) DC 24 V (-)  
(6) DC 24 V (-)  
(7) DC 24 V (-)

push-in terminal block, 5-pole / 3-pole  
max. cable cross section  
flexible with wire end ferrule  
(with plastic sleeve) 0.25 – 1.5 mm<sup>2</sup>  
flexible with wire end ferrule  
(without plastic sleeve) 0.25 – 1.5 mm<sup>2</sup>  
stripping length  
with wire end ferrule 8 mm

<sup>1)</sup> When mounted side-by-side and fully equipped with the circuit protectors REF16-Sxxx rated 10A the devices can only carry 80% of their rated load continuously.

## Technical data (T<sub>amb</sub> = 25 °C, U<sub>B</sub> = DC 24 V)

### Control input ( remote and signalling (X41)

Card edge slot (X41) can be fitted variably, see accessories

SIGMO-24-001 I/O connect module, single signalling status and remote input, wiring directly via signal terminals X51

### General data

Mounting of enclosure	symmetrical rail to EN 60715 - 35 x 7.5	
Temperature range	0 ... 50 °C (without condensation)	
Storage temperature	-20 ... +70 °C	
Material of enclosure	plastic material	
Degree of protection	terminals	IP20 DIN 40050
	pcb	IP00 DIN 40050 (double coating)
	SIGMO module	IP00
	Caution: ESD-sensitive sub-assemblies!	
Insulation voltage	DC 250V (pcb)	
Dimensions	see dimensional drawing (tolerances to DIN ISO 286 part 1 IT13)	
Mass	SVS24-08-001	approx. 380 g

## Notes

- The max. total current of 40 A per way must not be exceeded.
- The user has to ensure that the cable cross section of the load circuit in question complies with the current rating of the used load or circuit protector.
- The technical data of the circuit protector have to be observed.
- In addition special precautions must be taken in the system or machine (e.g. use of a safety PLC) which reliably prevent an automatic re-start of parts of the system (cf. Machinery Directive 2006/42/EG and EN 60204-1, Safety of Machinery). In the event of a failure (short circuit/overload) the load circuit will be disconnected by the circuit protector.
- The power distribution system must only be installed by qualified personnel.
- It is only intended for use with safety extra-low voltage (= 24 V DC).
- Only after expert installation must the device be supplied with power.
- After tripping of the circuit protector, before reset, the cause of short circuit or overload has to be remedied.
- The national standards (e.g. for Germany DIN VDE 0100) have to be observed for installation and selection of feed and return cables.
- Connection to a higher or not reliably disconnected voltage can cause hazardous conditions or damages.

## CAUTION



### Caution:

Electrostatically sensitive sub-assemblies can be destroyed by voltages far below the human perception threshold. These voltages already occur if you touch a component or electrical terminals of a sub-assembly without being electrostatically discharged. The damage of a sub-assembly caused by an overvoltage is often not immediately recognised, but will be noticed only after a longer operating time.

## Order numbering code

### Type

**SVS24** power distribution system for REF16-S114 DC24V-xxA

- for short-circuit limited DC 24 V applications
- max. 40 A cont. load
- including jumpers isolated on load output terminal L-1, per slot, plugged in when delivered
- card-edge slot for control input / remote and signalling can optionally be fitted with:
  - signalling module SIGMO-24xxx

### Max. number of circuit protectors on the distribution system

**08** 8 circuit protectors (F1...F8)

### Assembly version, load output / minus terminals

**001** completely fitted with push-in terminals (max. 2.5 mm<sup>2</sup>, without wire end ferrule)

**SVS24 08 -001** ordering example

## Mounting position

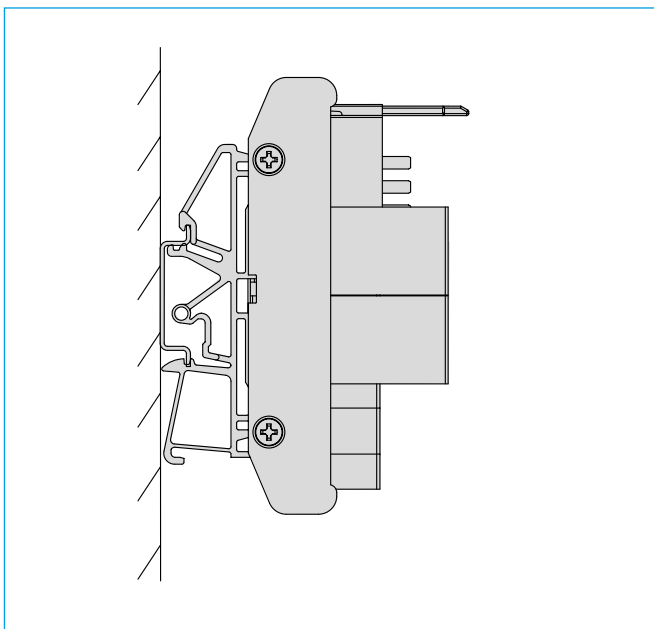

**Schematic diagram SVS24-08-001**

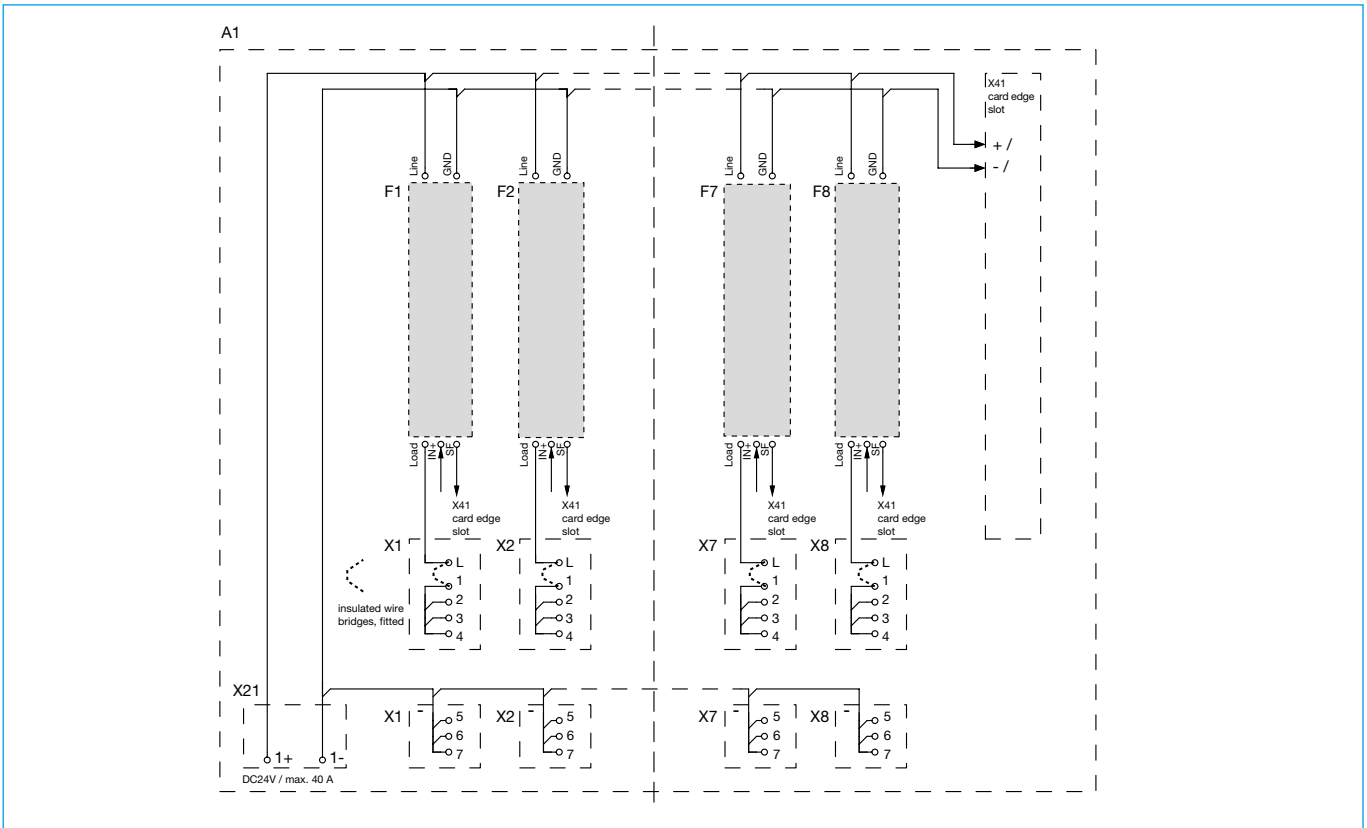

**Dimensions SVS24-08-001**

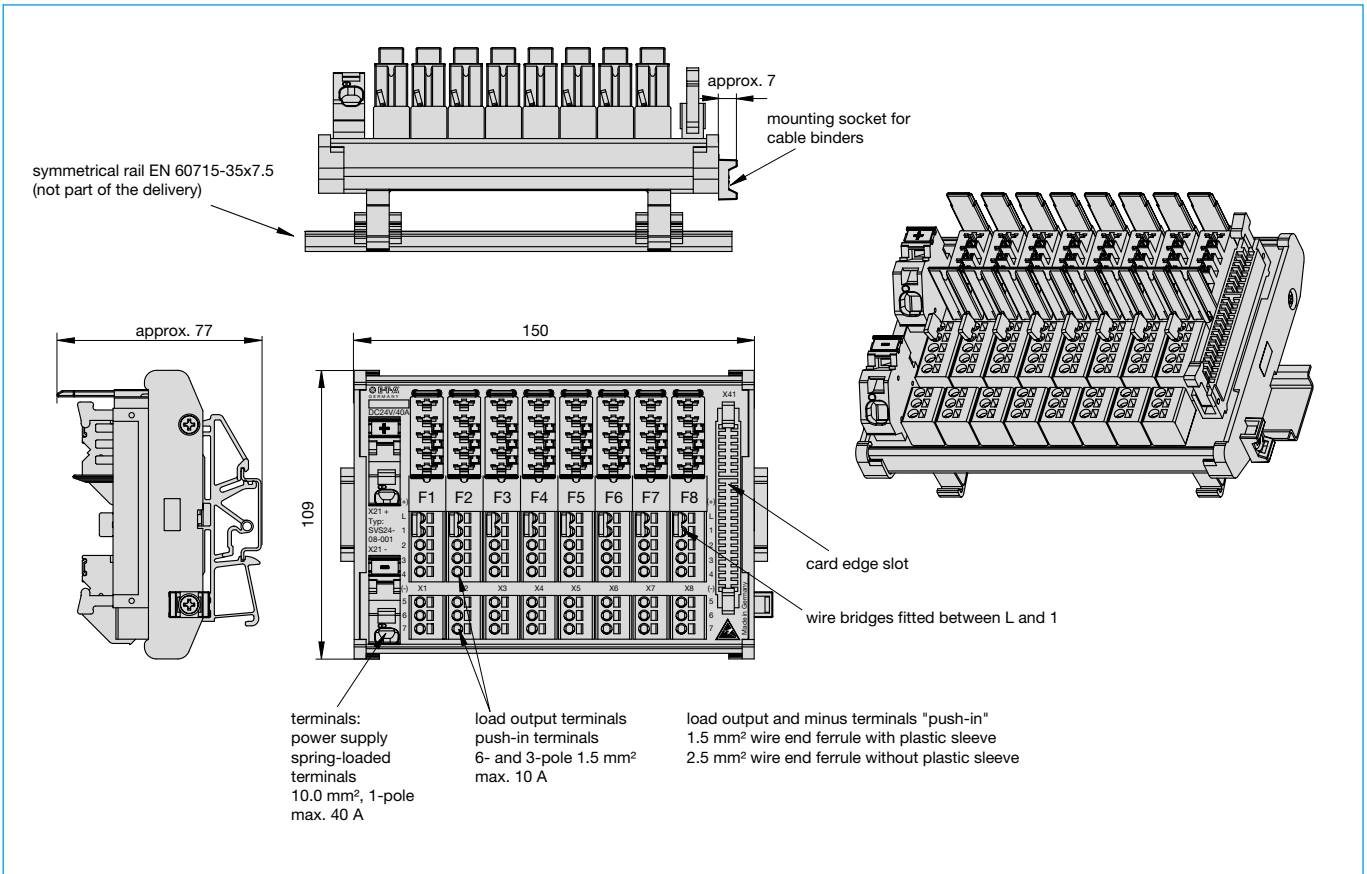

Please order the required population option separately.

**Application example: SVS24-08-001 fitted with REF16-S... and SIGMO-24-001**

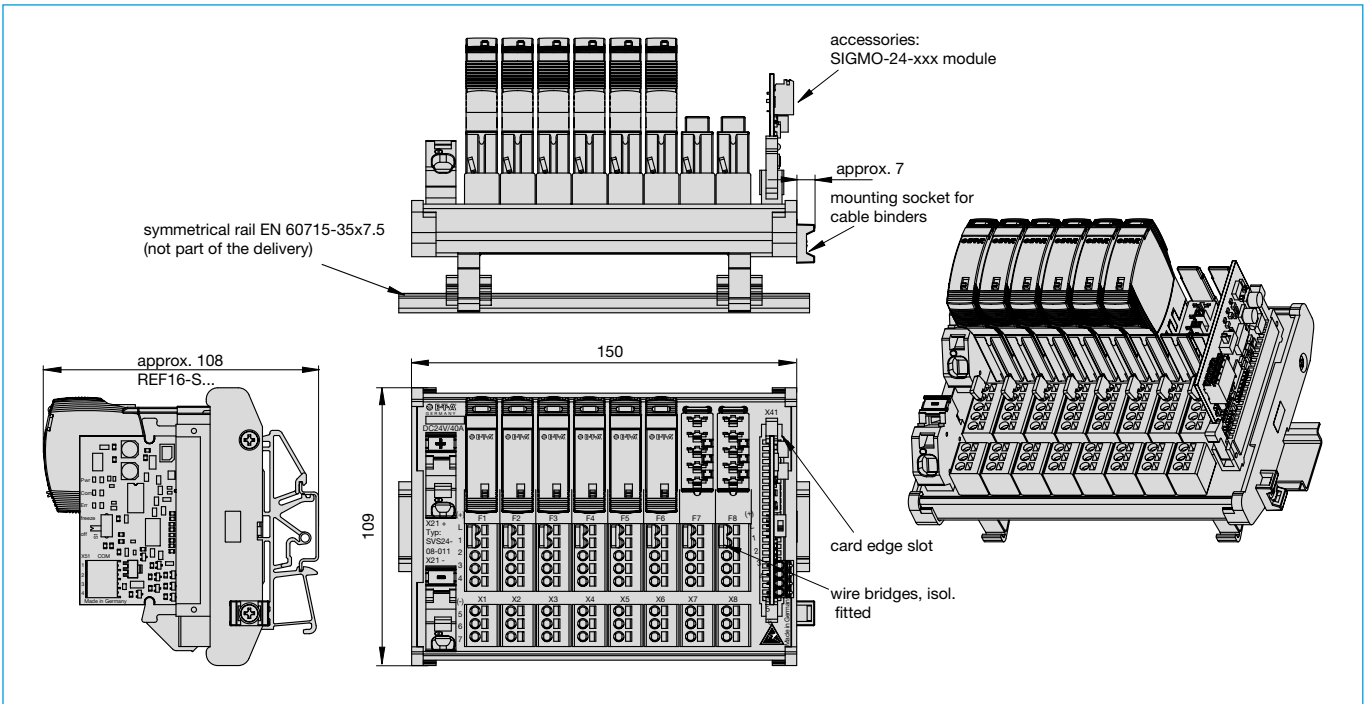

Please order the required population option separately.

**SVS24-08-001, empty**



**SVS24-08-001 fitted with REF16-S... and SIGMO-24-001**

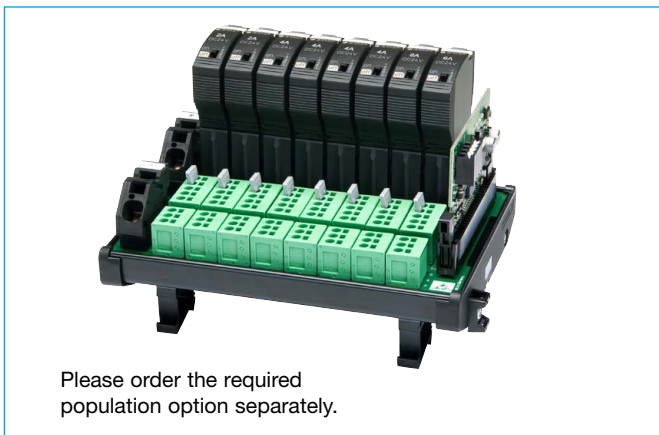

**Accessories**

**6**

**Insulated wire bridge**

**Insulated wire bridge**  
8 pcs of the wire bridge are supplied with the product

**Part no. X 223 108 01**

Packaging unit: 10 pcs

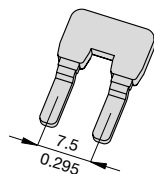

All information and data given on our products are accurate and reliable to the best of our knowledge, but E-T-A does not accept any responsibility for the use in applications which are not in accordance with the present specification. E-T-A reserves the right to change specifications at any time in the interest of improved design, performance and cost effectiveness. Dimensions are subject to change without notice. Please enquire for the latest dimensional drawing with tolerances if required. All dimensions, data, pictures and descriptions are for information only and are not binding. Amendments, errors and omissions excepted. Ordering codes of the products may differ from their marking.