

GaAs SPDT Switch DC - 4 GHz

Rev. V6

Features

- Terminated (SW-226-PIN), High Isolation (SW-227-PIN), Low Loss (SW-228-PIN)
- Fast Switching Speed: 6 nS Typical
- Ultra Low DC Power Consumption
- Lead-Free 7-Lead Ceramic Package
- RoHS* Compliant and 260°C Reflow Compatible

Description

M/A-COM's SW-226/227/228-PIN are GaAs MMIC SPDT switches packaged in lead-free, surface mount CR-2 ceramic style packages. The SW-226-PIN is a terminated SPDT. The SW-227-PIN offers high isolation. The SW-228-PIN offers low insertion loss. This ceramic switch platform has a common footprint for all three designs. The CR-2 package is hermetically sealed, making these switches ideal for space, military radios, and other environmentally harsh applications.

Typical applications include synthesizer switching, transmit/receive switching, switch matrices and filter banks in systems such as radio and cellular equipment, PCM, GPS, and fiber optic modules.

The SW-226/227/228-PIN are fabricated as monolithic GaAs MMICs using a 1.0 micron MESFET process.

Ordering Information

Part Number	Package
SW-226-PIN	Ceramic (CR-2)
SW-227-PIN	Ceramic (CR-2)
SW-228-PIN	Ceramic (CR-2)

Absolute Maximum Ratings ^{1,2}

Parameter	Absolute Maximum
Input Power 0.05 GHz 0.5 - 4.0 GHz	+27 dBm +34 dBm
Control Voltage	-8.5 V ≤ Vc ≤ +5 V
Operating Temperature	-55°C to +125°C
Storage Temperature	-65°C to +150°C

1. Exceeding any one or combination of these limits may cause permanent damage to this device.
2. M/A-COM does not recommend sustained operation near these survivability limits.

Block Diagram/Pin Configuration SW-226-PIN ³

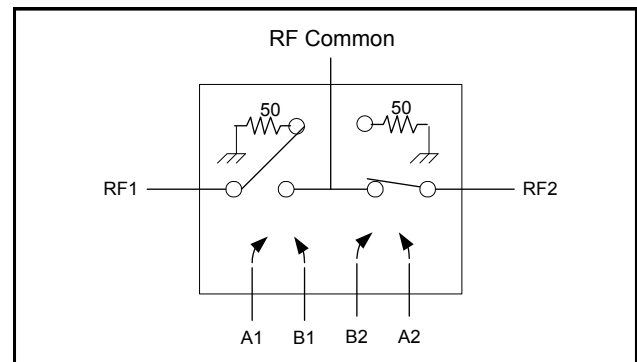

Block Diagram/Pin Configuration SW-227-PIN ³

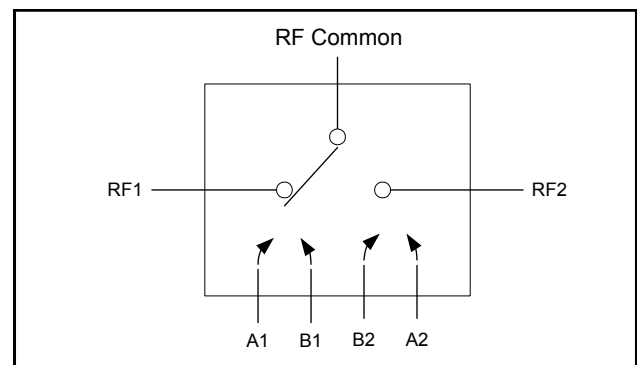

Block Diagram/Pin Configuration SW-228-PIN ³

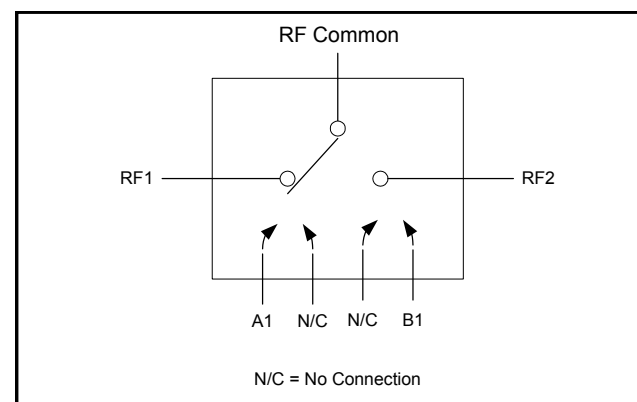

3. Bottom of case is RF ground.

¹ * Restrictions on Hazardous Substances, European Union Directive 2002/95/EC.

M/A-COM Technology Solutions Inc. (MACOM) and its affiliates reserve the right to make changes to the product(s) or information contained herein without notice. Visit www.macom.com for additional data sheets and product information.

Electrical Specifications: $T_A = -55^{\circ}\text{C}$ to $+85^{\circ}\text{C}$, $V_c = 0\text{ V} / -5\text{ V}$, $Z_0 = 50\ \Omega$ ⁴

Parameter	Test Conditions	Units	Min.	Typ.	Max.
Insertion Loss (SW-226-PIN)	DC - 0.5 GHz	dB	—	—	0.9
	DC - 1 GHz	dB	—	—	1.0
	DC - 2 GHz	dB	—	—	1.2
	DC - 4 GHz	dB	—	—	1.5
Insertion Loss (SW-227-PIN)	DC - 0.5 GHz	dB	—	—	0.9
	DC - 1 GHz	dB	—	—	1.0
	DC - 2 GHz	dB	—	—	1.1
	DC - 4 GHz	dB	—	—	1.4
Insertion Loss (SW-228-PIN)	DC - 0.5 GHz	dB	—	—	0.7
	DC - 1 GHz	dB	—	—	0.7
	DC - 2 GHz	dB	—	—	0.8
	DC - 4 GHz	dB	—	—	1.0
Isolation (SW-226-PIN)	DC - 0.5 GHz	dB	53	—	—
	DC - 1 GHz	dB	48	—	—
	DC - 2 GHz	dB	40	—	—
	DC - 4 GHz	dB	25	—	—
Isolation (SW-227-PIN)	DC - 0.5 GHz	dB	55	—	—
	DC - 1 GHz	dB	50	—	—
	DC - 2 GHz	dB	40	—	—
	DC - 4 GHz	dB	35	—	—
Isolation (SW-228-PIN)	DC - 0.5 GHz	dB	50	—	—
	DC - 1 GHz	dB	42	—	—
	DC - 2 GHz	dB	32	—	—
	DC - 4 GHz	dB	22	—	—
VSWR (SW-226-PIN)	DC - 0.5 GHz	Ratio	—	—	1.2:1
	DC - 1 GHz	Ratio	—	—	1.4:1
	DC - 2 GHz	Ratio	—	—	1.6:1
	DC - 4 GHz	Ratio	—	—	2.3:1
VSWR (SW-227-PIN)	DC - 0.5 GHz	Ratio	—	—	1.2:1
	DC - 1 GHz	Ratio	—	—	1.4:1
	DC - 2 GHz	Ratio	—	—	1.6:1
	DC - 4 GHz	Ratio	—	—	2.0:1
VSWR (SW-228-PIN)	DC - 0.5 GHz	Ratio	—	—	1.2:1
	DC - 1 GHz	Ratio	—	—	1.2:1
	DC - 2 GHz	Ratio	—	—	1.3:1
	DC - 4 GHz	Ratio	—	—	1.9:1
Trise, Tfall ⁵	10% to 90% RF, 90% to 10% RF	nS	—	3	—
Ton, Toff ⁵	50% control to 90% RF, 50% control to 10% RF	nS	—	6	—
Transients ⁵ (SW-226-PIN,SW-227-PIN)	In-Band	mV	—	30	—
Transients ⁵ (SW-228-PIN)	In-Band	mV	—	10	—

4. See MIL-STD-883 for environmental screening options.

5. Faster switching speed can be achieved with enhanced driver waveform.

Electrical Specifications (continued): $T_A = -55^{\circ}\text{C}$ to $+85^{\circ}\text{C}$, $V_c = 0\text{ V} / -5\text{ V}$, $Z_0 = 50\ \Omega$

Parameter	Test Conditions	Units	Min.	Typ.	Max.
Input P1dB	0.5 - 4 GHz, 0 / -5 VDC	dBm	—	27	—
	0.05 GHz, 0 / -5 VDC	dBm	—	21	—
	0.5 - 4 GHz, 0 / -8 VDC	dBm	—	33	—
	0.05 GHz, 0 / -8 VDC	dBm	—	26	—
IP2	For two-tone input power up to +13 dBm				
	0.5 - 4 GHz	dBm	—	68	—
IP3	For two-tone input power up to +13 dBm				
	0.5 - 4 GHz	dBm	—	46	—
Control Current	$ V_c = 5\text{ V}$ (SW-226-PIN, SW-227-PIN)	$ V_c = 0$ to 0.2 V	μA	—	20
		$ V_c = 8\text{ V}$ (SW-226-PIN, SW-227-PIN)	μA	—	110
Control Current	$ V_c = 5\text{ V}$ (SW-228-PIN)	$ V_c = 8\text{ V}$ (SW-228-PIN)	μA	—	600
		$ V_c = 5\text{ V}$ (SW-228-PIN)	μA	—	50
Control Current	$ V_c = 8\text{ V}$ (SW-228-PIN)	$ V_c = 5\text{ V}$ (SW-228-PIN)	μA	—	300
		$ V_c = 8\text{ V}$ (SW-228-PIN)	μA	—	—

Handling Procedures

Please observe the following precautions to avoid damage:

Static Sensitivity

Gallium Arsenide Integrated Circuits are sensitive to electrostatic discharge (ESD) and can be damaged by static electricity. Proper ESD control techniques should be used when handling these devices.

SW-226-PIN and SW-227-PIN Truth Table ^{6,7}

Control Input				Condition of Switch, RF Common to each RF Port	
A1	B1	A2	B2	RF1	RF2
1	0	0	1	ON	OFF
0	1	1	0	OFF	ON

SW-228-PIN Truth Table ^{6,7}

Control Input		Condition of Switch, RF Common to each RF Port	
A1	B1	RF1	RF2
1	0	ON	OFF
0	1	OFF	ON

6. 0 = 0 V to -0.2 V, 1 = -5 V to -8 V

7. For the SW-227-PIN and SW-228-PIN only, when an RF output is "OFF" it is shorted to case ground.

SW-226/227/228– PIN



GaAs SPDT Switch
DC - 4 GHz

Rev. V6

Typical Performance Curves

Insertion Loss

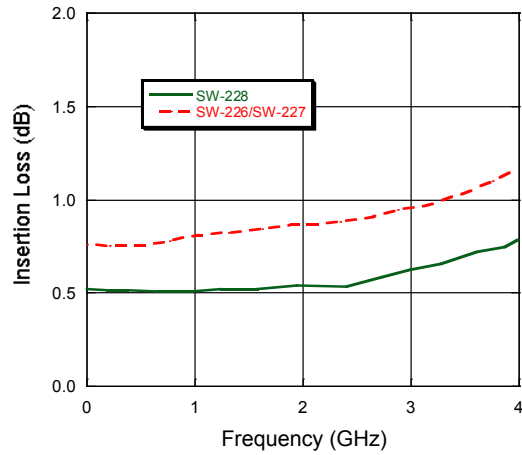

Isolation

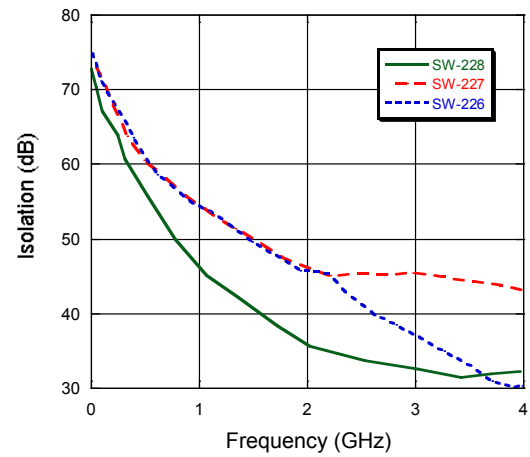

VSWR

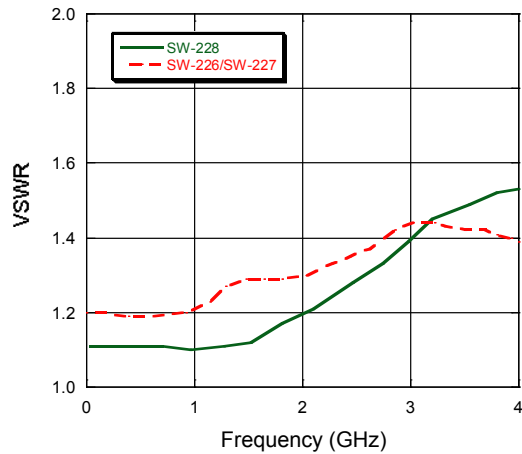

Lead-Free CR-2[†]

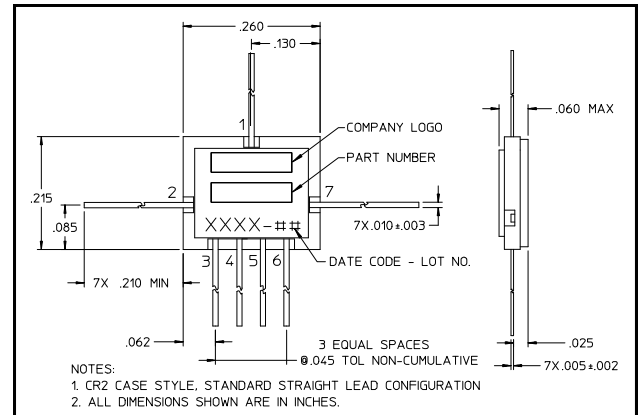

[†] Reference Application Note M538 for lead-free solder reflow recommendations.