



TAOGLAS®



Datasheet

SWLP.2450.12.4.B.02

Description:

12*12*4mm 2.4GHz Wi-Fi SMD Patch Antenna

Features:

2.4 - 2.5GHz Wi-Fi Patch Antenna

For Wi-Fi/WLAN/ISM/Zigbee Industrial Applications

High Gain 2dBi

RoHS & Reach Compliant

1.	Introduction	3
2.	Specifications	4
3.	Antenna Characteristics	5
4.	2D Radiation Patterns	7
5.	3D Radiation Patterns	10
6.	Mechanical Drawing	12
7.	Antenna Integration Guide	13
8.	Mechanical Drawing - Evaluation Board	19
9.	Packaging	19
	Changelog	20

Taoglas makes no warranties based on the accuracy or completeness of the contents of this document and reserves the right to make changes to specifications and product descriptions at any time without notice. Taoglas reserves all rights to this document and the information contained herein. Reproduction, use or disclosure to third parties without express permission is strictly prohibited.



1. Introduction



This 12*12*4mm high gain 2.4GHz patch antenna is ideally suited for high performance industrial applications in the 2.4GHz Wi-Fi, ISM, and Zigbee bands. This product has highest gain at broadside, most suitable for fixed wireless applications where transmission and reception is focused to one hemisphere of the device, for example a wireless meter on a reinforced concrete wall. It can also be placed anywhere on the device ground-plane, unlike most chip or loop antennas which need to be edge mounted.

Many module manufacturers specify peak gain limits for any antennas that are to be connected to that module. Those peak gain limits are based on free-space conditions. In practice, the peak gain of an antenna tested in free space can degrade by at least 1 or 2dBi when put inside a device. So ideally you should go for a slightly higher peak gain antenna than mentioned on the module specification to compensate for this effect, giving you better performance.

Upon testing of any of our antennas with your device and a selection of appropriate layout, integration technique, or cable, Taoglas can make sure any of our antennas' peak gain will be below the peak gain limits. Taoglas can then issue a specification and/or report for the selected antenna in your device that will clearly show it complying with the peak gain limits, so you can be assured you are meeting regulatory requirements for that module.

For example, a module manufacturer may state that the antenna must have less than 2dBi peak gain, but you don't need to select an embedded antenna that has a peak gain of less than 2dBi in free space. This will give you a less optimized solution. It is better to go for a slightly higher free-space peak gain of 3dBi or more if available. Once that antenna gets integrated into your device, performance will degrade below this 2dBi peak gain due to the effects of GND plane, surrounding components, and device housing. If you want to be absolutely sure, contact Taoglas and we will test. Choosing a Taoglas antenna with a higher peak gain than what is specified by the module manufacturer and enlisting our help will ensure you are getting the best performance possible without exceeding the peak gain limits.

2. Specifications

Electrical	
Frequency Range	2400~2500MHz
Bandwidth	100MHz @ -7dB
Efficiency	80.12% @ Centre Freq. 2450MHz
Polarization	Linear
VSWR	3.0 max @ Centre Freq. 2450MHz
Peak Gain	+2dBi typ.
Impedance	50Ω
Mechanical	
Dimensions	12*12*4mm
Weight	4g
Environmental	
Operating Temperature	-40°C to +85°C
Storage Temperature	-40°C to +85°C
Termination	Ag (Environmentally Friendly Pb Free)
Moisture Sensitivity Level (MSL)	3 (168 Hours)

3. Antenna Characteristics

3.1 Return Loss

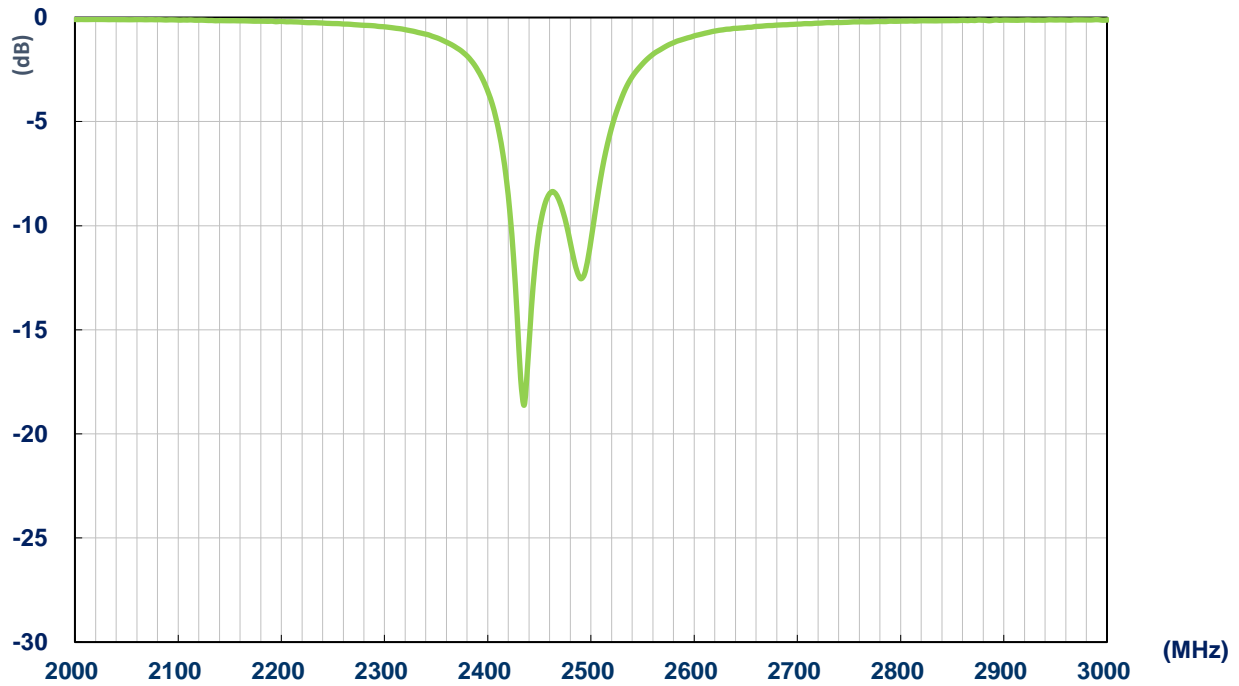

3.2 Efficiency

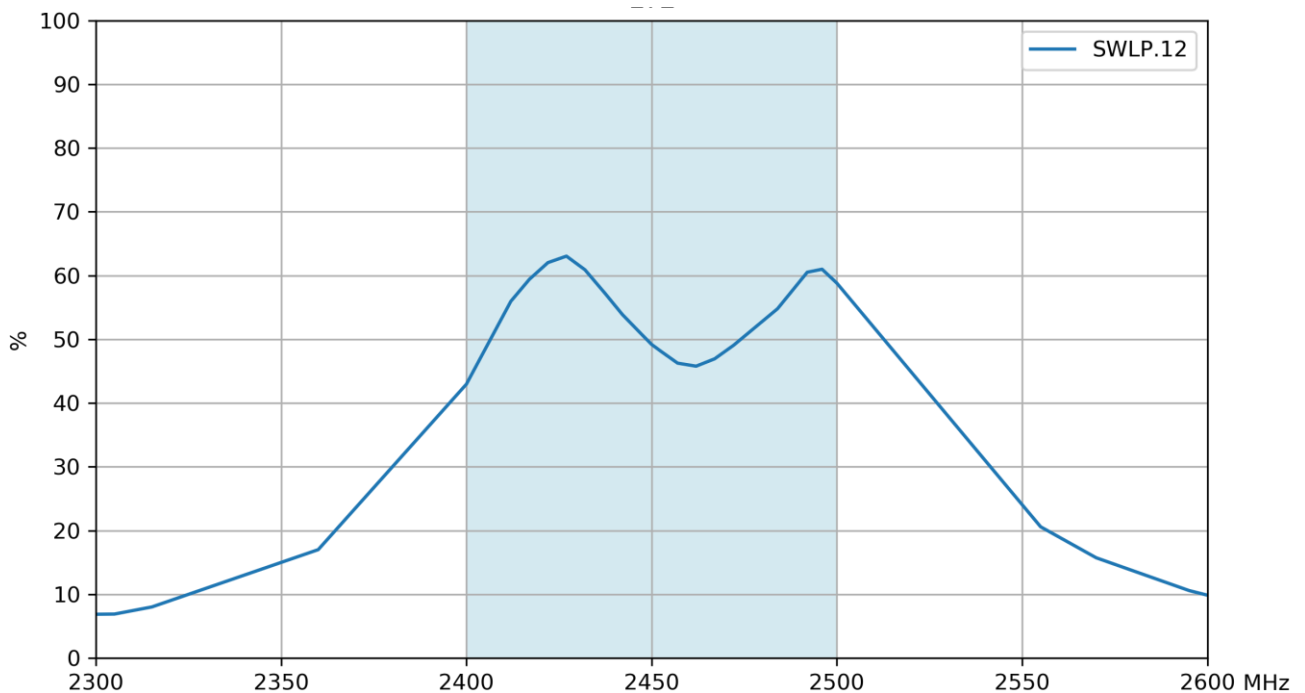

3.3 Average Gain

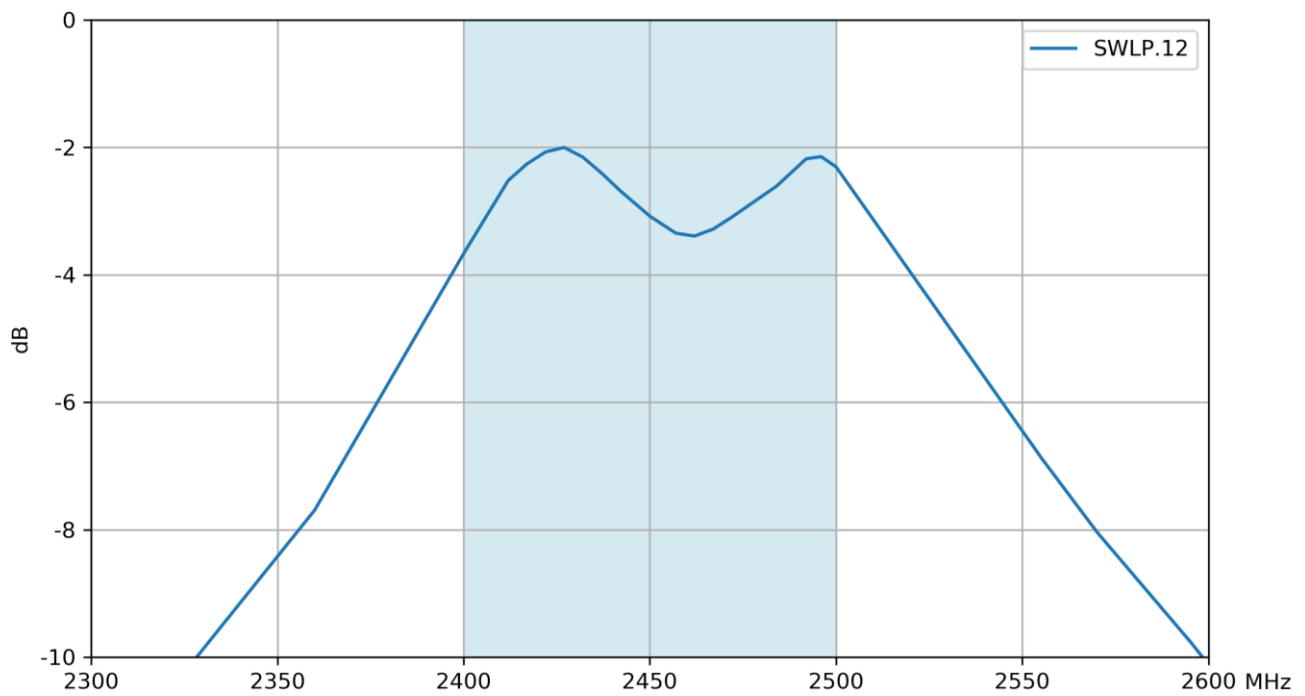

3.4 Peak Gain

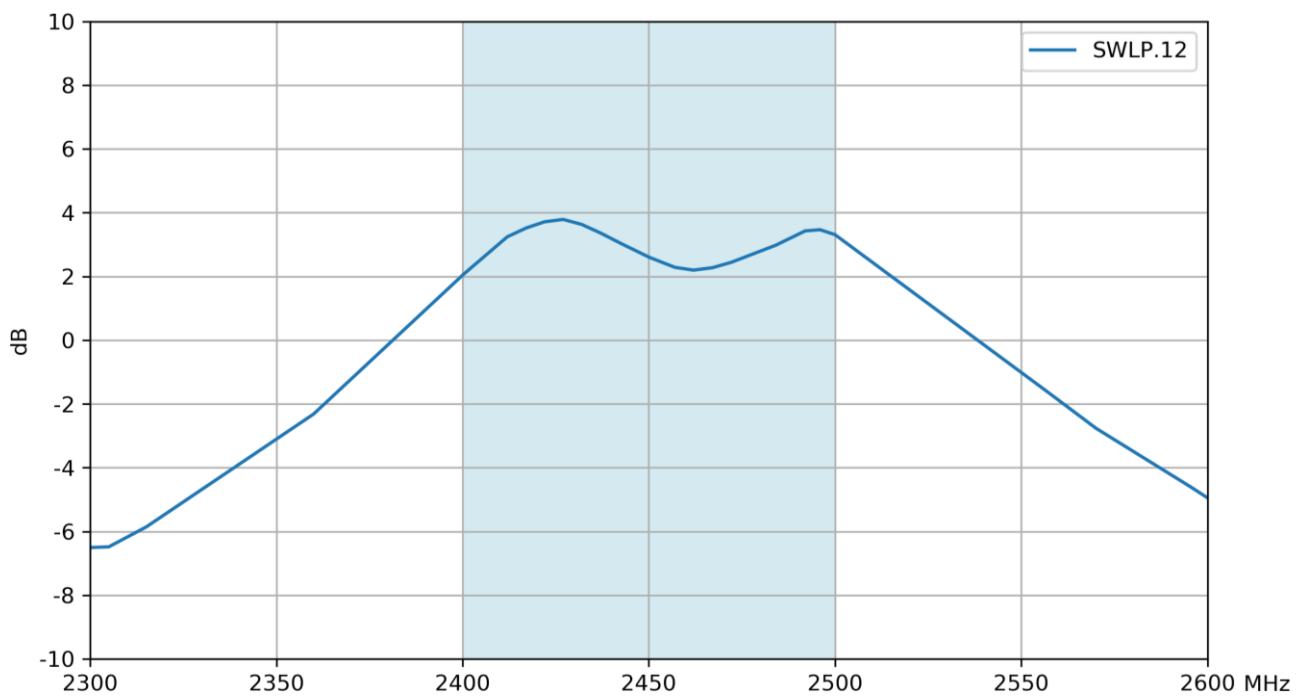

4. 2D Radiation Patterns

4.1 Test Setup

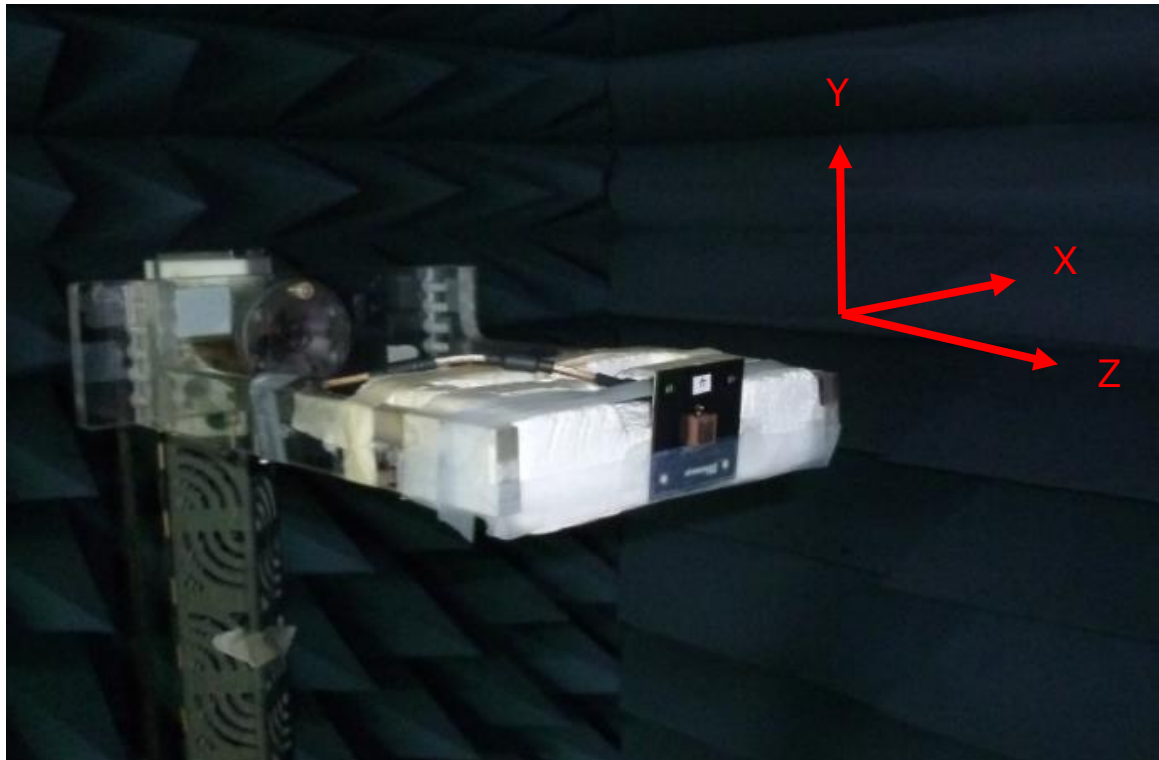

On Evaluation Board

XY Plane

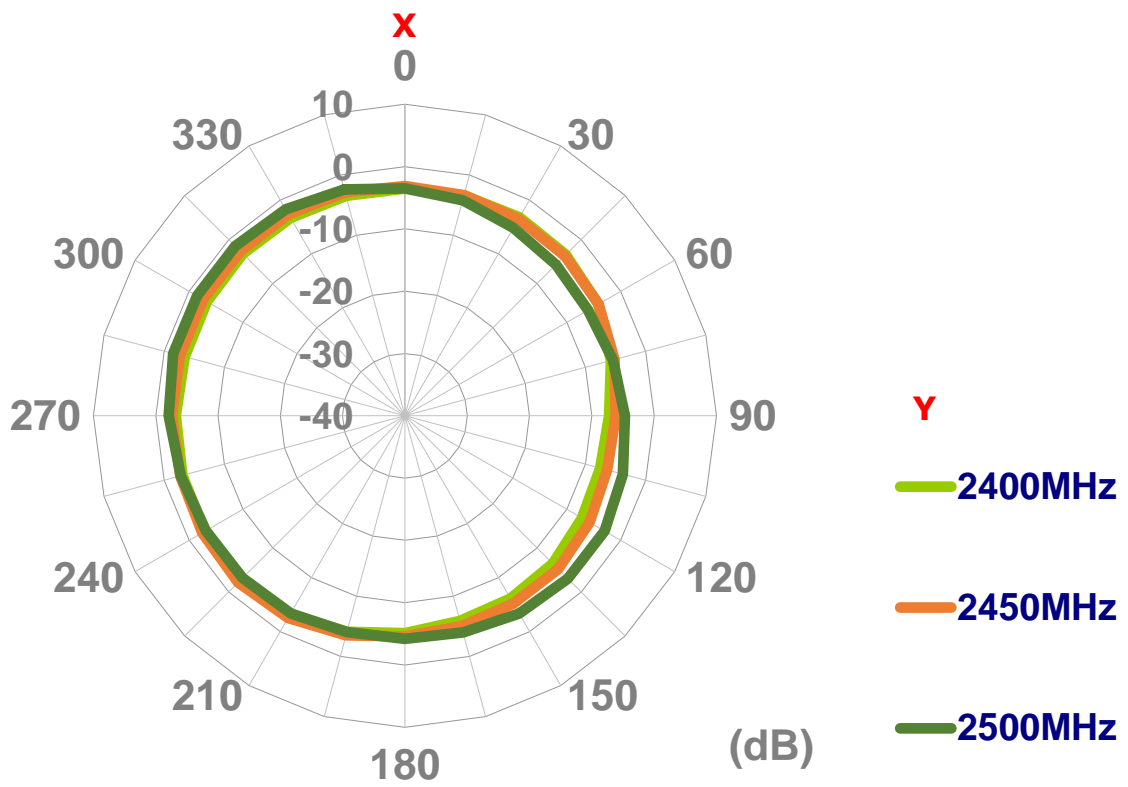

XZ Plane

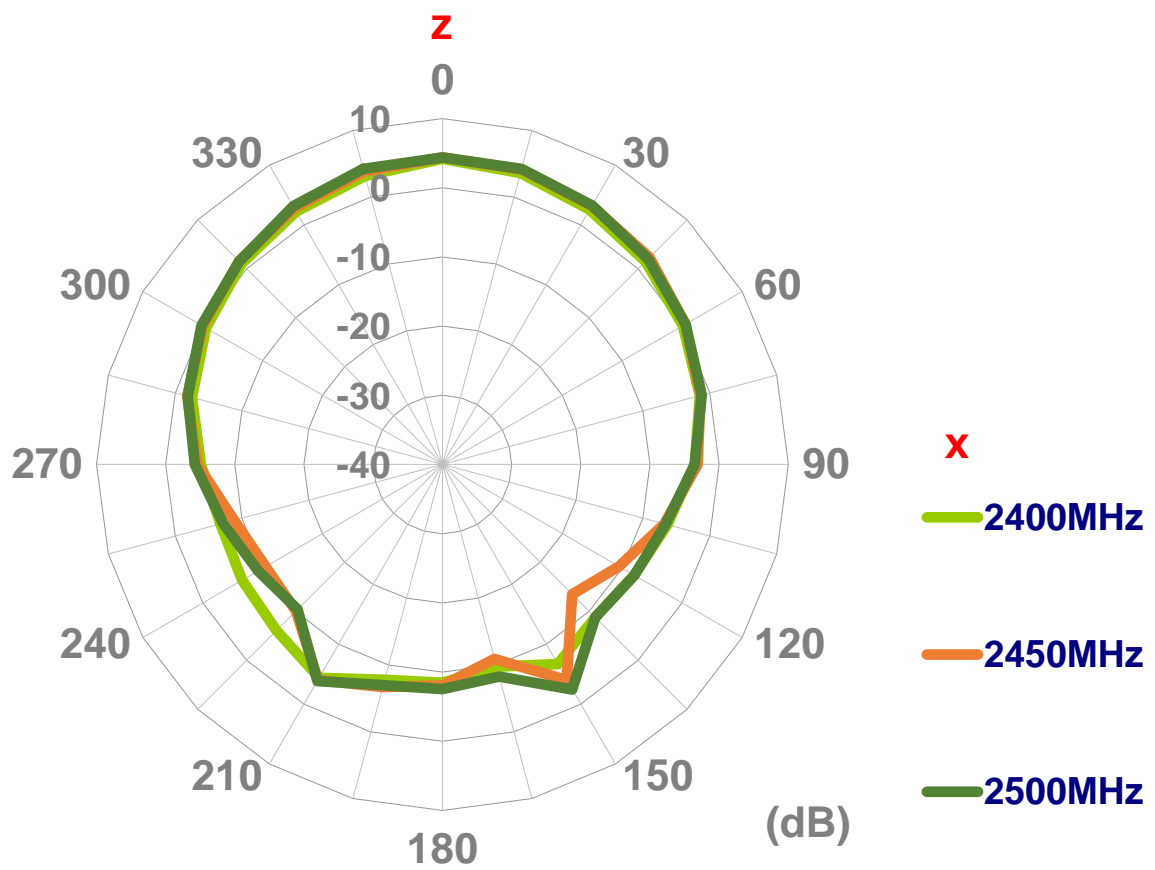

YZ Plane

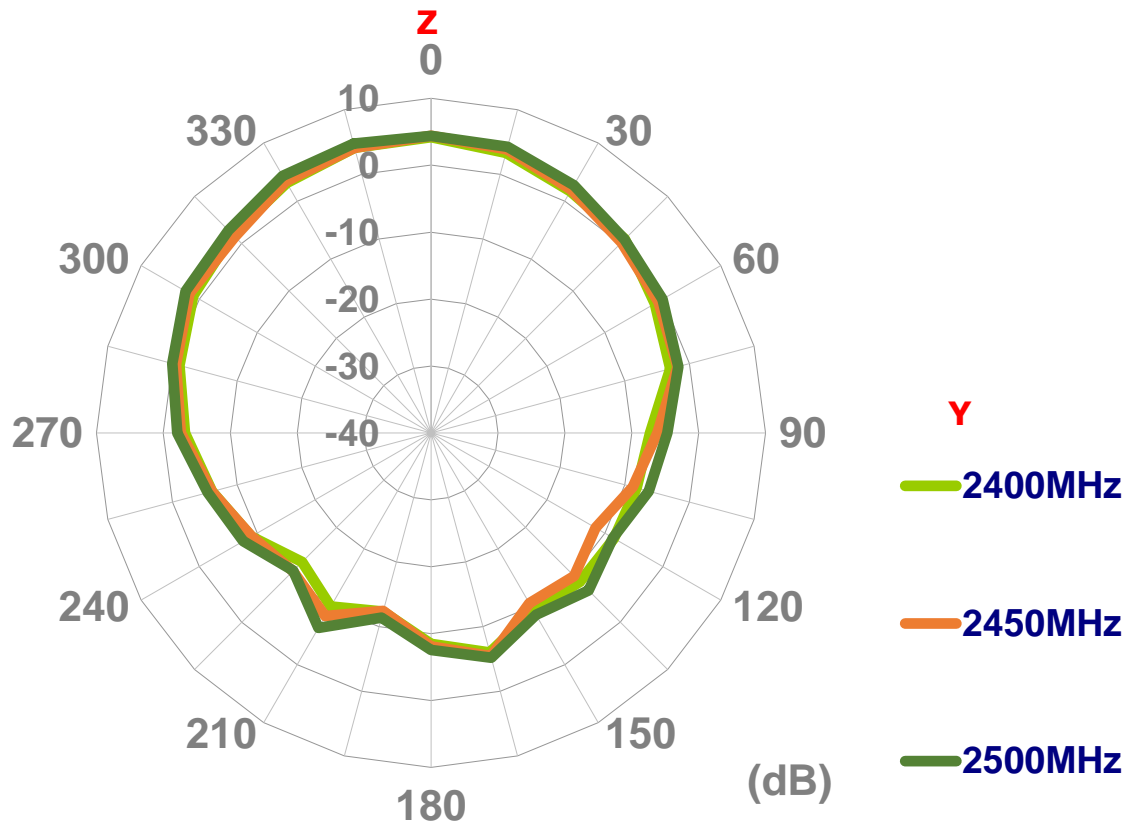

5. 3D Radiation Patterns

5.1 Free Space

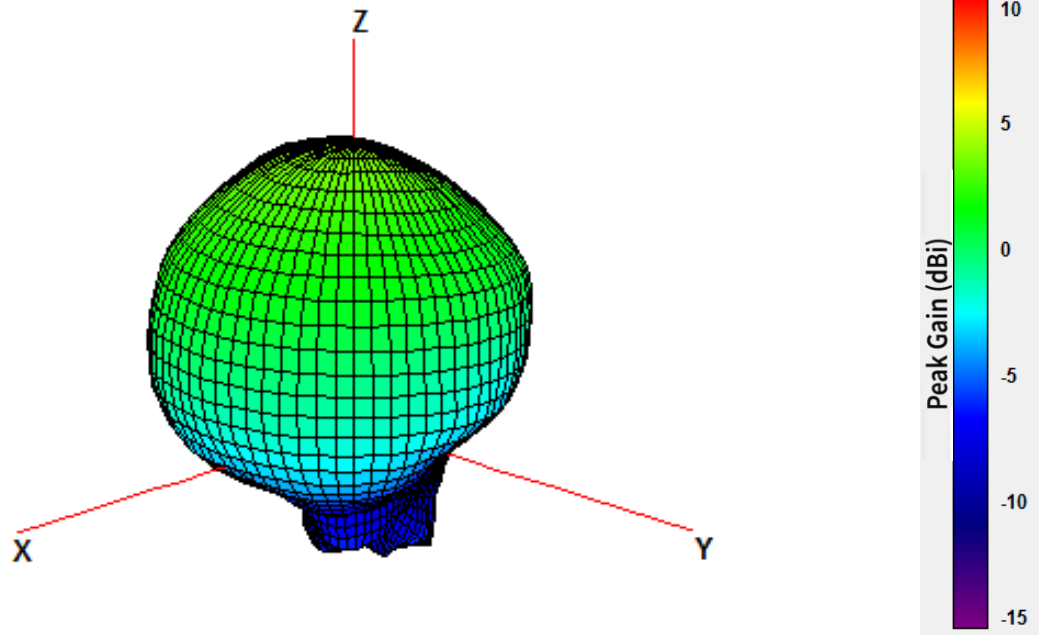

2400MHz

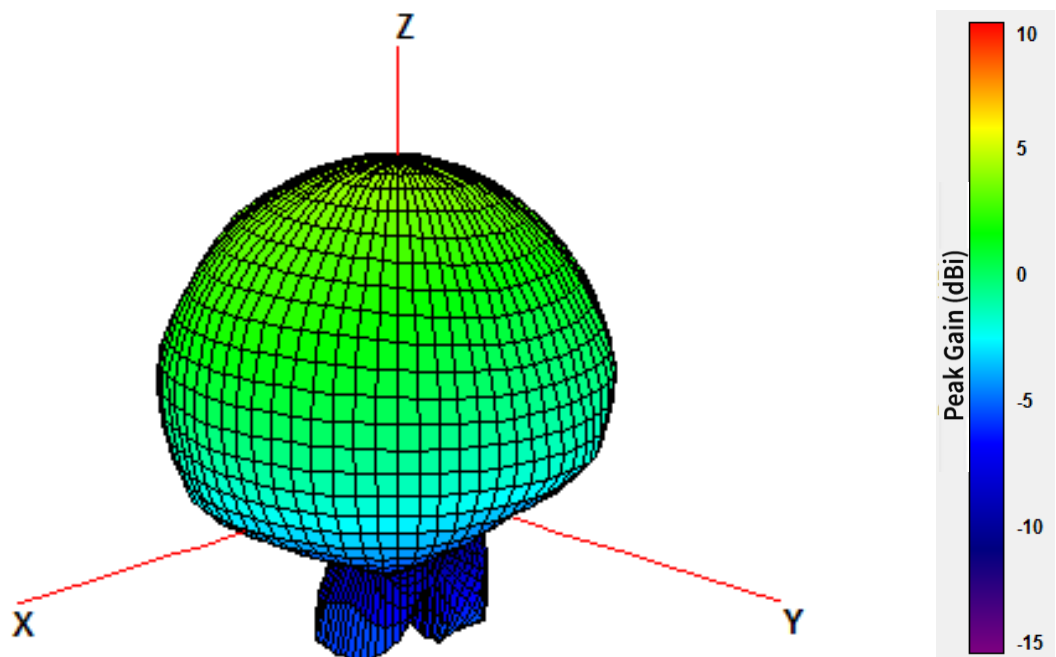

2450MHz

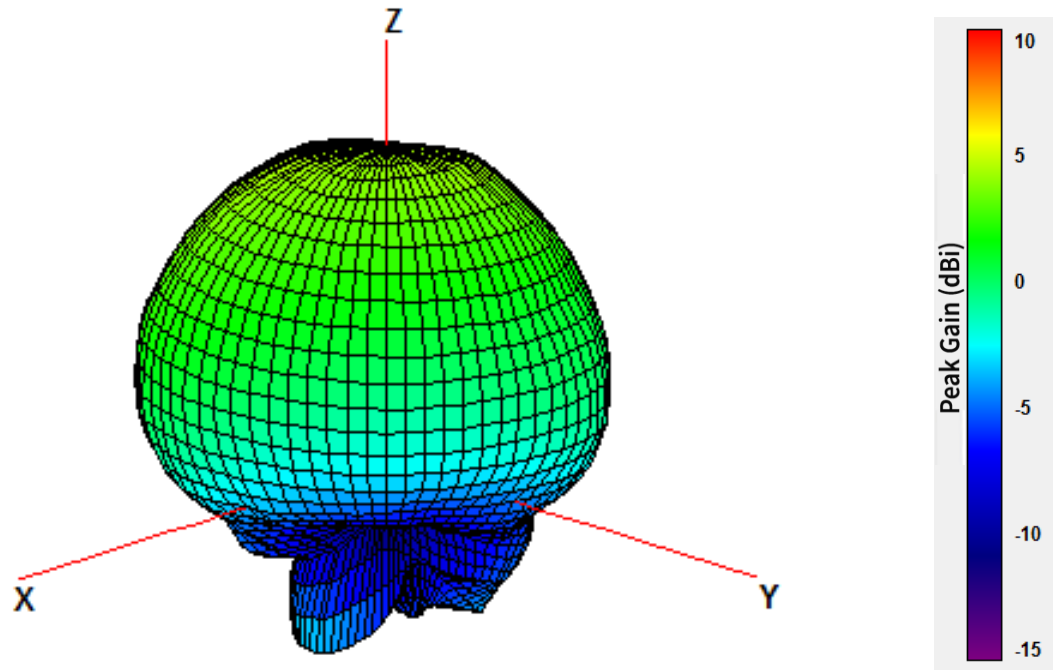

2500MHz

6. Mechanical Drawing (Units: mm)

6.1 Antenna Dimension and Drawing

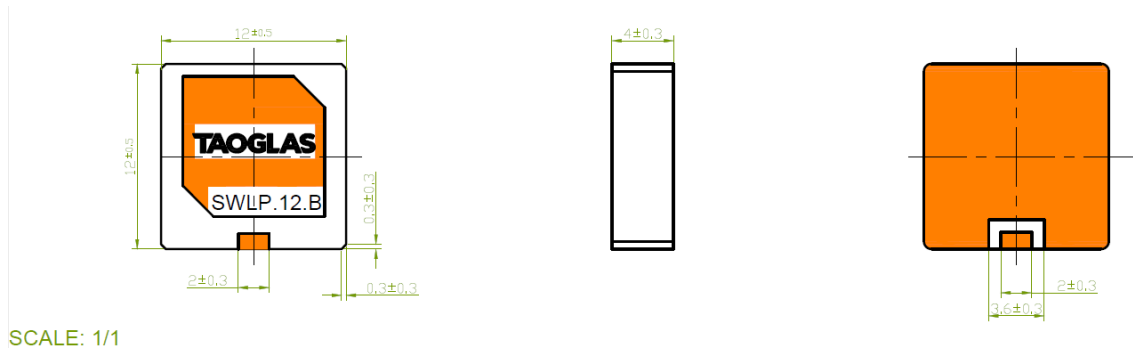

6.2 Antenna Footprint

Top Copper	Top Solder Paste
<p>Pads 1, 2, 3, 4, 5, 6, 7 and 9 are the same size, it should be connected to GND. Pad 8 should be connected to a 50 ohm transmission line.</p>	<p>Pads 1, 2, 3, 4, 5, 6, 7 and 9 are the same size.</p>
Top Solder Mask	Composite Diagram
<p>Pads 1, 2, 3, 4, 5, 6, 7 and 9 are the same size. This drawing is a negative of solder mask. Black regions are anti-mask.</p>	

- NOTE:
- 1. Ag Plated area
 - 2. Solder Mask area
 - 3. Copper area
 - 4. Paste area
 - 5. Keepout Region area
 - 6. Ground keepout should extend through all layers to minimize coupling from RF feed to ground.
 - 7. Any vias in pads should be either filled or tented to prevent solder from wicking away from the pad during reflow.
 - 8. The dimension tolerances should follow standard PCB manufacturing guidelines.

*Taoglas is able to provide CAD drawing file to customers for evaluation.

7. Antenna Integration Guide

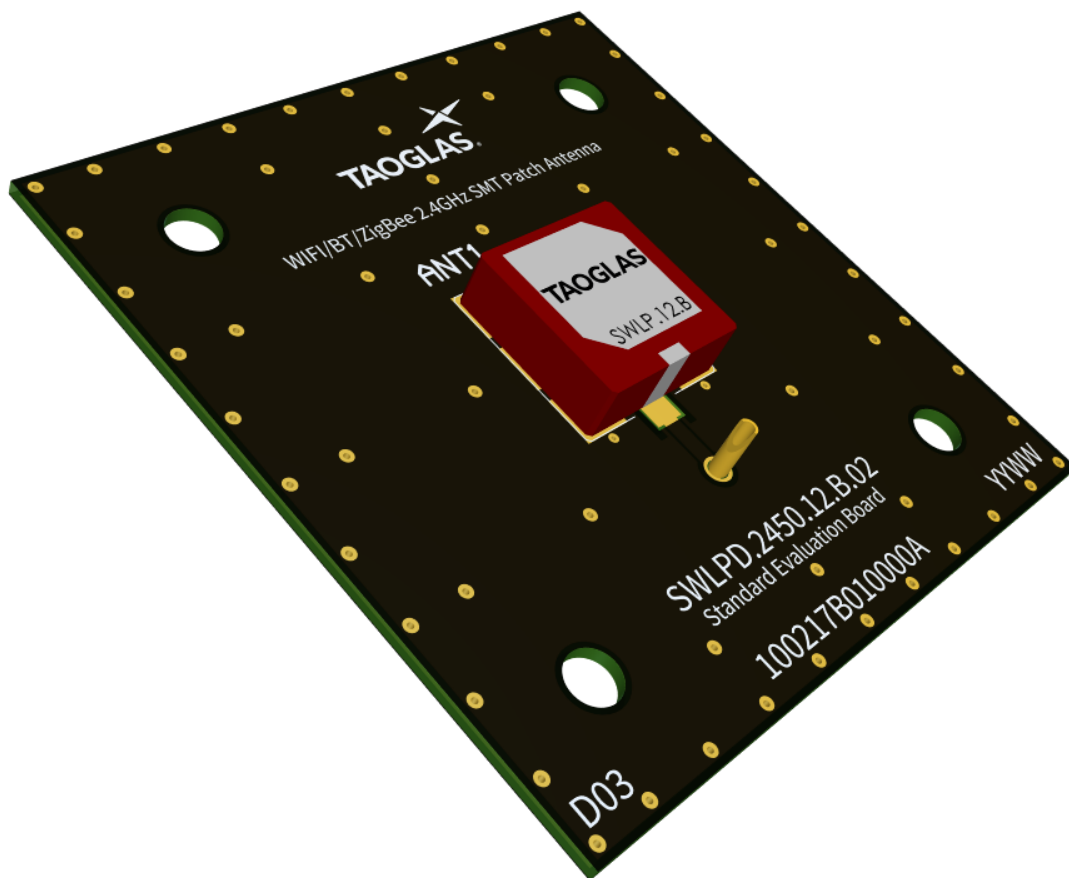
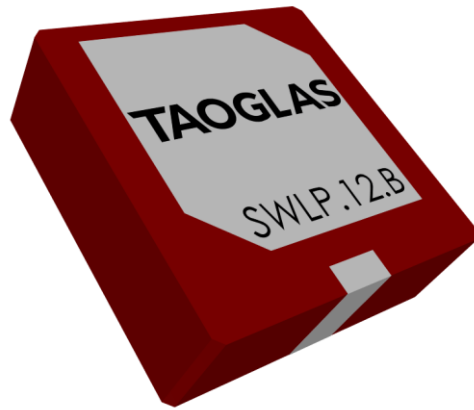

7.1 Schematic Symbol and Pin Definition

The circuit symbol for the antenna is shown below. The antenna has 9 pins as indicated below.

Pin	Description
1	RF Feed
2, 3, 4, 5, 6, 7, 8, 9	Ground

SWLP.2450.12.4.B.02
ANT1

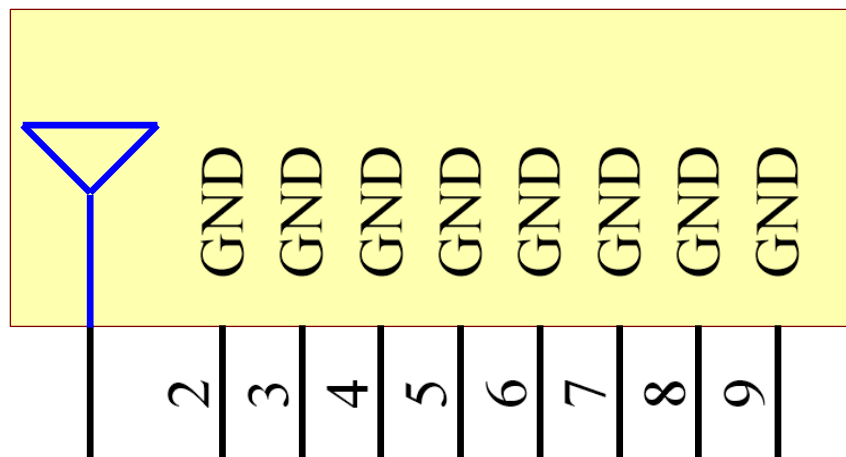

7.2 Antenna Integration

The antenna should be placed at the center of the ground plane with a length and width of 50mm. Maintaining a square symmetric ground plane shape and symmetric environment around the antenna is critical to maintaining the excellent axial ratio and phase center performance shown in this datasheet.



Top Side w/ Solder Mask

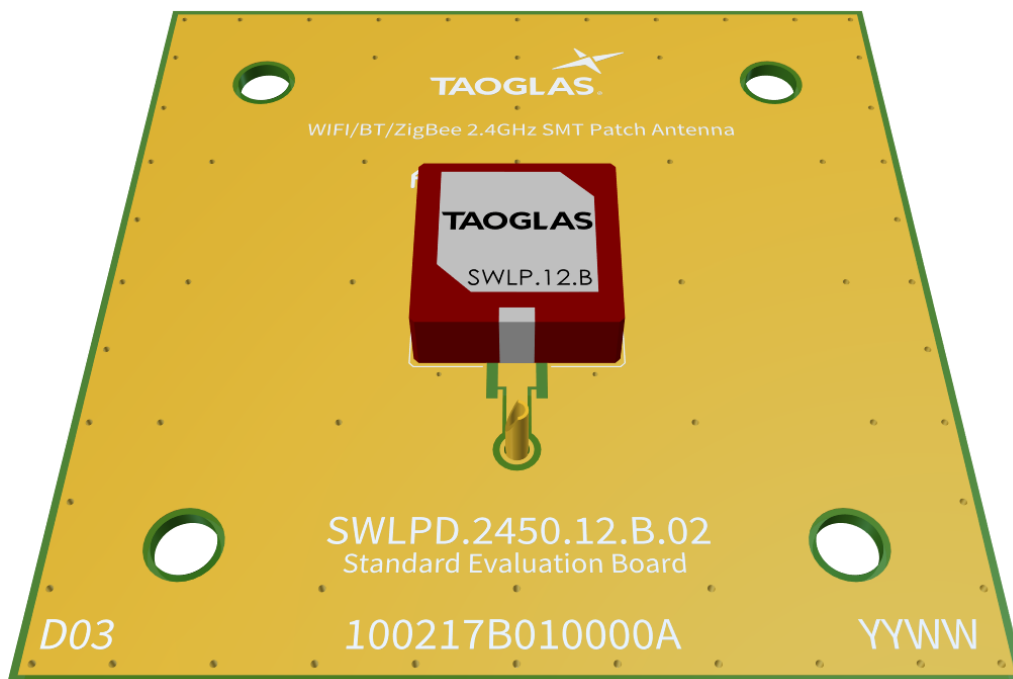

Top Side w/o Solder Mask

7.3 PCB Layout

The footprint and clearance on the PCB must comply with the antenna specification. The PCB layout shown in the diagram below demonstrates the antenna footprint.

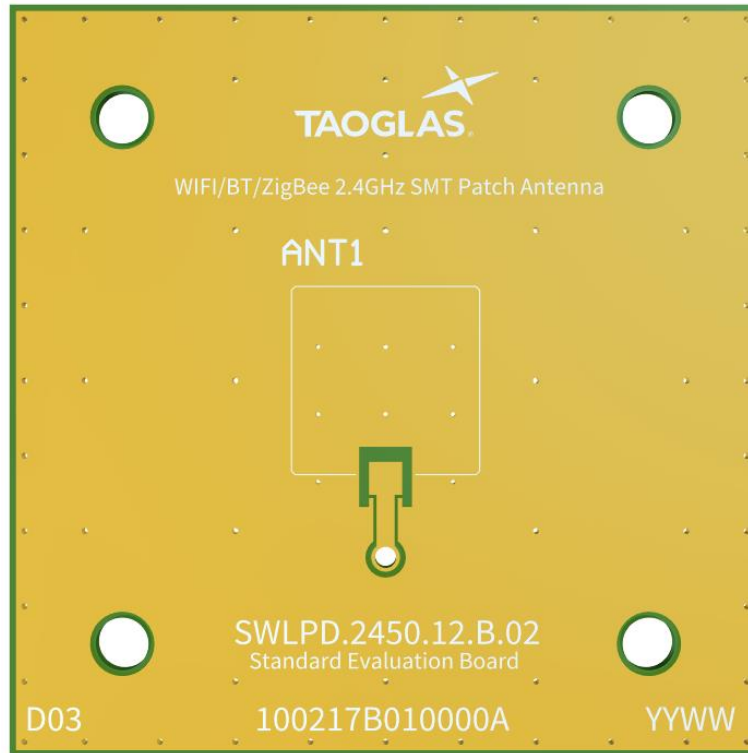

Topside

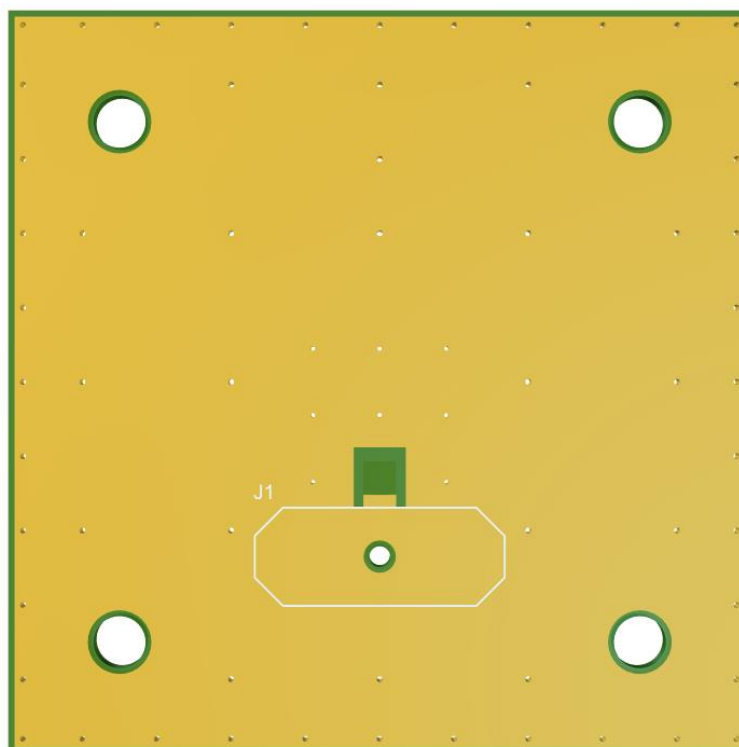

Bottom Side

7.4 Evaluation Board



Topside

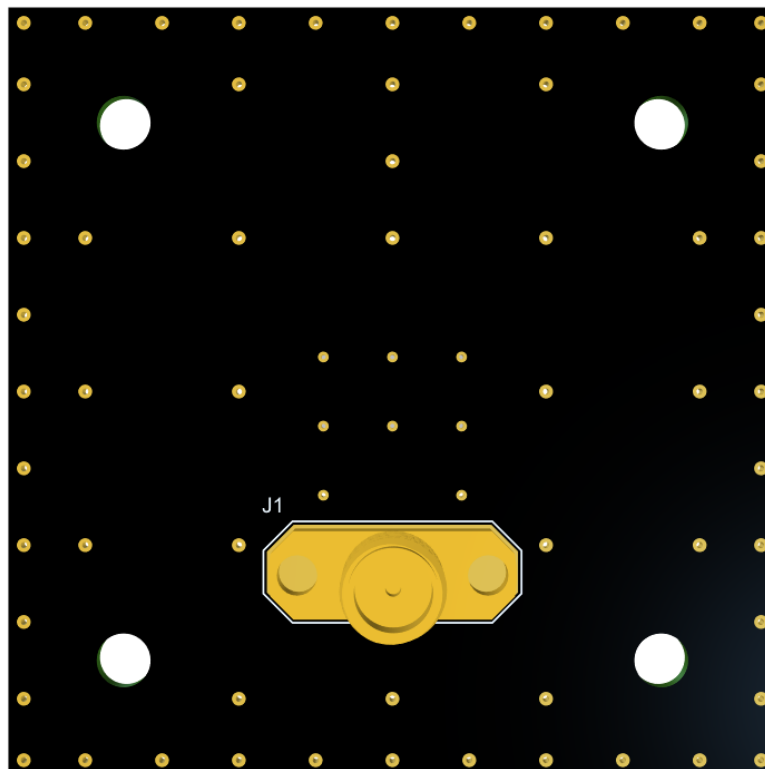

Bottom Side

8. Mechanical Drawing - Evaluation Board

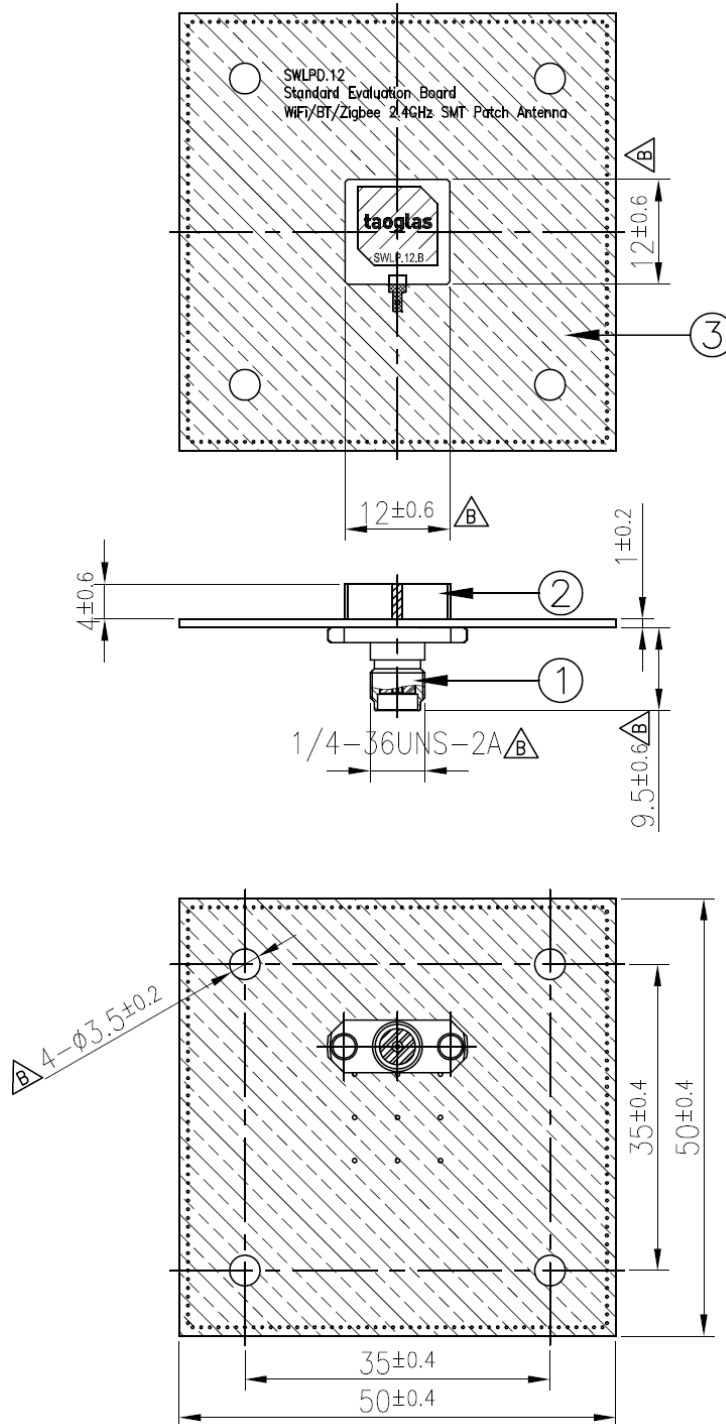

Notes

- 1. Silver area
- 2. Copper area
- 3. Solder mask

	Name	P/N	Material	Finish	QTY
1	PCB SMA(F) ST	200417B000000A	Brass	Au Plated	1
2	SWLP.12 Patch (12x12x4mm)	001517B030000A	Ceramic	Clear	1
3	SWLPD.12 PCB (50x50x1mm)	100217B010000A	Composite 1.0t	N/A	1

9. Packaging

500pcs SWLP.2450.12.4.B.02 per Tape & Reel
 Dimensions - Ø330*37.4mm

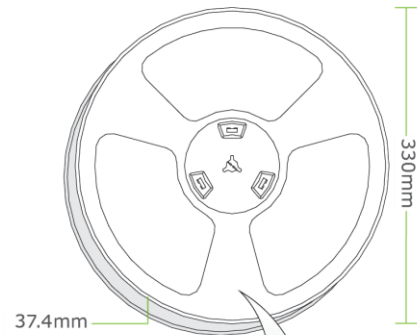

1 Tape and Reel per Small Carton
 Carton Dimensions - 340*350*67mm

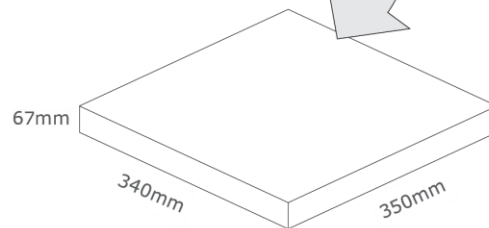

2000pcs per Large Carton
 Carton Dimensions - 370*370*300mm

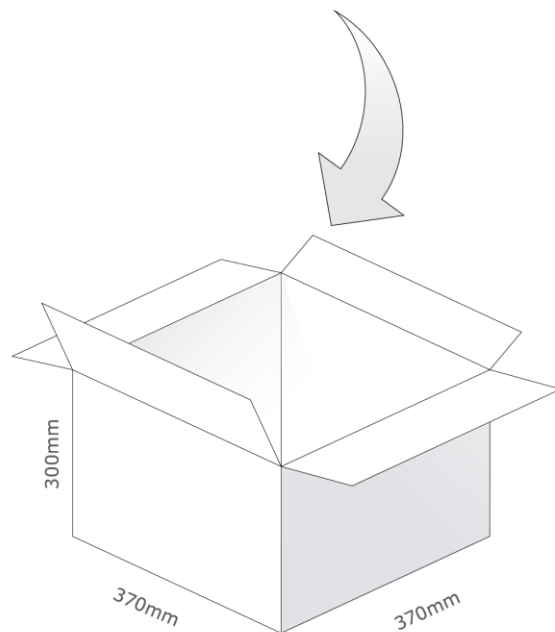

Changelog for the datasheet

SPE-13-8-007 – SWLP.2450.12.4.B.02

Revision: L (Current Version)	
Date:	2023-03-16
Changes:	Antenna Integration Guide Added
Changes Made by:	Cesar Sousa

Previous Revisions

Revision: K	
Date:	2022-02-28
Changes:	Updated Specifications
Changes Made by:	Paul Doyle

Revision: J	
Date:	2019-11-25
Changes:	Updated Packaging
Changes Made by:	Paul Doyle

Revision: I (Current Version)	
Date:	2019-02-26
Changes:	Updated graphs based on new data
Changes Made by:	Jack Conroy