

- ⊗ Compliant with ANSI X3T111, Fiber Channel
- ⊗ FC-PH-3 for quarter/full speed applications, SMPTE, IEEE1394 Firewire
- ⊗ Pick and place compatible
- ⊗ IC grade package withstands 225°C peak Temperature profile
- ⊗ Moisture Sensitivity Level: 3

Electrical Specifications @ 25 °C – Operating Temperature – 55 °C to +125 °C

Part Number	Turns Ratio (±5%)	Primary Inductance (µH MIN)	Rise Time @20 & 80% (pS MAX)	DCR (Ω MAX)	Hi-Pot (Vrms MIN)	Insertion Loss (dB MAX)	Application Nominal Bit Rate (Mbaud)
T-330ACT	1CT : 1CT	26	350.000	0.2	1500	-1.50	265.6 (fullspeed)
T-531ACT	1CT : 1CT	7.5	325.000	0.2	1500	-2.00	531 (full speed)
T-1062ACT	1CT : 1CT	3.75	280.000	0.2	1500	-2.00	1062.5 (fullspeed)
T-1250ACT	1CT : 1CT	3.75	280.000	0.2	1500	-2.00	1,250 (fullspeed)
T-1485ACT	1CT : 1CT	3.75	280.000	0.2	1500	-2.00	1,485 (fullspeed)

Mechanical

Electrical Schematic

T-330ACT / T-531ACT / T-1062ACT / T-1250ACT / T-1485ACT

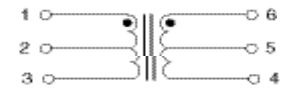
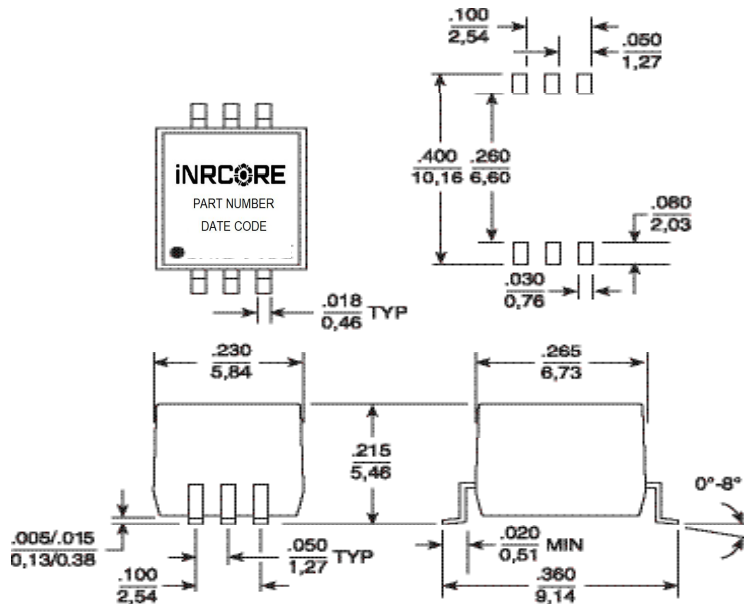

ApplicationNotes

iNRCORE, LLC has designed Fibre Channel dual transformers specifically for point to point coupling to 150 twinax cable. The isolation transformers protect the station from static charges that may develop on the cable, and prevents ground loop currents from being transferred between stations. The devices have also been designed to provide com-mon mode rejection within the transmission band and thus reduce EMI. The wide bandwidth of these devices minimizes data dependent jitter by providing fast signal rise times. Low-end bandwidth also minimizes base-line wander, another contributor to jitter. The dual package allows connection of both transmit and receive channels, as shown in the application cir-cuit below. Surface-mount packaging also allows a cost-effective solution.

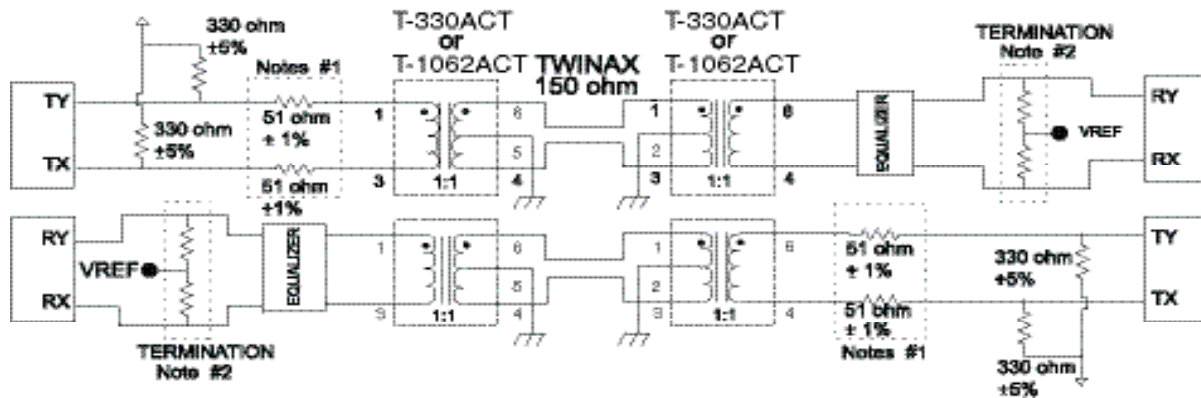

Fig. 1 - Typical Application Circuit

1. The transformer, 51Ω resistors, and the impedance of the driver are matched to achieve the best return loss (S11) for the transmitter of the 150Ω system.
2. The total impedance of termination resistor network is 150 Ω.
3. When laying out PCB, transmission line methods must be utilized to maintain return loss and signal integrity. Transformer must be located within .50" of the DB9 connector.
4. It is recommended that the center tap (CT) of transformer(s), cable side, be connected to earth/chassis (cable shield) ground either directly or via a transient voltage suppressor (TVS) type component and earth/chassis ground should be "AC-coupled" to signal (digital) ground through a .027uF, 500V capacitor.