

QorIQ T2080 Reference Design Board (T2080RDB-PC) User Guide



Contents

Chapter 1 Overview.....	4
1.1 Related documentation.....	4
1.2 Acronyms and abbreviations.....	4
1.3 T2080 silicon features.....	5
1.4 T2080RDB-PC board features.....	6
1.5 Block diagram.....	8
Chapter 2 Architecture	10
2.1 Processor.....	10
2.2 Power.....	10
2.3 Reset.....	11
2.4 Clocks.....	12
2.5 DDR.....	13
2.6 SerDes port.....	14
2.6.1 PCI Express support.....	15
2.6.2 XFI 10G optics port support.....	15
2.6.3 XFI 10GBase-T port support.....	16
2.6.4 SATA support.....	16
2.7 Ethernet controllers	16
2.8 Ethernet Management Interface.....	17
2.9 I2C.....	18
2.10 SPI interface	19
2.11 Local bus.....	19
2.12 SDHC interface.....	19
2.13 USB interface.....	20
2.14 RS-232.....	21
2.15 JTAG/COP port.....	22
2.16 Connectors, Headers, Jumper, Push buttons, and LEDs.....	24
2.16.1 Connectors.....	24
2.16.2 Headers.....	25
2.16.3 Jumper.....	25
2.16.4 Push buttons.....	25
2.16.5 LEDs.....	25
2.17 Temperature.....	26
2.18 DIP switch definition.....	27
Chapter 3 CPLD Specification.....	30
3.1 Register descriptions.....	30
3.1.1 CPLD Memory map.....	30
3.1.2 Chip ID1 register (CHIPID1).....	30
3.1.3 Chip ID2 register (CHIPID2).....	31
3.1.4 Hardware version register (HWVER).....	31
3.1.5 Software version register (SWVER).....	32
3.1.6 Reset control register (RSTCON).....	33
3.1.7 Flash control and status register (FLHCSR).....	34
3.1.8 Thermal control and status register (THMCSR).....	35
3.1.9 Panel LED control and status register (LEDCSR).....	36
3.1.10 SFP+ control and status register (SFPCSR).....	37
3.1.11 Miscellanies control and status register (MISCCSR).....	38

3.1.12 Boot configuration override register (BOOTOR)..... 39
3.1.13 Boot configuration register 1 (BOOTCFG1)..... 39
3.1.14 Boot configuration register 2 (BOOTCFG2)..... 40

Appendix A Revision history..... 42

Chapter 1

Overview

The T2080RDB-PC is a high-performance computing evaluation, development, and test platform supporting the T2080 QorIQ® Power Architecture® processor. The T2080RDB-PC is optimized to support the high-bandwidth DDR3L memory and a full complement of high-speed SerDes ports. This system has two working modes, the Standalone mode and the PCIe Endpoint mode. The motherboard, inside the T2080RDB-PC, is a PCIe form factor card and it is installed in a custom 1U chassis. The system is in standalone mode by default and you can remove the PCIe from its chassis for PCIe Endpoint mode operation.

NOTE

The T2080RDB boards are using NXP C29x Crypto Coprocessor series silicon.

1.1 Related documentation

The table below lists the related documentation:

Table 1. Related documentation

Document name	Description
QorIQ T2080 Reference Manual	This document provides a detail description on the T2080 QorIQ multicore processor and on some of its features such as memory map, serial interfaces, power supply, chip features, and clock information.
T2080 Product Brief	This document provides an overview of the NXP T2080 features and examples of the T2080 usage.
QorIQ T2080 Data Sheet	This document contains the T2080 information on pin assignments, electrical characteristics, hardware design, considerations, package information, and ordering information.

NOTE

Some of the documents mentioned above may be available only under a non-disclosure agreement (NDA). To request access to these documents, contact your local field applications engineer or sales representative.

1.2 Acronyms and abbreviations

Table 2. Acronyms and abbreviations

Usage	Description
COP	Common On-chip Processor
CPC	CoreNet Platform Cache
CPLD	Complex Programmable Logic Device
DIMM	Dual In-Line Memory Module
DIP	Dual In-Line Package
DMA	Direct Memory Access
DPAA	Data Path Acceleration Architecture
DRAM	Dynamic Random Access Memory
DUT	Device Under Test

Table continues on the next page...

Table 2. Acronyms and abbreviations (continued)

Usage	Description
EC	Ethernet Controllers
ECC	Error Detection and Correction
EMI	Ethernet Management Interfaces
eSDHC	enhanced Secure Digital Host Controller
eSPI	enhanced Serial Peripheral Interface
FPGA	Field-Programmable Gate Array
HW	Hardware
I2C	Inter - Integrated Circuit
IFC	Integrated Flash Controller
JTAG	Joint Test Action Group
PCIe/PEX	PCIe = PCI Express = PEX
PLD	Programmable Logic Device
POR	Power-on Reset
QMan	Queue Manager
SATA	Serial Advanced Technology Attachment
SD	Secure Digital
SerDes	Serializer/Deserializer
SGMII	Serial Gigabit Media Independent Interface
SPI	Serial Peripheral Interface
SW	Switch
SYSCLK	System Clock
UART	Universal Asynchronous Receiver/Transmitter
VCC	Voltage for Circuit
VTT	Voltage for Terminal

1.3 T2080 silicon features

The T2080 silicon features are as follows:

- Four e6500 cores, built on Power Architecture technology, sharing a 2 MB L2 cache
- 512 kB CoreNet Platform cache (CPC)
- Hierarchical interconnect fabric:
 - CoreNet fabric supporting coherent and non-coherent transactions with prioritization and bandwidth allocation among CoreNet endpoints
 - Queue Manager (QMan) fabric supporting packet-level queue management and quality of service scheduling
- One 32/64-bit DDR3 SDRAM memory controller:
 - DDR3 and DDR3L with ECC and interleaving support

- Memory pre-fetch engine
- Data Path Acceleration Architecture (DPAA) incorporating acceleration for the following functions:
 - Packet parsing, classification, and distribution (Frame Manager 1.1)
 - Queue management for scheduling, packet sequencing, and congestion management (Queue Manager 1.1)
 - Hardware buffer management for buffer allocation and de-allocation (Buffer Manager 1.1)
 - Cryptography Acceleration (SEC 5.2)
 - RegEx Pattern Matching Acceleration (PME 2.1)
 - Decompression/Compression Acceleration (DCE 1.0)
 - DPAA chip-to-chip interconnect, using RapidIO Message Manager (RMan 1.0)
- 16 SerDes lanes at up to 10 GHz.
- Eight Ethernet interfaces, supporting combinations of:
 - Up to four 10 Gbit/s Ethernet MACs
 - Up to eight 1 Gbit/s Ethernet MACs
 - Up to four 2.5 Gbit/s Ethernet MACs
 - IEEE 1588 standard support.
- High-speed peripheral interfaces:
 - Four PCI Express controllers (two supporting PCIe 2.0 and two supporting PCIe 3.0)
 - Two Serial RapidIO 2.0 controllers running at up to 5 GHz with Type 11 messaging and Type 9 data streaming support
- Additional peripheral interfaces:
 - Two Serial ATA (SATA 2.0) controllers
 - Two high-speed USB 2.0 controllers with integrated PHY
 - Enhanced secure digital host controller (SD/MMC/eMMC)
 - Enhanced Serial peripheral interface (eSPI)
 - Four I2C controllers
 - Four 2-pin UARTs or two 4-pin UARTs
 - Integrated flash controller supporting NAND and NOR flash
- Three 8-channel DMA engines
- 896 FC-PBGA package, 25 mm x 25 mm, 0.8 mm pitch

1.4 T2080RDB-PC board features

The T2080RDB-PC board features are as follows:

- SerDes connections
 - 16 lanes configuration:
 - SerDes-1 Lane A-B: to two 10GSFP+ (MAC9 and MAC10)
 - SerDes-1 Lane C-D: to two 10GBase-T (MAC1 and MAC2)
 - SerDes-1 Lane E-H: to PCIe slot (PCIe4 x4, Gen3)
 - SerDes-2 Lane A-D: to PCIe Goldfinger (PCIe1 x4, Gen2)
 - SerDes-2 Lane E-F: to C293 secure coprocessor (PCIe2 x2)

- SerDes-2 Lane G-H: to SATA1 and SATA2
- DDR controller
 - Supports data rates of up to 1600 MHz or 1866 MHz
 - Supports one DDR3L DIMM of single, dual-rank types
 - DDR power supplies 1.35 V to all devices with automatic tracking of VTT
- IFC/Local Bus
 - NAND flash: 8 bit, async, up to 1 GB
 - NOR: 16 bit, non-multiplexed, up to 128 MB, NOR devices support 8 virtual banks
- Ethernet
 - Two onboard RGMII 10/100/1G Ethernet ports
 - Two onboard XFI 10GEDC for 10G SFP+ port
 - Two onboard XFI 10GBase-T ports
- CPLD
 - PCBA version identify
 - Manages system power and reset sequencing
 - Configures DUT, board, clock with dynamic
 - Reset and interrupt monitor and control
 - General fault monitoring and logging
- Clocks
 - System and DDR clock (SYSCLK, DDRCLK)
 - Switch selectable to one of the 16 common settings in the interval 64 MHz-166 MHz
 - Software programmable in 1 MHz increments from 1-200 MHz
 - SerDes clocks
 - Provides clocks to all SerDes blocks and slots
 - 100 MHz
 - 156.25 MHz
- Power supplies
 - Dedicated PMBus regulator for core power; adjustable from 0.7 V to 1.3 V at 60 A
- USB
 - Supports two USB 2.0 ports with integrated PHYs: Two type A ports with 5 V @ 1.5 A per port
- MicroSD card
 - MicroSD port connects directly to MicroSD or TF
- SPI
 - Onboard support of SPI flash
- Other I/O
 - Two serial ports
 - Two I2C ports

1.5 Block diagram

The T2080RDB-PC supports two modes of operation, the Standalone mode and the Endpoint mode. There is one configuration in the Standalone mode and second configurations is in the Endpoint mode, the major differences are in the PCIe support. All configurations have NXP C293, 4x XFI, 2x RGMII, DDR, NOR, NAND, SPI EEPROM, I2C EEPROM, and GPIO. FPGA/CPLD controls the muxing.

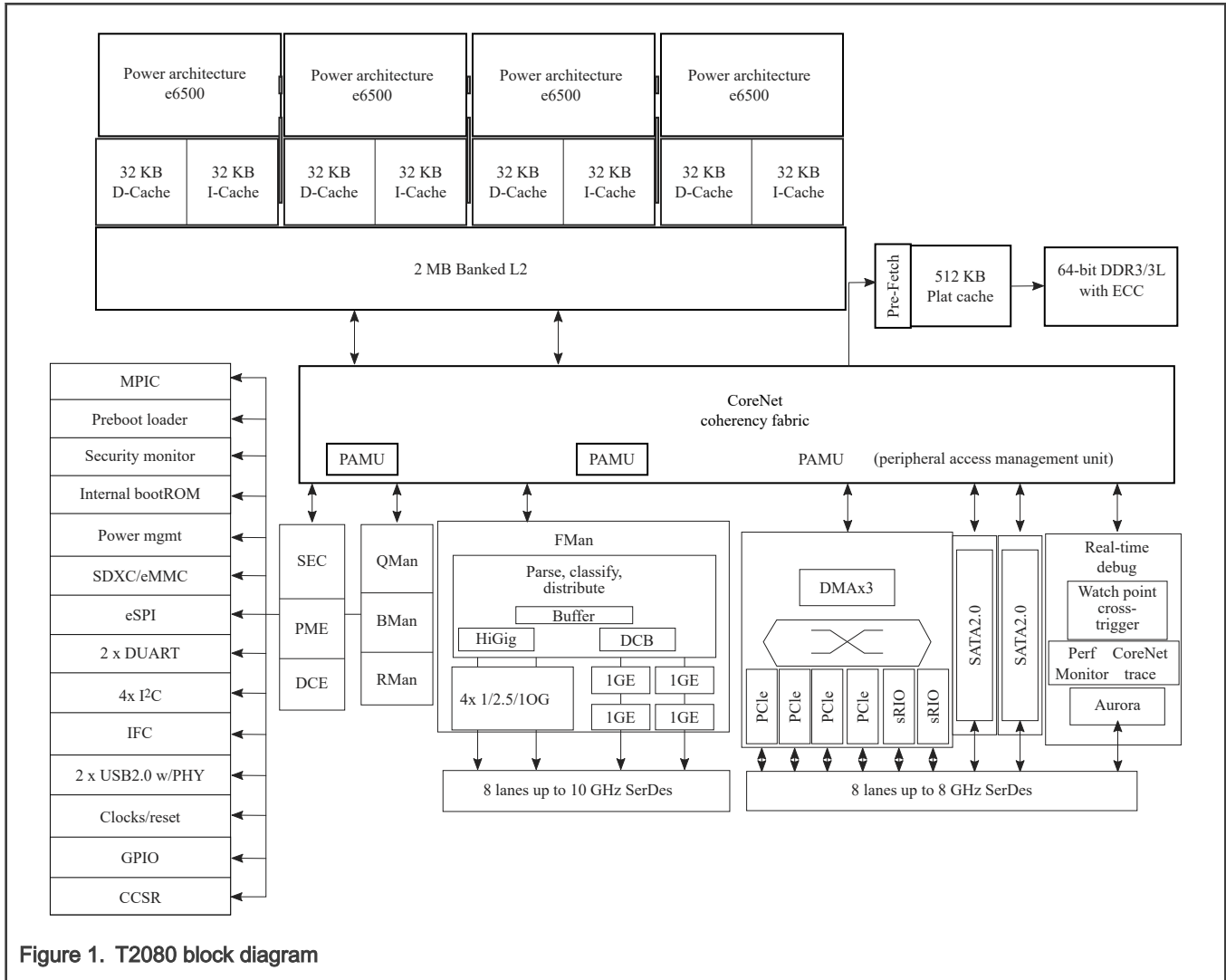

Figure 1. T2080 block diagram

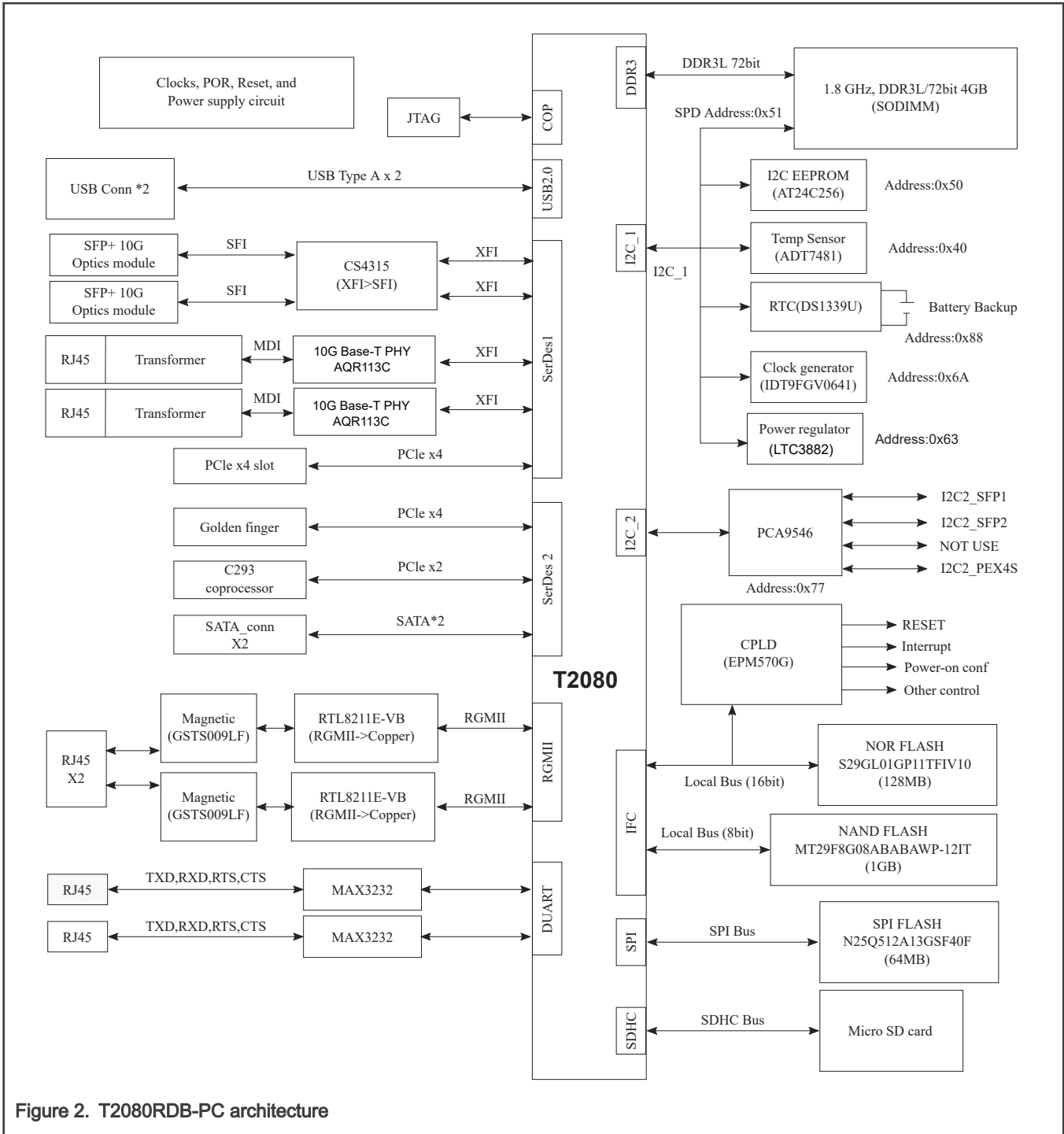

Figure 2. T2080RDB-PC architecture

Chapter 2

Architecture

This section explains the architecture of T2080RDB-PC:

- [Processor](#)
- [Power](#)
- [Reset](#)
- [Clocks](#)
- [DDR](#)
- [SerDes port](#)
- [Ethernet controllers](#)
- [Ethernet Management Interface](#)
- [I2C](#)
- [SPI interface](#)
- [Local bus](#)
- [SDHC interface](#)
- [USB interface](#)
- [RS-232](#)
- [JTAG/COP port](#)
- [Connectors, Headers, Jumper, Push buttons, and LEDs](#)
- [Temperature](#)
- [DIP switch definition](#)

2.1 Processor

The T2080RDB-PC supports many features of the T2080 processor, as detailed in the following sections.

2.2 Power

The power supply system of the T2080RDB-PC system uses power from a standard 6-pin EPS, to provide power to the numerous processors, CPLD, and peripheral devices.

- Monolithic power supply for VCC (powering internal cores and platform logic)
- DUT-specific power rails are instrumented such that current measurement is possible
- Automatic collection of voltage, current, and power is performed for critical supplies
- Mounting holes are provided of sufficient size to allow onboard supplies to be replaced by bench supplies
- All power supplies can be sequenced as per hardware specifications

The power supplies provided are organized into general categories and are described in the individual sections.

The diagram below shows the power supply architecture.

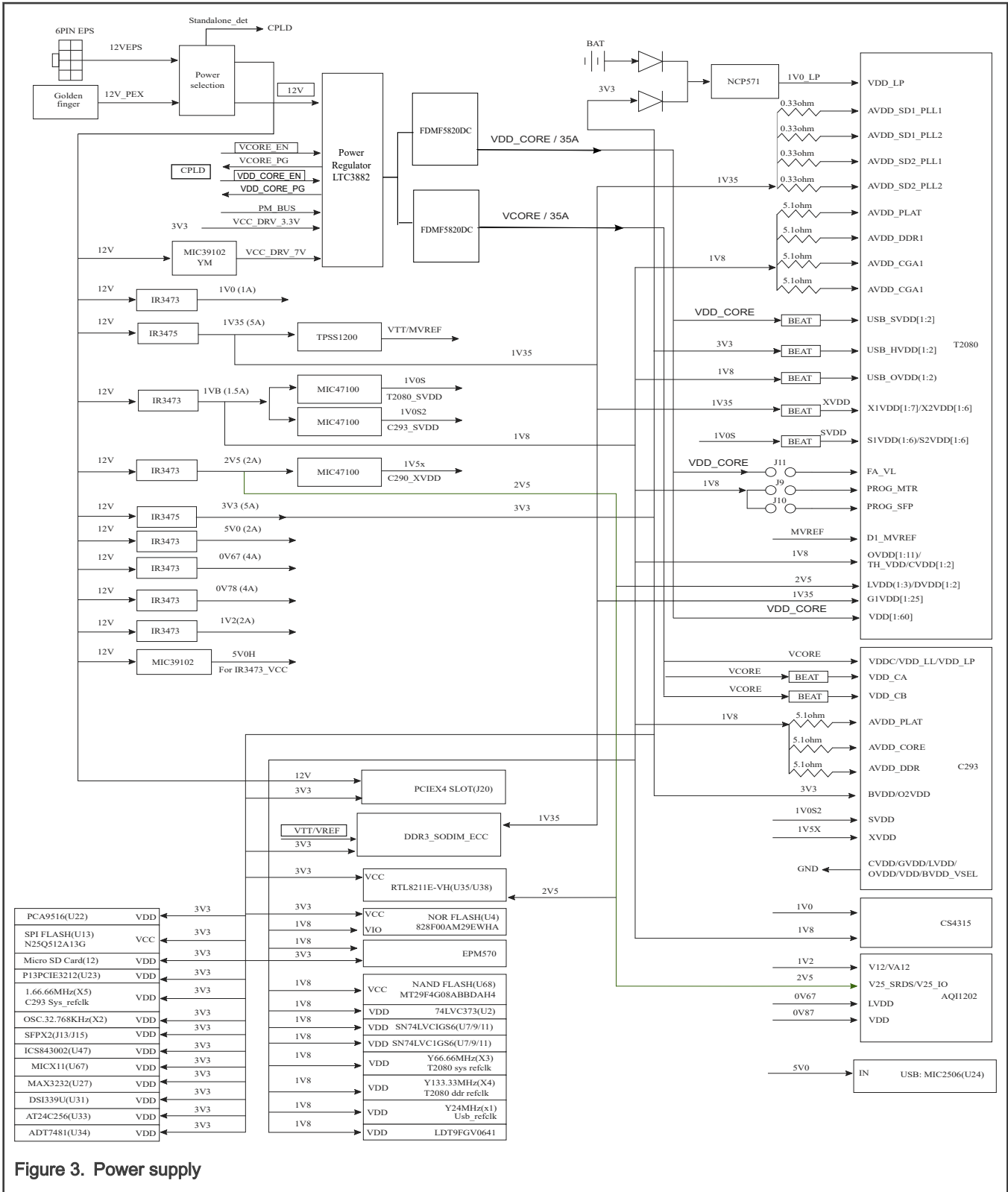

Figure 3. Power supply

2.3 Reset

CPLD manages the reset signals to and from the T2080 processor and other devices on the T2080RDB-PC. The diagram below shows an overview of the reset architecture.

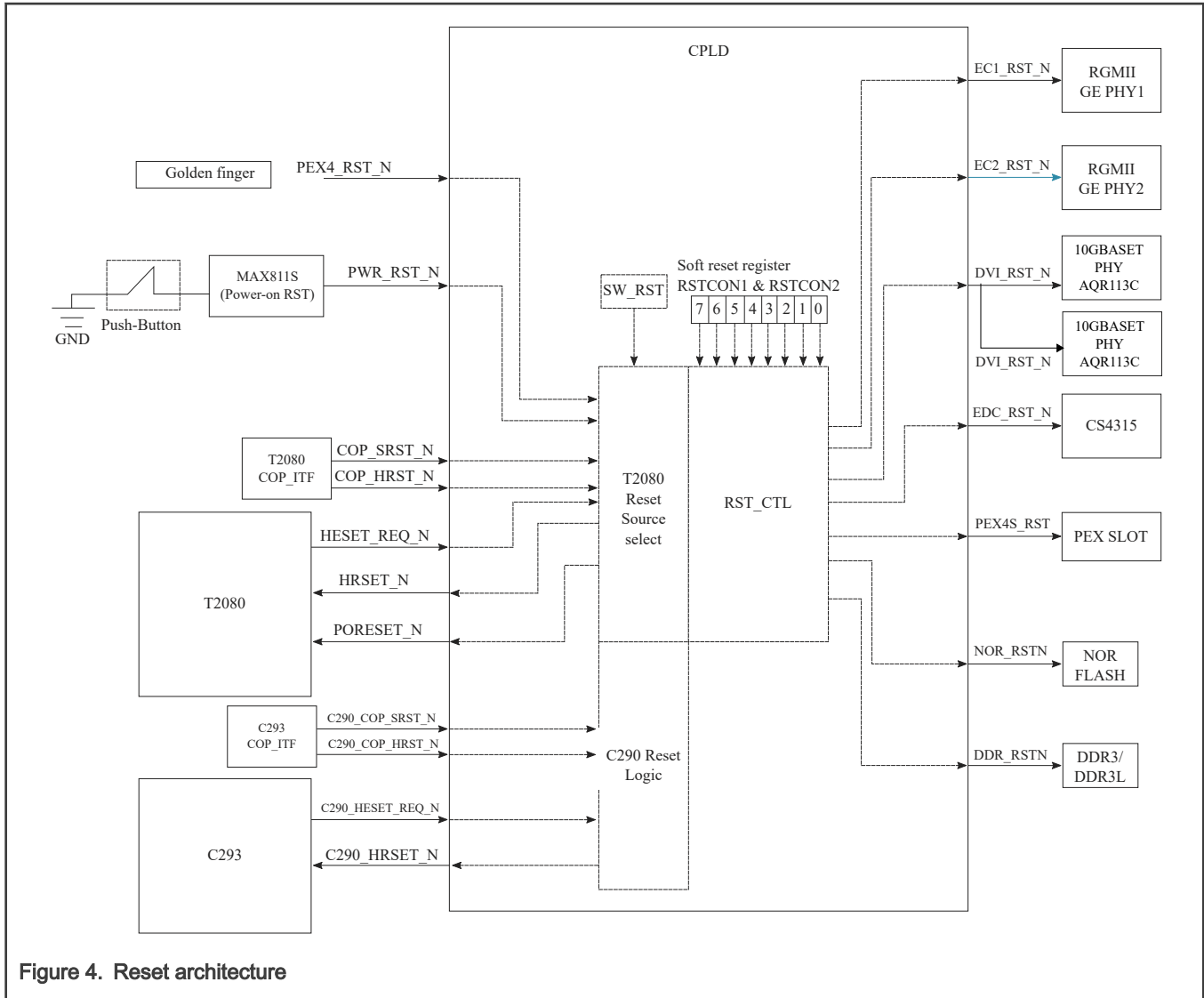

Figure 4. Reset architecture

2.4 Clocks

The clock circuitry provides clocks for the processor, for:

- SYSCLK
- DDRCLK (single-ended and differential)
- SerDes clocks
- Ethernet clocks
- USB clock

The architecture of the clock section is shown in the diagram below.

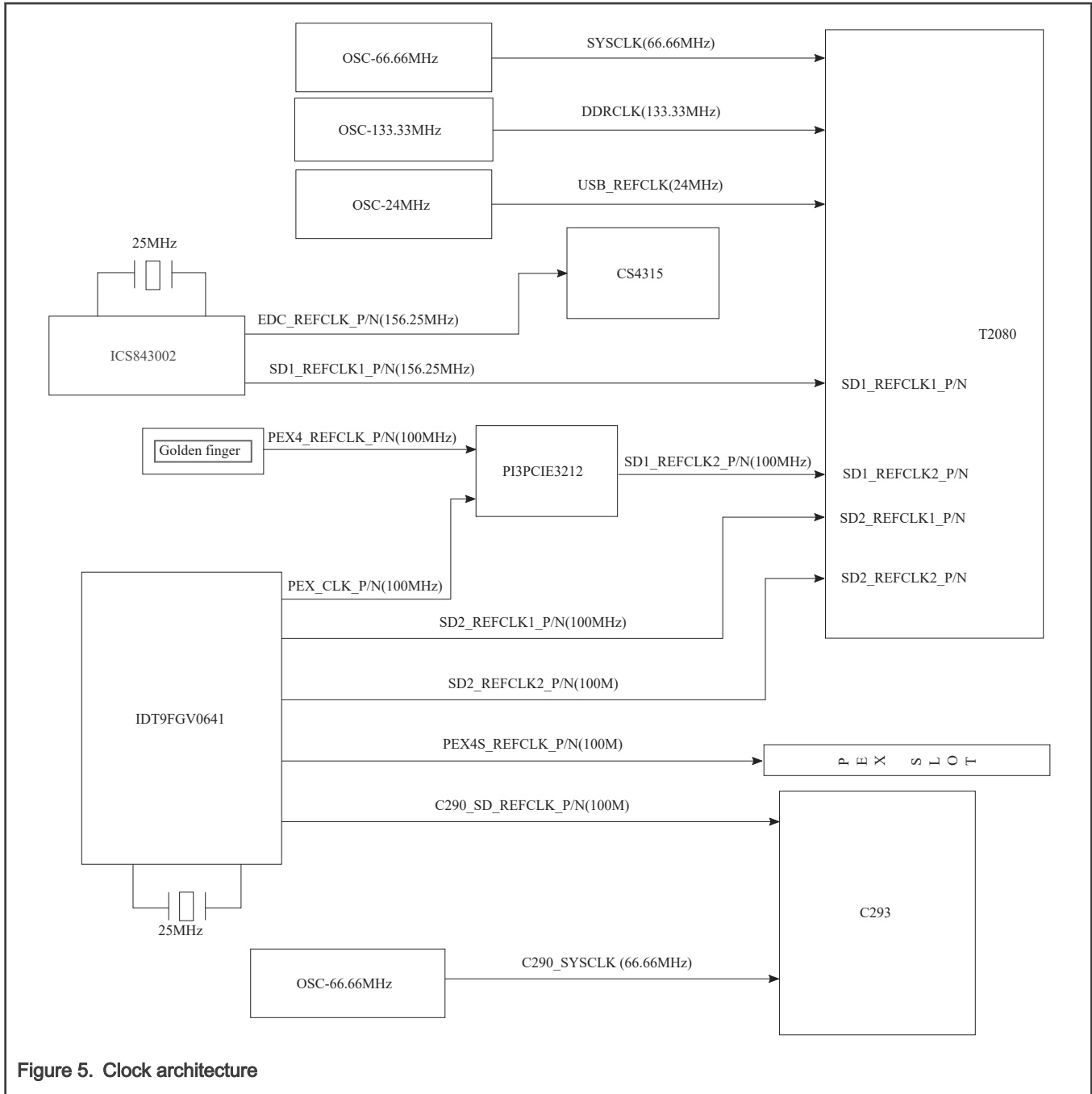

Figure 5. Clock architecture

2.5 DDR

The T2080RDB-PC supports high-speed DRAM, with an SODIM socket, featuring single, dual, and quad-rank support. The memory interface includes the necessary termination and I/O power and is routed to achieve maximum performance of the memory bus, as shown in the diagram below.

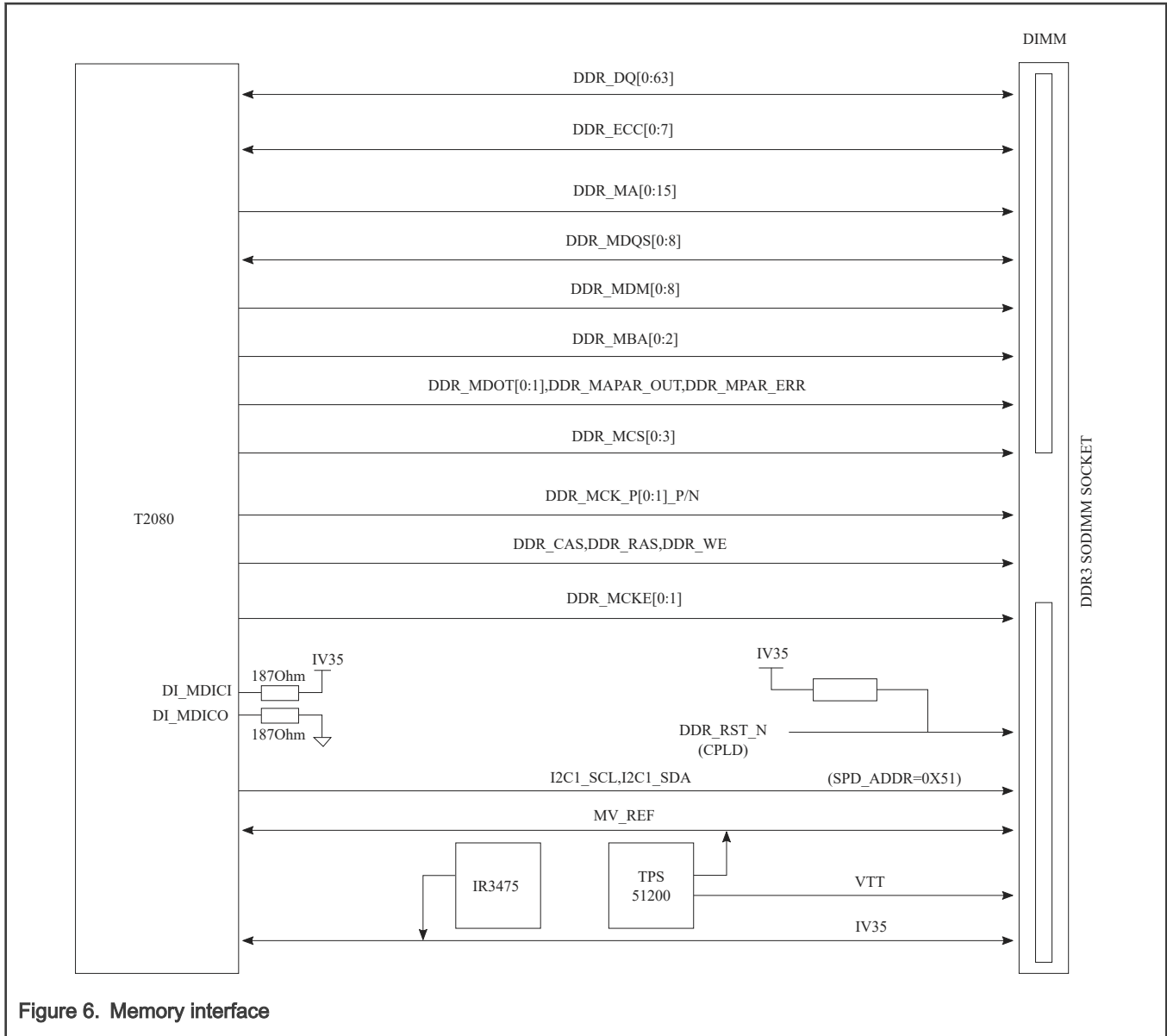

Figure 6. Memory interface

2.6 SerDes port

The T2080 SerDes block provides 16 high-speed serial communication lanes, supporting various protocols, including:

- SGMII 1.25 / 3.125 Gbit/s
- PCI Express (PEX) Gen 1 1X / 2X / 4X 2.5 Gbit/s
- PCI Express (PEX) Gen 2 1X / 2X / 4X 5 Gbit/s
- SATA 1X 1.5 / 3 Gbit/s

The T2080 additionally supports these protocols:

- PCI Express (PEX) Gen 3 1X 8 Gbit/s
- XFI 1X 10.3125 Gbit/s

An overview of the SerDes protocols, which are supported on the T2080RDB, is shown in the table below.

Table 3. SerDes protocols

SERDES1										
SRDS_PRTCL_S1	A	B	C	D	E	F	G	H	Per lane PLL mapping	
66	XFI9	XFI10	XFI1	XFI2	PCIe4				1111	2222
SERDES2										
SRDS_PRTCL_S2	A	B	C	D	E	F	G	H	Per lane PLL mapping	
15	PCIe1				PCIe2	PCIe2	SATA A1	SATA A2	1111	1122

The image below shows the SerDes distribution of T2080RDB-PC.

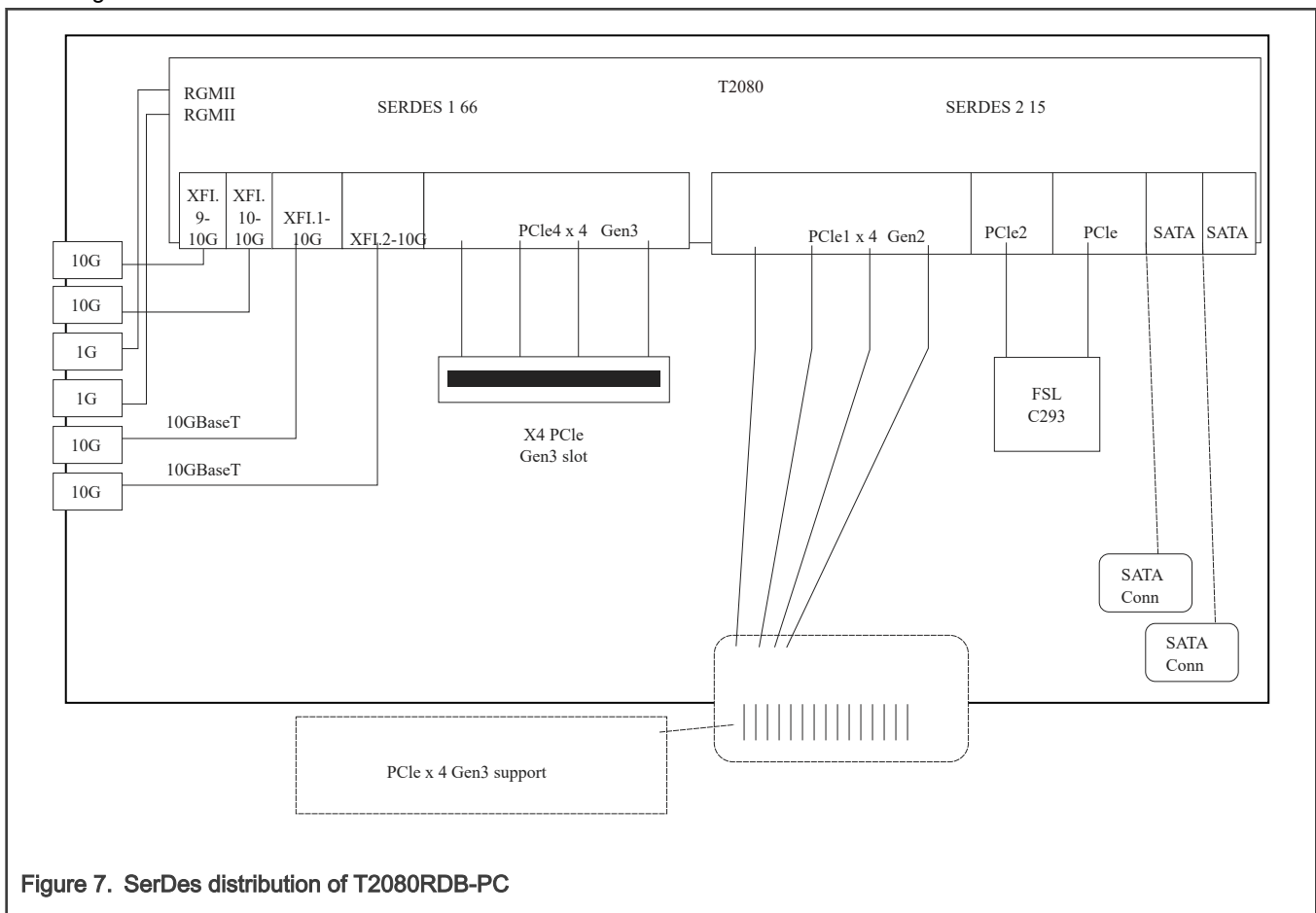

Figure 7. SerDes distribution of T2080RDB-PC

2.6.1 PCI Express support

The T2080RDB-PC supports PCIe x4 Gen 3 for golden finger and PCIe x4 Gen 2 for slot.

2.6.2 XFI 10G optics port support

The T2080 supports evaluation of the XFI protocol using Cortina CS4315 dual port 10G CDR. 10G data is carried over the XFI interface. The image below shows the connectivity of XFI interface.

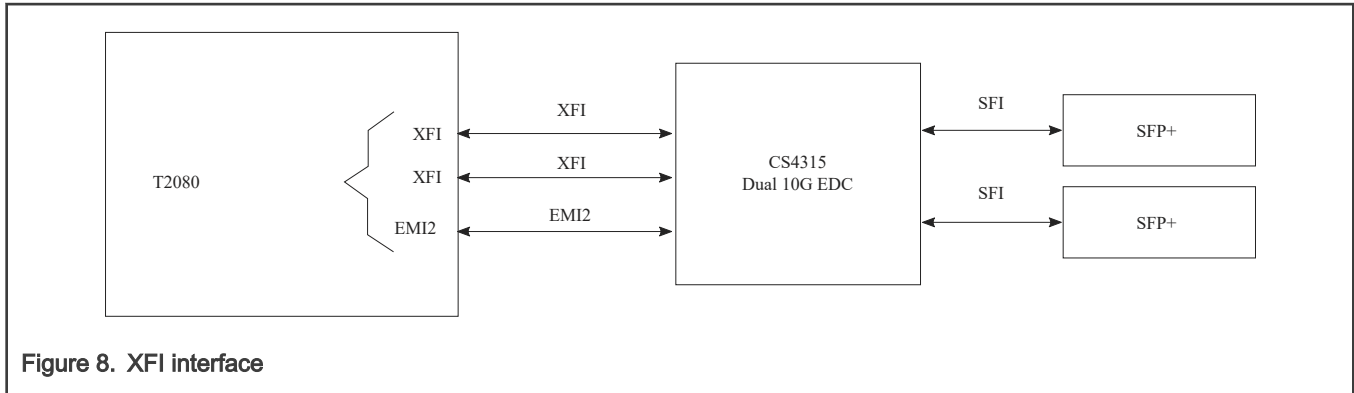

Figure 8. XFI interface

2.6.3 XFI 10GBase-T port support

The T2080 only supports evaluation of the XFI protocol using dual Aquantia AQR113C 10GBase-T PHYs. 10G data is carried over the XFI interface. The image below shows the connectivity of XFI interface.

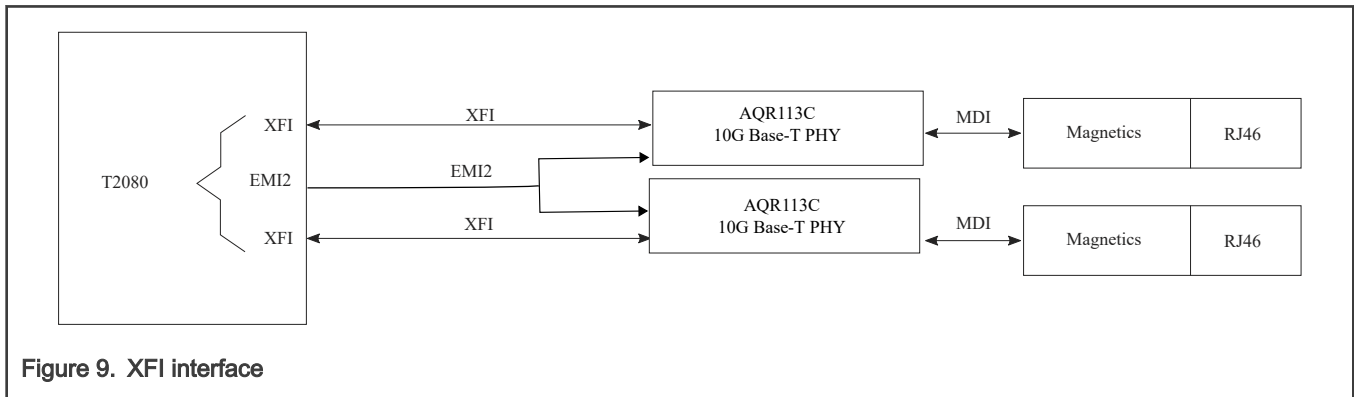

Figure 9. XFI interface

2.6.4 SATA support

SATA is evaluated using the two onboard SATA headers, by selecting a SATA-supporting SerDes protocol.

2.7 Ethernet controllers

The T2080 supports two Ethernet Controllers (EC), which can connect to Ethernet PHYs using MII or RGMII protocols. On the T2080RDB-PC, the EC1 and EC2 ports only operate in RGMII mode. Both ports connect to Realtek RTL8211 PHYs.

The image below shows the connectivity of EC1/EC2 interface.

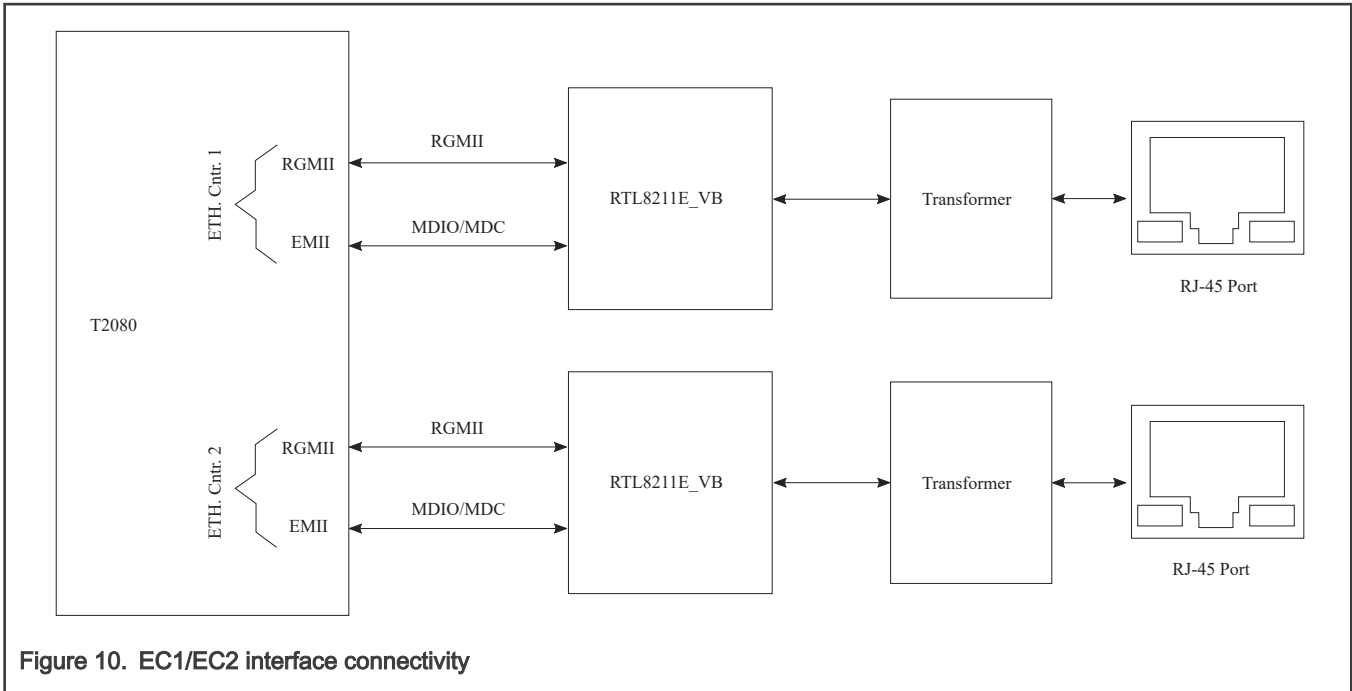

Figure 10. EC1/EC2 interface connectivity

2.8 Ethernet Management Interface

The T2080 has two Ethernet Management Interfaces (EMI), both powered by LVDD. However, EMI2 is only used with XFI-based PHYs, which uses 1.2 V pull-up. EMI1 is used with all other non-XFI-based PHYs, including the onboard RGMII PHYs. The image below shows the EMI hardware block.

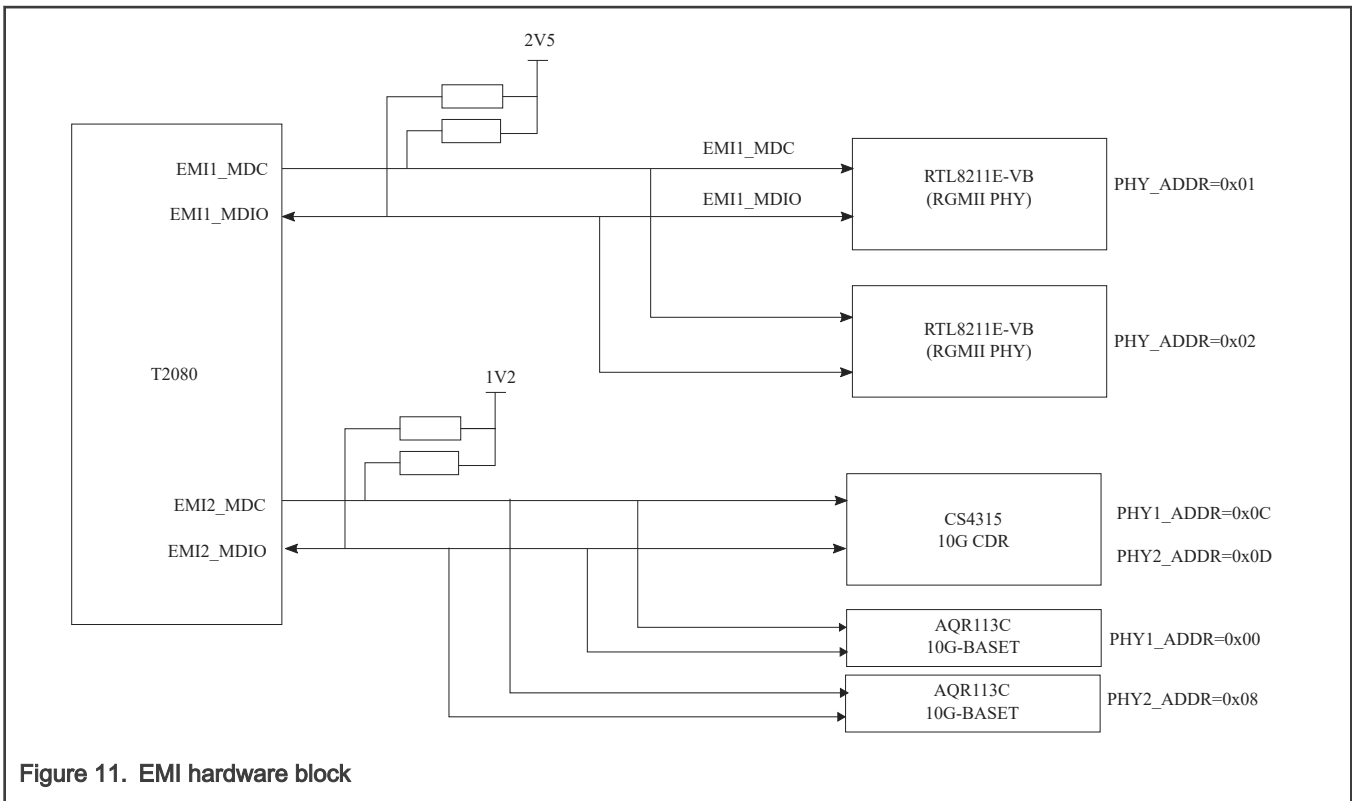

Figure 11. EMI hardware block

2.9 I2C

The T2080 device supports up to four I2C buses, in order to make the I2C resources equally available to both local and remote systems. The T2080RDB-PC uses I2C1 port to access onboard devices, such as DDR3 DIMM, RTC, I2C EEPROM, clock generator, thermal sensor (ADT7481), and core power regulator (LTC3882). The I2C2 bus uses multiplexers to partition the I2C bus into several subbuses, called channels. Two SFP+ optics use channel 0-1 and the PCIe SLOT use channel 3.

The image below shows the I2C subsystem.

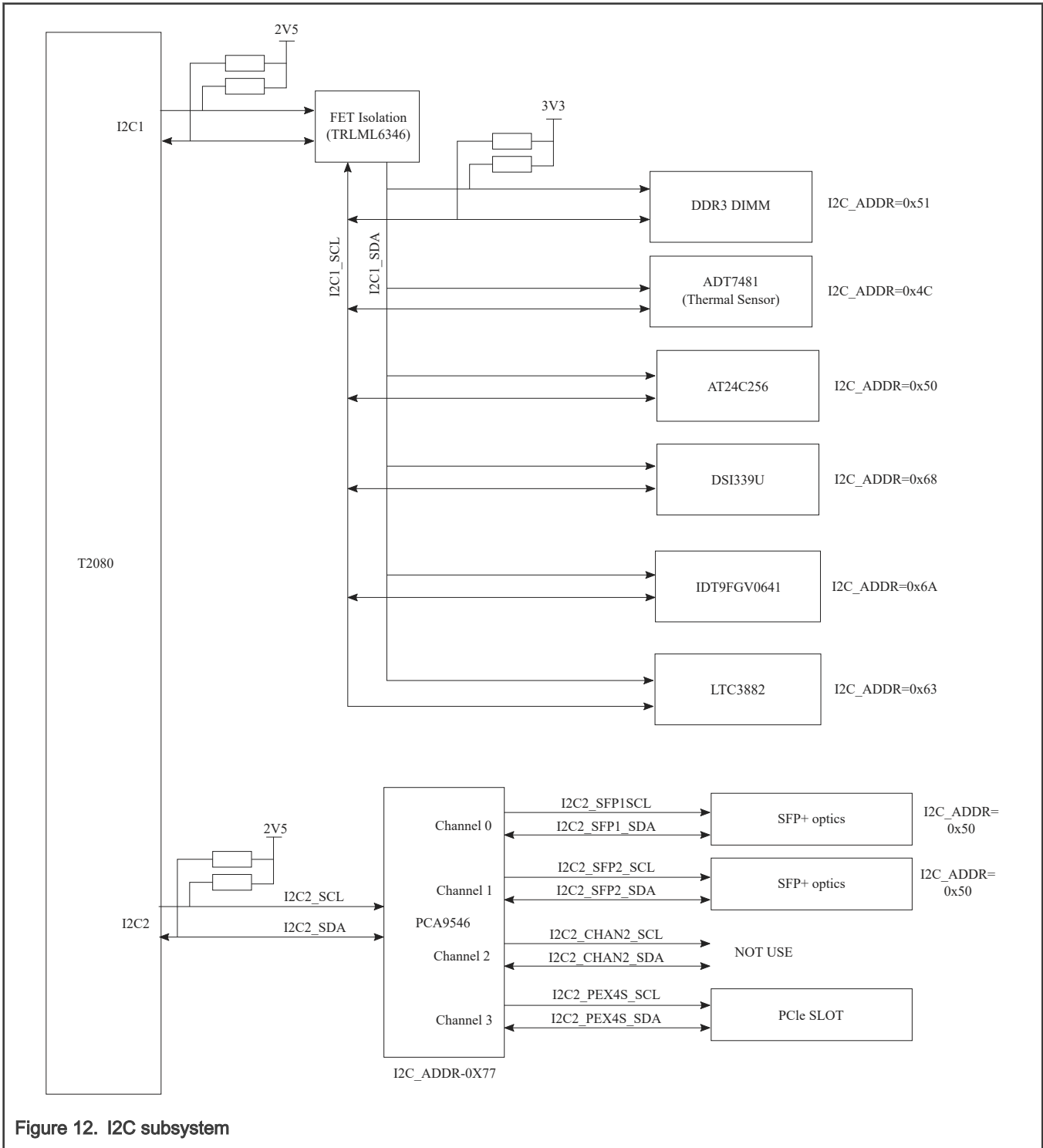

Figure 12. I2C subsystem

2.10 SPI interface

The T2080RDB-PC Serial Peripheral Interface (SPI) pins are only used for onboard SPI device accessing various SPI memory devices.

2.11 Local bus

The T2080 Integrated Flash Controller (IFC), also known as the local bus, supports 32-bit addressing and 8 or 16-bit data widths for various devices to effectively manage all these resources with the maximum amount of performance and flexibility.

The image below shows an overview of the IFC bus.

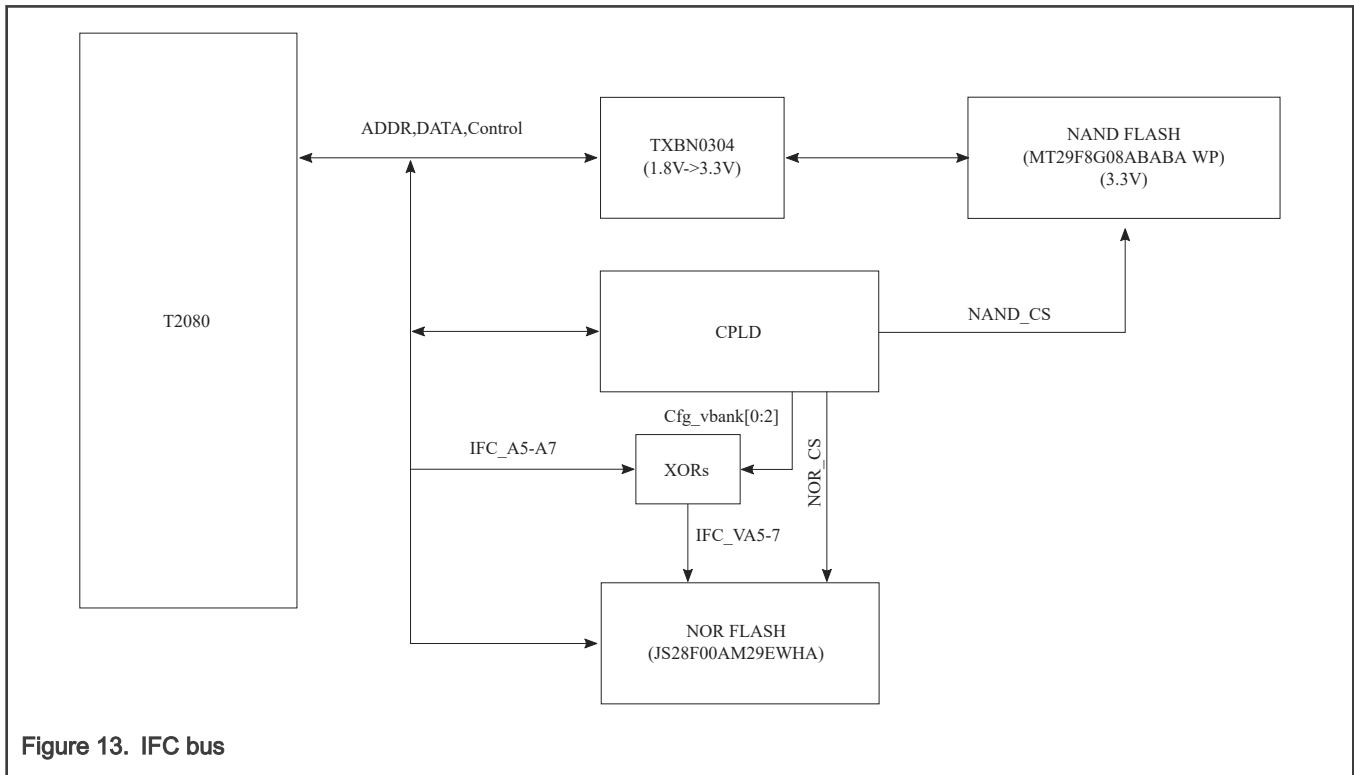

Figure 13. IFC bus

2.12 SDHC interface

The enhanced SD Host Controller (eSDHC) provides an interface between host system and SD cards. The Secure Digital (SD) card is designed to meet the security, capacity, performance, and environmental requirements, inherent in emerging audio and video consumer electronic devices. Booting from eSDHC interface is supported using the on-chip ROM of the processor.

On T2080RDB-PC, a single connector is used for MicroSD memory cards, as shown in the image below.

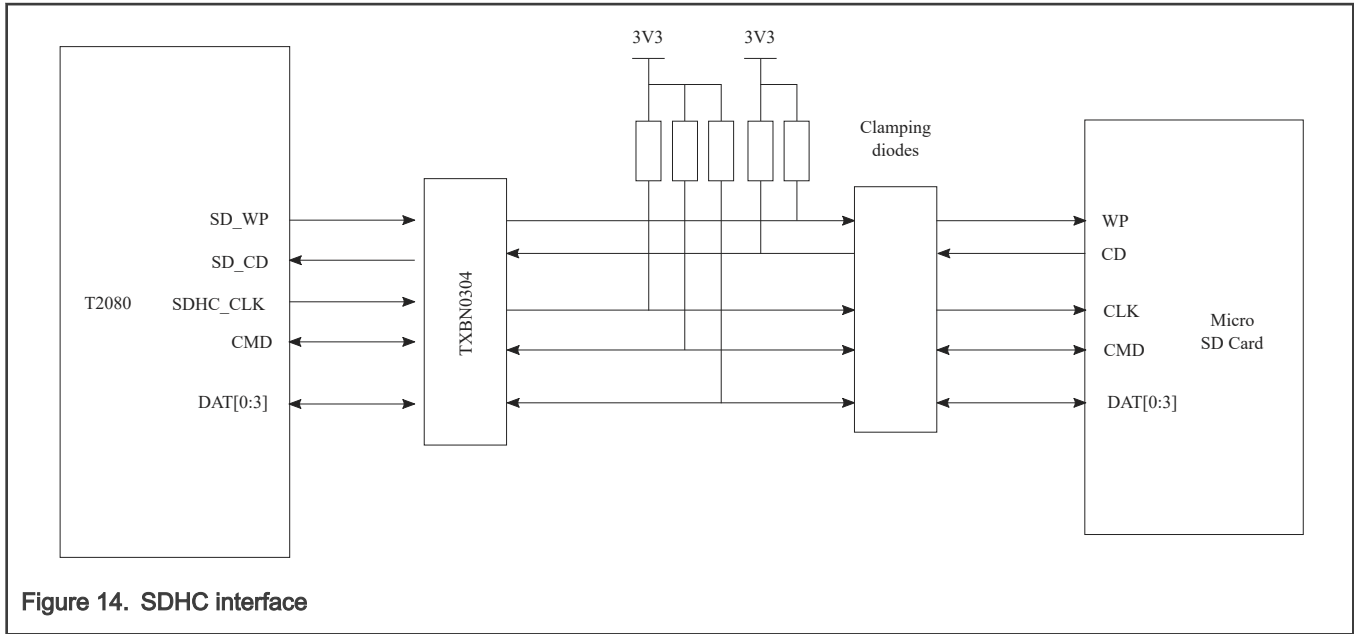

Figure 14. SDHC interface

2.13 USB interface

The T2080RDB-PC systems have two integrated USB 2.0 controllers, that allow direct connection to USB ports with appropriate protection circuitry and power supplies.

The board features are:

- High speed (480 Mbit/s), full-speed (12 Mbit/s), and low-speed (1.5 Mbit/s) operation
- Host mode
- Dual stacked Type A connection

The USB ports connect to a standard Type A connector (USB1 and USB2) for compatibility with most USB peripherals.

Power for the ports is provided by a MIC2506YM, which supplies 5 V at up to 1 A per port. The power enable and power-fault-detect pins are connected directly to the T2080 for individual port management.

The image below shows how the USB connectivity is implemented on the T2080RDB-PC.

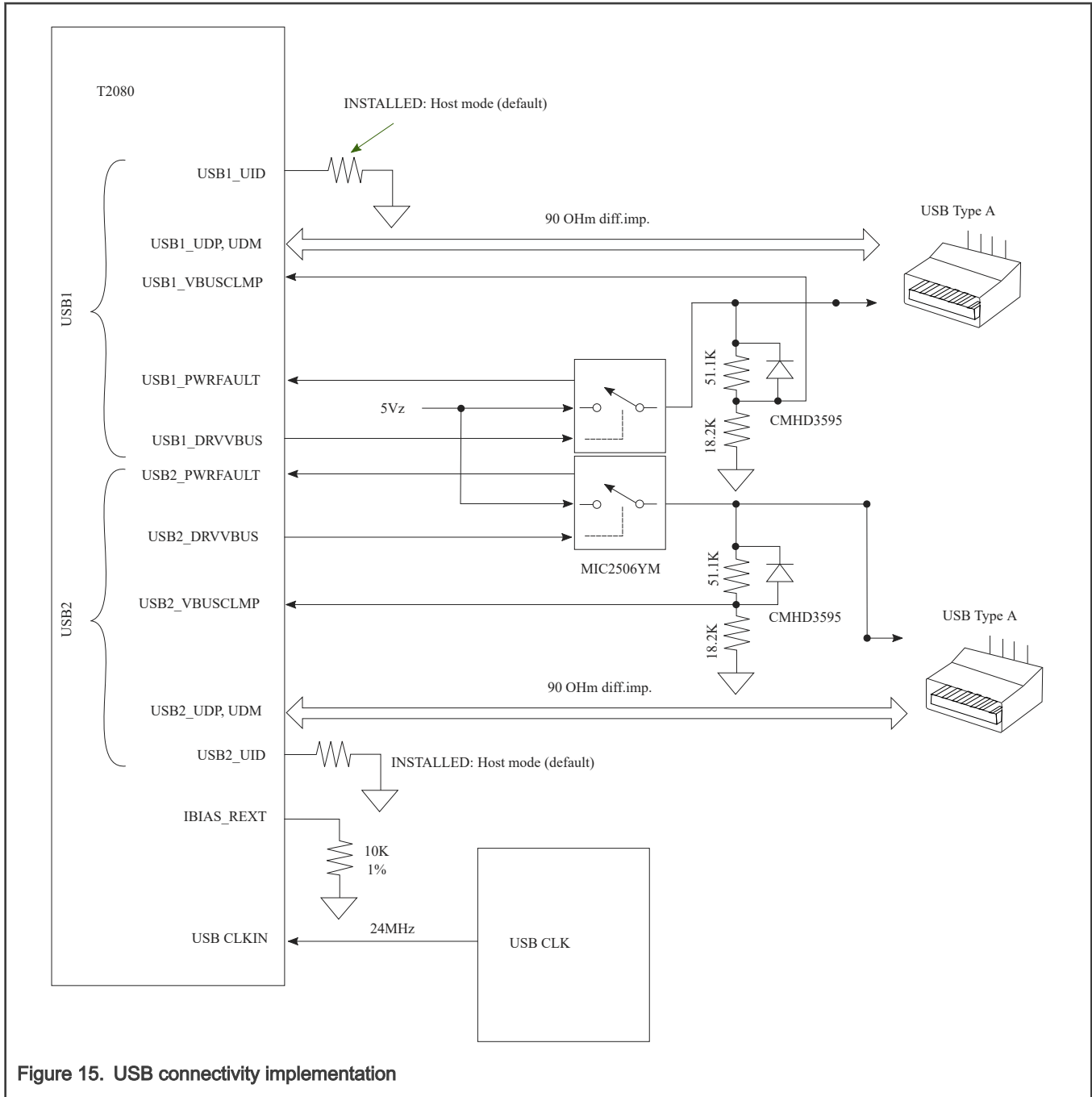

Figure 15. USB connectivity implementation

2.14 RS-232

The T2080 processor has two UART controllers, which provide an RS-232 standard interconnection between the board and an external host. The serial connection is typically configured to run at 11.5 Kbit/s.

Each UART supports:

- Full-duplex operation
- Software-programmable baud generators
- Software-selectable serial interface data format, that includes:
 - Data length

- Parity
- 1/1.5/2 STOP bit
- Baud rate
- Overrun, parity, and framing error detection

The UART ports are routed to 3PIN connectors, as shown in the image below.

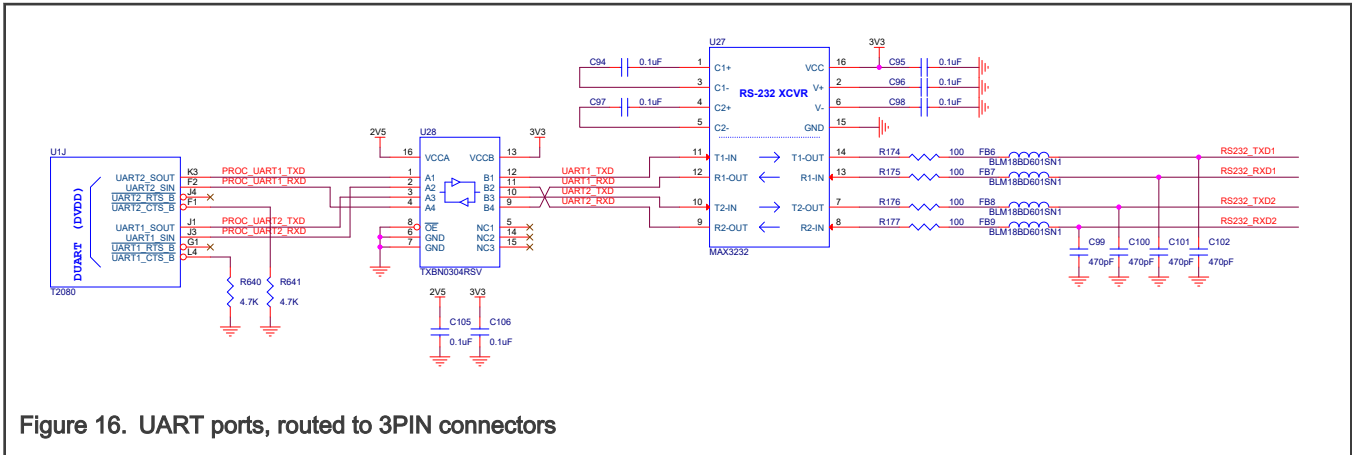

Figure 16. UART ports, routed to 3PIN connectors

The table below shows the connection setting for the UART 3pin connector to DB9 female cable connection.

Table 4. PIN3 to DB9 connection setting

3PIN connector	RS-232 signal	DB9 female pin number
1	TXD	2
2	GND	5
3	RXD	3

Before powering up the T2080RDB card, configure the serial port of the attached computer with the following values:

- Data rate: 115200 bit/s
- Number of data bits: 8
- Parity: None
- Number of stop bits: 1
- Flow control: Hardware/None

2.15 JTAG/COP port

The common on-chip processor (COP) is a part of the JTAG module of T2080 and is implemented as a set of additional instructions and logic. This port can connect to a dedicated emulator for extensive system debugging. Several third-party emulators in the market can connect to the host computer through the Ethernet port, USB port, parallel port, or RS-232. A typical setup using a USB port emulator is shown in the image below.

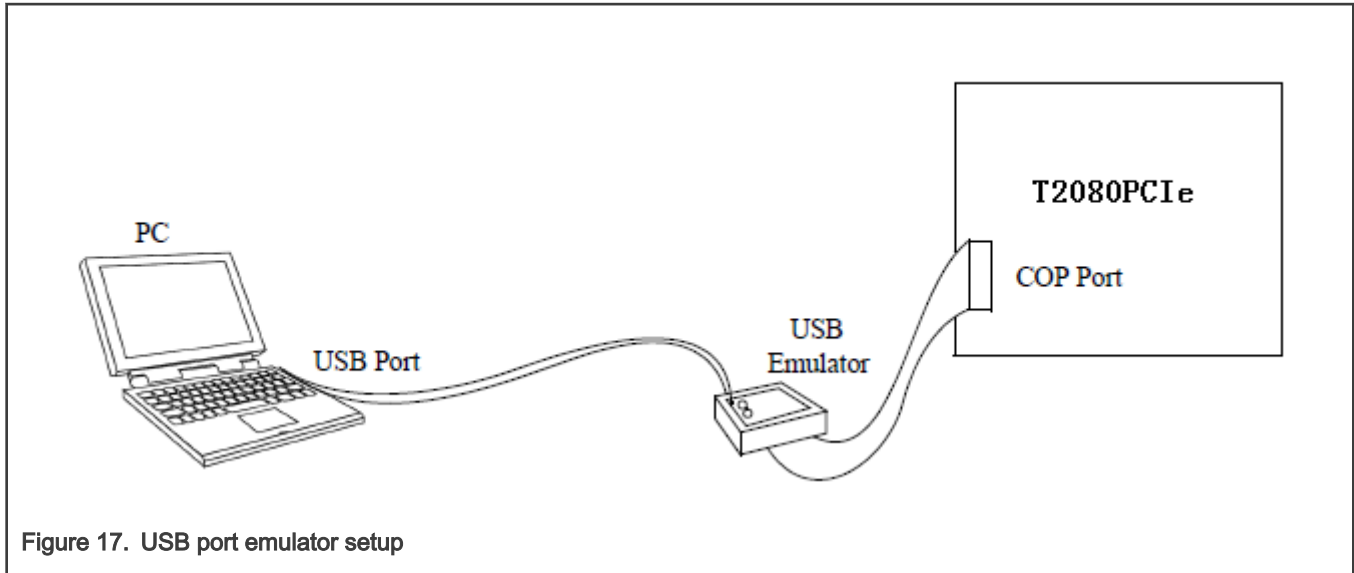

Figure 17. USB port emulator setup

The 16-pin generic header connector carries the COP/JTAG signals and the additional signals for system debugging. The pin-out of this connector is shown in the image below.

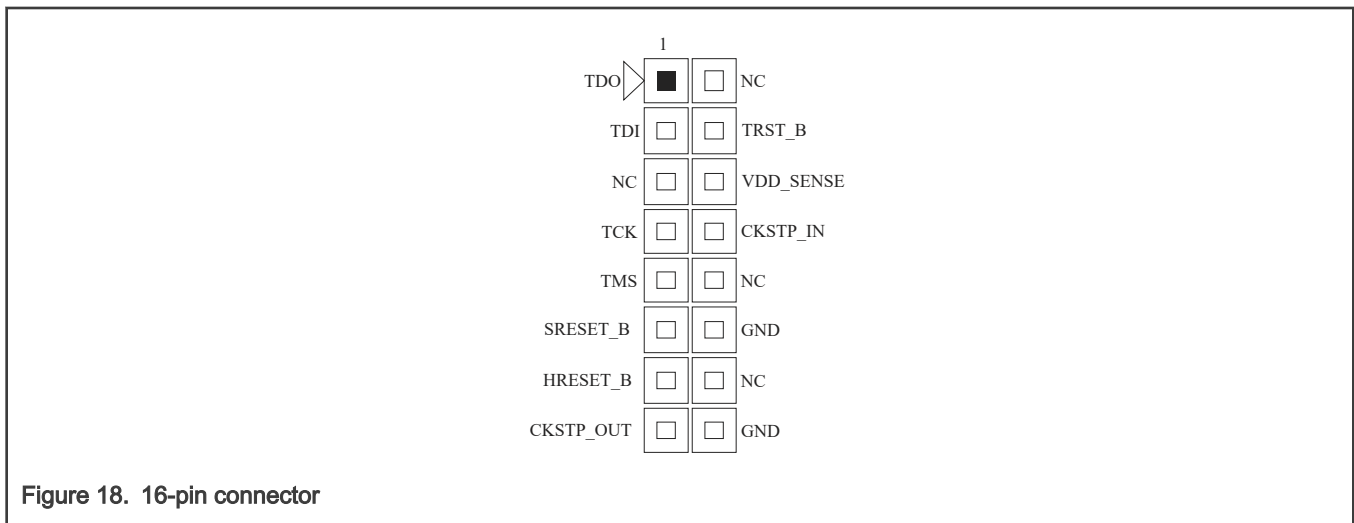

Figure 18. 16-pin connector

The table below displays the connections made from the T2080RDB-PC COP connector.

Table 5. Connections made from the T2080RDB-PC COP connector

Pin no.	Signal name	Connection
1	TDO	Connected directly between the processor and JTAG/COP connector.
2	NC	Not connected.
3	TDI	Connected directly between the processor and JTAG/COP connector.
4	TRST	Routed to the RESET PLD. TRST to the processor is generated from the PLD.
5	NC	Not connected.
6	VDD_SENSE	Pulled to 3.3 V using a 10 Ohm resistor.
7	TCK	Connected directly between the processor and JTAG/COP connector.

Table continues on the next page...

Table 5. Connections made from the T2080RDB-PC COP connector (continued)

Pin no.	Signal name	Connection
8	CKSTP_IN	Connected directly between the processor and JTAG/COP connector.
9	TMS	Connected directly between the processor and JTAG/COP connector.
10	NC	Not connected.
11	SRESET	Routed to the RESET PLD. SRESET to the processor is generated from the PLD.
12	GND	Connected to guard.
13	HRESET	Routed to the RESET PLD. HRESET to the processor is generated from the PLD.
14	KEY	Not connected.
15	CKSTP_OUT	Connected directly between the processor and JTAG/COP connector.
16	GND	Connected to guard.

2.16 Connectors, Headers, Jumper, Push buttons, and LEDs

This section explains:

- [Connectors](#)
- [Headers](#)
- [Jumper](#)
- [Push buttons](#)
- [LEDs](#)

2.16.1 Connectors

[Table 6](#) lists the various connectors on the T2080RDB-PC platform.

Table 6. Connectors on the T2080RDB-PC platform

Reference designators	Used for	Notes
J28	6-pin EPS connector	-
J2	MicroSD card	-
J20	PCIe x4 slot	Intended use is for PCIe cards that are 25 W or less.
J21, J22	SATA	-
J43	TDM Riser card	-
J36, J37	Ethernet ports	RGMII -> Copper
J17, J18	Ethernet ports	10GBase-T
J13, J15	Ethernet ports	10G optics
J41	Dual Type A USB	-
J35 (2 ports)	UART	-
J8	Battery holder	-
J1	SODIM	-

Table continues on the next page...

Table 6. Connectors on the T2080RDB-PC platform (continued)

Reference designators	Used for	Notes
J22, J23	FXS ports	-
J24	FXO port	-
J34	CPU fan	-
J33, J44-J46	Shelf FAN	-

2.16.2 Headers

The table below lists the various headers on the T2080RDB-PC platform.

Table 7. Headers on the T2080RDB-PC platform

Reference designators	Used for	Notes
J24	Altera header	Used for programming the Altera CPLD devices.
J26	LTC3882 header	Used for programming the LTC3882.
J3	COP/JTAG	Used for debugging the T2080.

2.16.3 Jumper

The table below describes how the push Jumper is used on the T2080RDB-PC platform.

Table 8. Jumper on the T2080RDB-PC platform

Reference designator	Description	Status 1	Status 2
J29	Battery selection for VDD_LP source	Mounted: Battery acts as a VDD_LP input source	Unmounted: Battery is disconnected
J30	Tamper detection pin powered selection	1-2: Tamper detection pin is powered on	2-3: Tamper detection pin is powered off
J10	PROG_SFP selection	Mounted: Fuse programming	Unmounted: Normally operate
J25	Not used	-	-
J38	SD/TF card voltage selection	1-2: TF card works at 3.3 V	2-3: TF card works at 1.8 V

2.16.4 Push buttons

The table below describes what the push buttons are used for on the T2080RDB-PC platform.

Table 9. Push buttons on T2080RDB-PC platform

Reference designators	Used for	Notes
SW5	Reset	Used for resetting the whole board.
SW4	Power on/off	Used for turning the power on or off.

2.16.5 LEDs

[Table 10](#) lists all the LEDs on the T2080RDB-PC front plate.

Table 10. LEDs on the T2080RDB-PC front plate

LEDs	Used for	Controlled by
D12	Power on	+3.3 V rail
D4	SFP1_LED0	CPLD
D5	SFP1_LED1	CPLD
D6	SFP2_LED0	CPLD
D7	SFP2_LED1	CPLD

2.17 Temperature

The T2080 has a thermal diode attached to the die, allowing direct temperature measurement. These pins are connected to an ADT7481 3 channel thermal monitor. One channel monitors the T2080 and another channel monitors the C29x, which allows direct reading of the temperature of the die and is accurate to ± 1 °C. The third channel of the ADT7481 measures the ambient (board) temperature.

The ADT7481 temperature warning and alarm signals are connected to the CPLD for monitoring. CPLD uses these signals to adjust CPU FAN speed and protect the CPU from over-temperature failure.

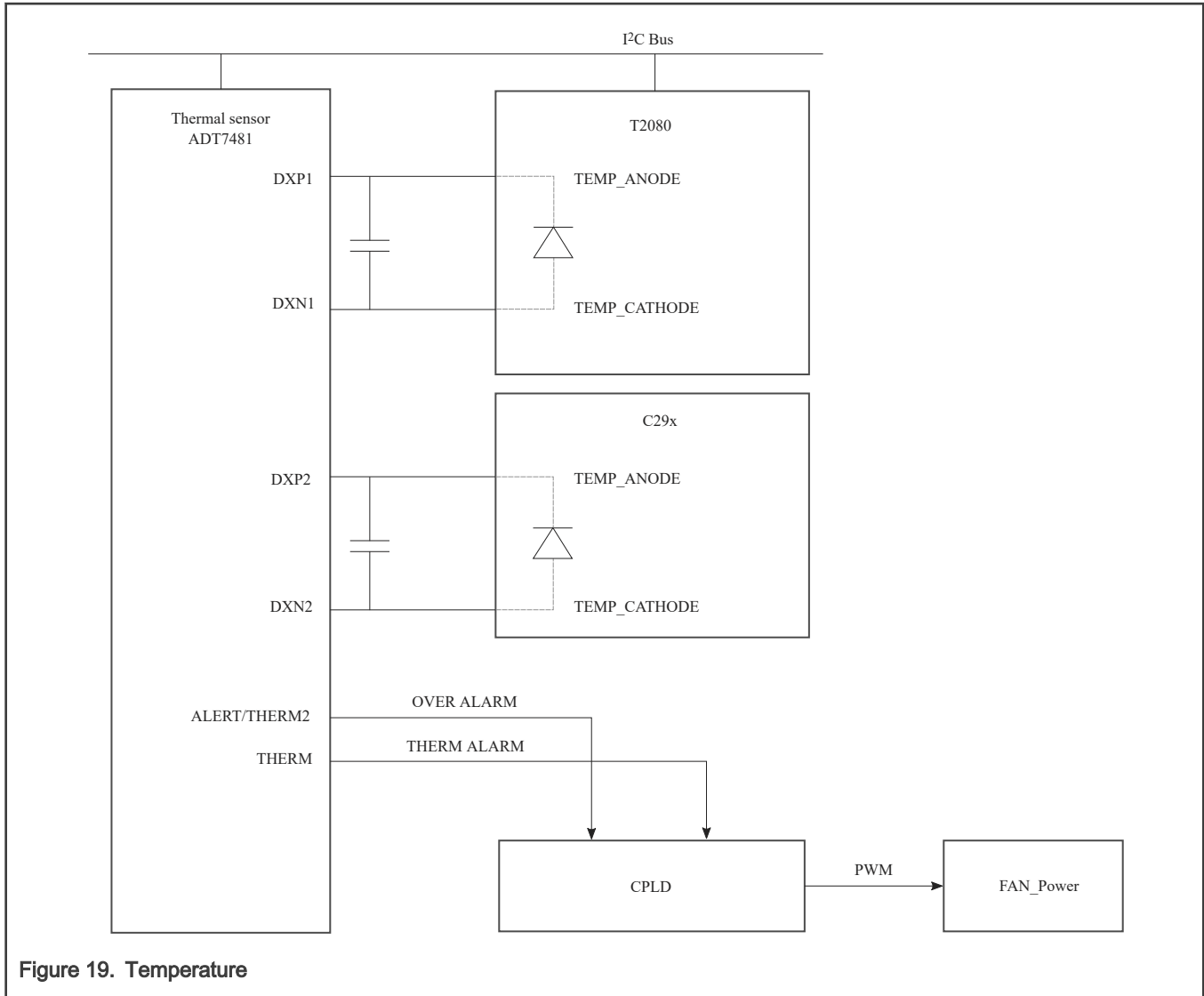

Figure 19. Temperature

2.18 DIP switch definition

The T2080RDB-PC board has user selectable switches, for evaluating different boot configurations and other special configurations for this device.

This configuration allows either the switch or the CPLD register to set the POR pin. The CPLD register allows software to override the pin remotely when the board is in the board farm.

In order to use the CPLD override option, software sets an override bit, that allows the CPLD to override the switch setting during power-on reset.

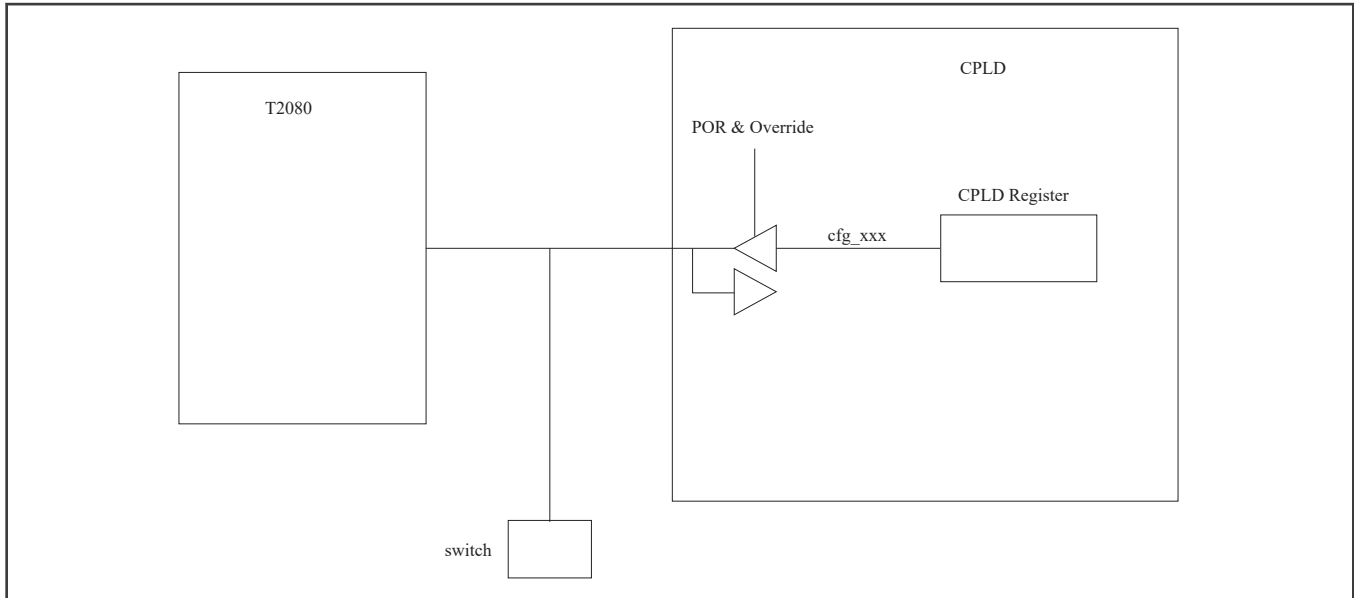

Figure 20. DIP switch definition

Table 11 shows how POR configuration is done through switches.

Table 11. POR configuration through switches

Switch	Signal name	Pin name	Signal meaning	Setting
SW1[1:8]	cfg_rcw_src[0:7]	IFC_AD[8:15]	Reset Configuration word source. For details, see <i>T2080 Integrated Multicore Communications Processor Family Reference Manual</i> (document T2080RM)	NOR boot: 00010011_1 NAND boot: 10000010_1 SPI boot: 00100010_1 SD boot: 00100000_0
SW2[1]	cfg_rcw_src[8]	IFC_CLE	Reset Configuration word source	For details, see <i>T2080 Integrated Multicore Communications Processor Family Reference Manual</i> (document T2080RM)
SW2[2]	cfg_ifc_te	IFC_TE	IFC external transceiver enable polarity select	0: IFC drives logic 1 for TE assertion 1: IFC drives logic 0 for TE assertion
SW2[3]	cfg_pll_config_sel_b	IFC_A18	Reserved	Reserved
SW2[4]	cfg_por_ainit	IFC_A19	Reserved	Reserved
SW2[5:6]	cfg_svr[0:1]	IFC_A[16:17]	Reserved	Reserved
SW2[7]	cfg_dram_type	IFC_A21	DRAM type selection	1: DDR3L (1.35 V)
SW2[8]	cfg_rsp_dis	IFC_AVD	Reserved	Reserved
SW3[1]	cfg_eng_use0	IFC_WE0	Sys_clock selection	1: Single sys_clk is selected

Table continues on the next page...

Table 11. POR configuration through switches (continued)

Switch	Signal name	Pin name	Signal meaning	Setting
SW3[2:3]	cfg_eng_use[1:2]	Reserved	Reserved	-
SW3[4]	BOOT_FLASH_SEL	-	Boot flash selection	SW3[4] = 0 for NOR boot SW3[4] = 1 for NAND boot See note ¹
SW3[5:7]	CFG_VBANK[0:2]	-	NOR flash bank select	000: bank0 100: bank4 See note ²
SW3[8]	TEST_SEL_N	TEST_SEL_B	-	1:T2080

1. For SW3[4]: BOOT_FLASH_SEL, it can act as boot flash selection, when BOOT_FLASH_SEL=1, NOR flash is boot flash or NAND flash is boot flash.
2. SW3[5:7] can be used to change the starting address for the memory banks. The NOR flash memory is divided into eight memory banks with 16 MB size each. Eight different U-Boot images can be programmed into each memory bank. When NOR flash is selected as boot flash (CS0 is connected to NOR flash by setting SW3[4] to ON, RCW[0:8] is set to 0_0111_xxxx using SW1[1:8] and SW2[1]), different U-Boot image can be selected to boot up the board, by setting SW3[5:7].

Chapter 3

CPLD Specification

This section explains the CPLD registers.

3.1 Register descriptions

3.1.1 CPLD Memory map

T2080_RDB base address: 0h

Offset	Register	Width (In bits)	Access	Reset value
0h	Chip ID1 register (CHIPID1)	8	RO	55h
1h	Chip ID2 register (CHIPID2)	8	RO	AAh
2h	Hardware version register (HWVER)	8	RO	See description
3h	Software version register (SWVER)	8	RO	See description
10h	Reset control register (RSTCON)	8	W1C	See description
11h	Flash control and status register (FLHCSR)	8	RW	See description
12h	Thermal control and status register (THMCSR)	8	RW	See description
13h	Panel LED control and status register (LEDCSR)	8	RW	00h
14h	SFP+ control and status register (SFPCSR)	8	RW	See description
15h	Miscellanies control and status register (MISCCSR)	8	RW	See description
16h	Boot configuration override register (BOOTOR)	8	RW	00h
17h	Boot configuration register 1 (BOOTCFG1)	8	RW	00h
18h	Boot configuration register 2 (BOOTCFG2)	8	RW	00h

3.1.2 Chip ID1 register (CHIPID1)

Offset

Register	Offset
CHIPID1	0h

Diagram

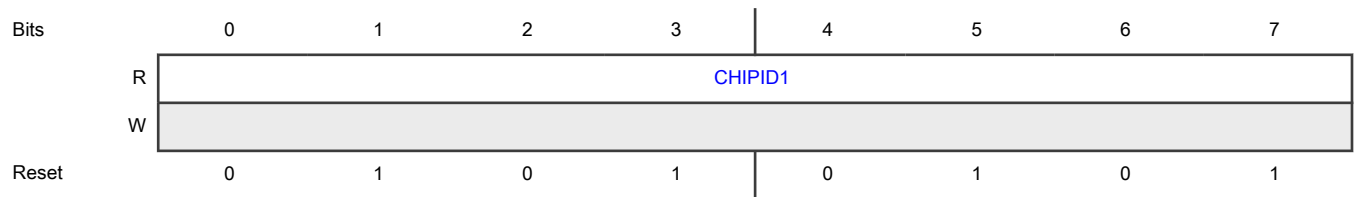

Fields

Field	Function
0-7 CHIPID1	CHIPID1 0x55, Identification of the CPLD image.

3.1.3 Chip ID2 register (CHIPID2)

Offset

Register	Offset
CHIPID2	1h

Diagram

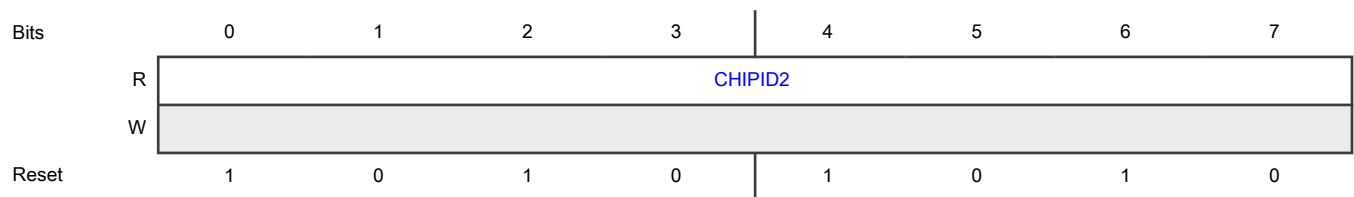

Fields

Field	Function
0-7 CHIPID2	CHIPID2 0xaa, Identification of the CPLD image.

3.1.4 Hardware version register (HWVER)

Offset

Register	Offset
HWVER	2h

Function

Hardware version register.

Diagram

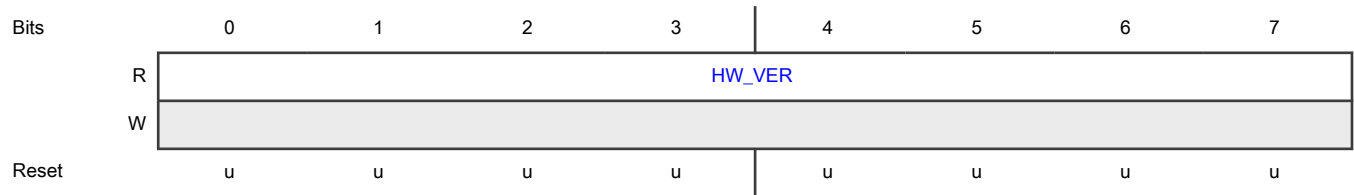

Fields

Field	Function
0-7 HW_VER	<p>HW_VER</p> <p>The version field of the hardware board.</p> <ul style="list-style-type: none"> • Rev C: 0X1 • Rev D: 0X0 • Rev E: 0X2 • Rev F: 0X3

3.1.5 Software version register (SWVER)

Offset

Register	Offset
SWVER	3h

Diagram

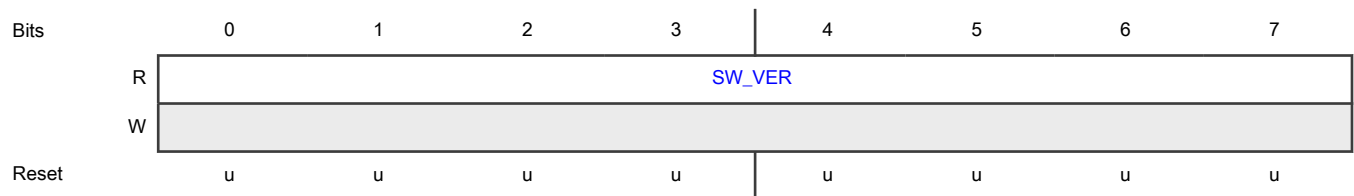

Fields

Field	Function
0-7 SW_VER	<p>SW_VER</p> <p>The version field of the CPLD software.</p>

3.1.6 Reset control register (RSTCON)

Offset

Register	Offset
RSTCON	10h

Diagram

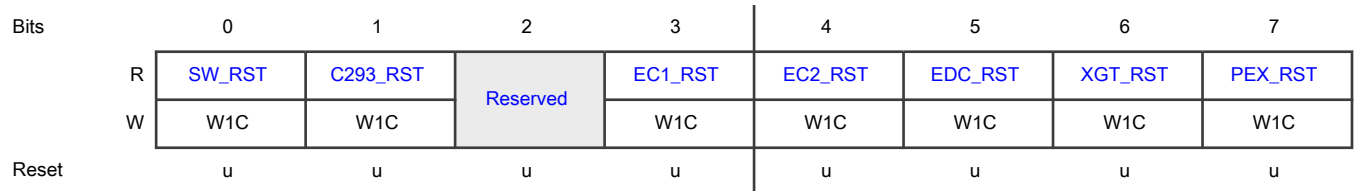

Fields

Field	Function
0 SW_RST	SW_RST 0: No reset occurs. 1: Writing logic 1 generates whole board reset# signal; this bit can auto clear.
1 C293_RST	C293_RST 0: No reset occurs. 1: Writing logic 1 generates C293 Coprocessor reset# signal; this bit can auto clear.
2 —	-
3 EC1_RST	EC1_RST 0: No reset occurs. 1: Writing logic 1 generates RGMII PHY1 (RTL82111E-VB) reset# signal; this bit can auto clear.
4 EC2_RST	EC2_RST 0: No reset occurs. 1: Writing logic 1 generates RGMII PHY2 (RTL82111E-VB) reset# signal; this bit can auto clear.
5 EDC_RST	EDC_RST 0: No reset occurs. 1: Writing logic 1 generates 10GEDC PHY(CS4315) reset# signal; this bit can auto clear.
6 XGT_RST	XGT_RST 0: No reset occurs.

Table continues on the next page...

Table continued from the previous page...

Field	Function
	1: Writing logic 1 generates 10GBase-T PHY (AQR113C) reset# signal; this bit can auto clear.
7 PEX_RST	PEX_RST 0: No reset occurs 1: Writing logic 1 generates PCIe x4 slot reset# signal; this bit can auto clear.

3.1.7 Flash control and status register (FLHCSR)

Offset

Register	Offset
FLHCSR	11h

Diagram

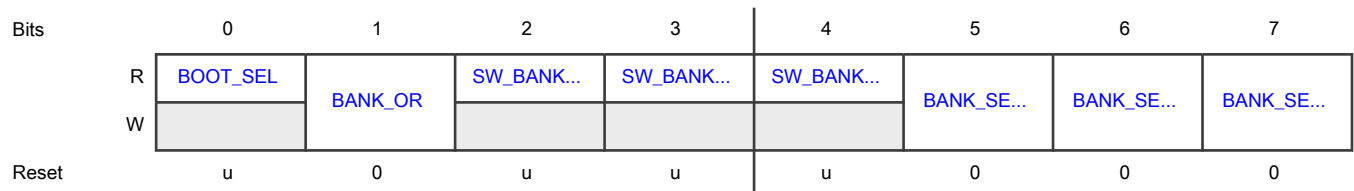

Fields

Field	Function
0 BOOT_SEL	BOOT_SEL 0: Boot from 16-bit NOR flash. 1: Boot from 8-bit NAND flash.
1 BANK_OR	BANK_OR 0: NOR flash bank select from CPLD override disable. 1: NOR flash bank select from CPLD override enable.
2 SW_BANK_SEL0	SW_BANK_SEL0 0: NOR flash bank select bit0 of switch status is 0. 1: NOR flash bank select bit0 of switch status is 1.
3 SW_BANK_SEL1	SW_BANK_SEL1 0: NOR flash bank select bit1 of switch status is 0. 1: NOR flash bank select bit1 of switch status is 1.

Table continues on the next page...

Table continued from the previous page...

Field	Function
4 SW_BANK_SEL 2	SW_BANK_SEL2 0: NOR flash bank select bit2 of switch status is 0. 1: NOR flash bank select bit2 of switch status is 1.
5 BANK_SEL0	BANK_SEL0 0: NOR flash bank select bit0 set 0. 1: NOR flash bank select bit0 set 1.
6 BANK_SEL1	BANK_SEL1 0: NOR flash bank select bit1 set 0. 1: NOR flash bank select bit1 set 1
7 BANK_SEL2	BANK_SEL2 0: NOR flash bank select bit2 set 0. 1: NOR flash bank select bit2 set 1.

3.1.8 Thermal control and status register (THMCSR)

Offset

Register	Offset
THMCSR	12h

Diagram

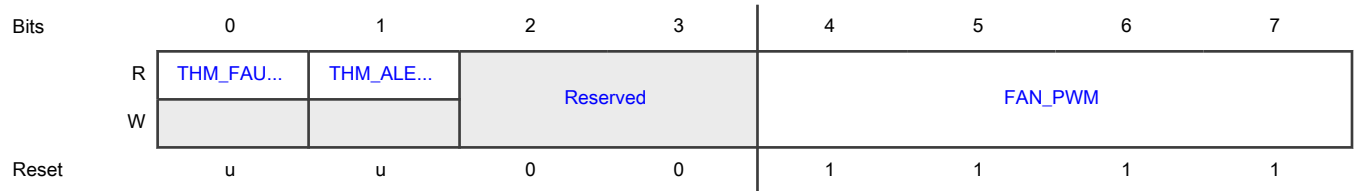

Fields

Field	Function
0 THM_FAULT	THM_FAULT 0: Thermal sensor no fault occurs. 1: Thermal sensor fault output.
1	THM_ALERT

Table continues on the next page...

Table continued from the previous page...

Field	Function
THM_ALERT	0: Thermal sensor no alert occurs. 1: Thermal sensor alert output.
2-3 —	-
4-7 FAN_PWM	FAN_PWM 0000: PWM duty cycle is 0 %, fan stop running. 0001 - 1110: PWM duty cycle is 6.7 % - 93.3%, fan speed control. 1111: PWM duty cycle is 100 %, fan full speed.

3.1.9 Panel LED control and status register (LEDCSR)

Offset

Register	Offset
LEDCSR	13h

Diagram

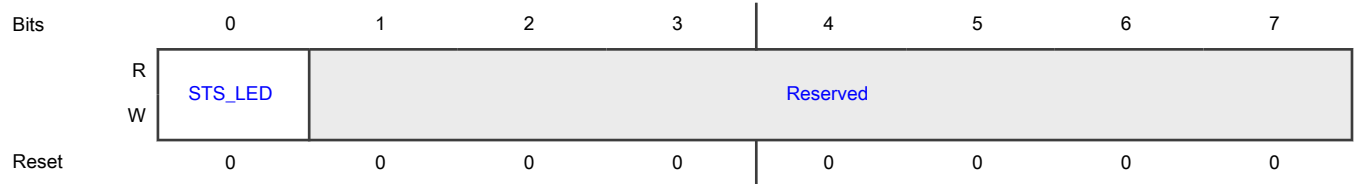

Fields

Field	Function
0 STS_LED	STS_LED 0: Panel STATUS LED on. 1: Panel STATUS LED flash at 0.5 s.
1-7 —	-

3.1.10 SFP+ control and status register (SFPCSR)

Offset

Register	Offset
SFPCSR	14h

Diagram

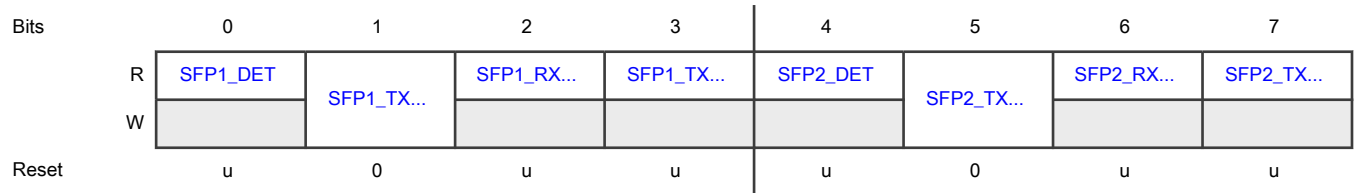

Fields

Field	Function
0 SFP1_DET	SFP1_DET 0: SFP+1 module not inserted 1: SFP+1 module inserted
1 SFP1_TXDIS	SFP1_TXDIS 0: SFP+1 TX enable 1: SFP+1 TX disable
2 SFP1_RXLOS	SFP1_RXLOS 0: SFP+1 RX LOS logic 0 1: SFP+1 RX LOS logic 1 (some SFP+ used as RXSD)
3 SFP1_TXFAIL	SFP1_TXFAIL 0: SFP+1 TX FAIL not occurs SFP+1 TX FAIL occurs
4 SFP2_DET	SFP2_DET 0: SFP+2 module not inserted 1: SFP+2 module inserted
5 SFP2_TXDIS	SFP2_TXDIS 0: SFP+2 TX enable 1: SFP+2 TX disable
6 SFP2_RXLOS	SFP2_RXLOS

Table continues on the next page...

Table continued from the previous page...

Field	Function
SFP2_RXLOS	0: SFP+2 RX LOS logic 0 1: SFP+2 RX LOS logic 1(some SFP+ used as RXSD)
7 SFP2_TXFAIL	SFP2_TXFAIL 0: SFP+2 TX FAIL not occurs 1: SFP+2 TX FAIL occurs

3.1.11 Miscellanies control and status register (MISCCSR)

Offset

Register	Offset
MISCCSR	15h

Diagram

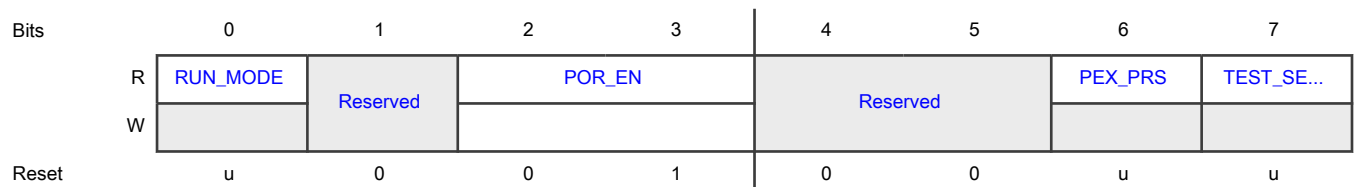

Fields

Field	Function
0 RUN_MODE	RUN_MODE 0: T2080RDB-PC runs as standalone mode 1: T2080RDB-PC runs as PCIe x4 add-in card
1 —	Reserved
2-3 POR_EN	11: Enable POR for software reset command
3-5 —	Reserved
6 PEX_PRS	PEX_PRS 0: PCIe x4 card not present

Table continues on the next page...

Table continued from the previous page...

Field	Function
	1: PCIe x4 card present
7 TEST_SEL_N	TEST_SEL_N 0: TEST_SEL_N pin status is 0 1: TEST_SEL_N pin status is 1

3.1.12 Boot configuration override register (BOOTOR)

Offset

Register	Offset
BOOTOR	16h

Diagram

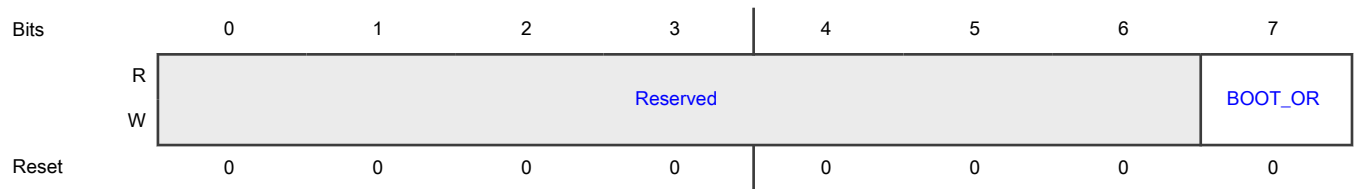

Fields

Field	Function
0-6 —	-
7 BOOT_OR	BOOT_OR 0: Boot configuration from CPLD overrides disable 1: Boot configuration from CPLD overrides enable

3.1.13 Boot configuration register 1 (BOOTCFG1)

Offset

Register	Offset
BOOTCFG1	17h

Diagram

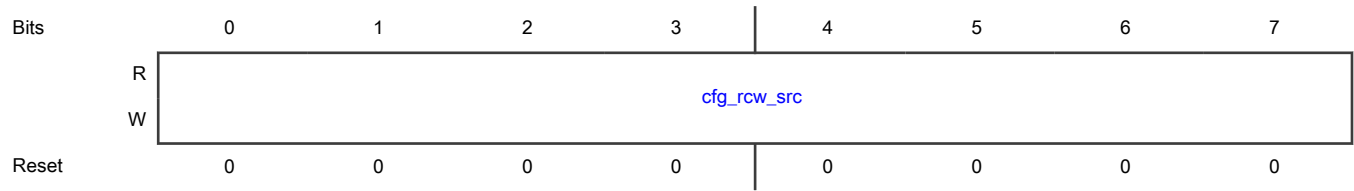

Fields

Field	Function
0-7 cfg_rcw_src	cfg_rcw_src
NOTE For details, see T2080 Integrated Multicore Communications Processor Family Reference Manual (document T2080RM).	

3.1.14 Boot configuration register 2 (BOOTCFG2)

Offset

Register	Offset
BOOTCFG2	18h

Diagram

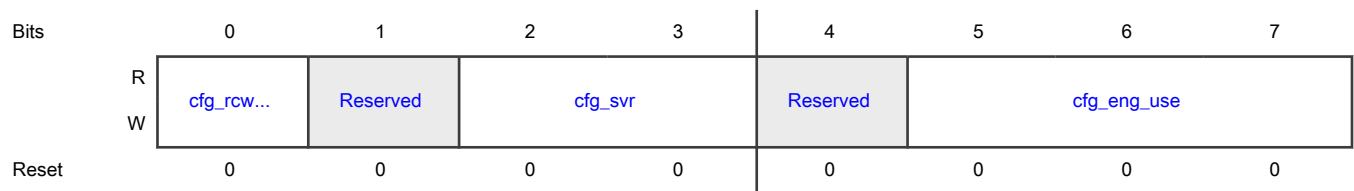

Fields

Field	Function
0 cfg_rcw_src8	cfg_rcw_src8 RCW source bit 8.
1 —	-
2-3 cfg_svr	cfg_svr cfg_svr bits for Power-on Reset using.
4	-

Table continues on the next page...

Table continued from the previous page...

Field	Function
—	
5-7 cfg_eng_use	cfg_eng_use cfg_eng_use bits for Power-on Reset using.

Appendix A

Revision history

The table below summarizes revisions to this document.

Table 12. Revision history

Revision	Date	Topic cross-reference	Change description
Rev. 1	08/2021	Block diagram	Updated Figure 2 .
		XFI 10GBase-T port support	Replaced AQR1202 PHY with AQR113C PHY in text and block diagram.
		Register descriptions	<ul style="list-style-type: none"> Updated Miscellanies control and status register (MISCCSR) for register bits 2 and 3. Updated bit [0-7] description of Hardware version register (HWVER).
		Jumper	Updated jumper for PROG_SFP selection in Table 8 .
		I2C	Updated Figure 12 for LTC3882 device detail.
		Ethernet Management Interface	Updated Figure 11 for AQR113C PHYs detail.
		Power	Updated Figure 3 to add x2 FDMF5820DC devices.
		Reset	Replaced AQR1202 PHY with x2 AQR113C PHYs in Figure 4 .
Rev. 0	06/2015	-	Initial public release.

How To Reach Us

Home Page:

nxp.com

Web Support:

nxp.com/support

Limited warranty and liability — Information in this document is provided solely to enable system and software implementers to use NXP products. There are no express or implied copyright licenses granted hereunder to design or fabricate any integrated circuits based on the information in this document. NXP reserves the right to make changes without further notice to any products herein.

NXP makes no warranty, representation, or guarantee regarding the suitability of its products for any particular purpose, nor does NXP assume any liability arising out of the application or use of any product or circuit, and specifically disclaims any and all liability, including without limitation consequential or incidental damages. "Typical" parameters that may be provided in NXP data sheets and/or specifications can and do vary in different applications, and actual performance may vary over time. All operating parameters, including "typicals," must be validated for each customer application by customer's technical experts. NXP does not convey any license under its patent rights nor the rights of others. NXP sells products pursuant to standard terms and conditions of sale, which can be found at the following address: nxp.com/SalesTermsandConditions.

Right to make changes - NXP Semiconductors reserves the right to make changes to information published in this document, including without limitation specifications and product descriptions, at any time and without notice. This document supersedes and replaces all information supplied prior to the publication hereof.

Security — Customer understands that all NXP products may be subject to unidentified or documented vulnerabilities. Customer is responsible for the design and operation of its applications and products throughout their lifecycles to reduce the effect of these vulnerabilities on customer's applications and products. Customer's responsibility also extends to other open and/or proprietary technologies supported by NXP products for use in customer's applications. NXP accepts no liability for any vulnerability. Customer should regularly check security updates from NXP and follow up appropriately. Customer shall select products with security features that best meet rules, regulations, and standards of the intended application and make the ultimate design decisions regarding its products and is solely responsible for compliance with all legal, regulatory, and security related requirements concerning its products, regardless of any information or support that may be provided by NXP. NXP has a Product Security Incident Response Team (PSIRT) (reachable at PSIRT@nxp.com) that manages the investigation, reporting, and solution release to security vulnerabilities of NXP products.

NXP, the NXP logo, NXP SECURE CONNECTIONS FOR A SMARTER WORLD, COOLFLUX, EMBRACE, GREENCHIP, HITAG, ICODE, JCOP, LIFE, VIBES, MIFARE, MIFARE CLASSIC, MIFARE DESFire, MIFARE PLUS, MIFARE FLEX, MANTIS, MIFARE ULTRALIGHT, MIFARE4MOBILE, MIGLO, NTAG, ROADLINK, SMARTLX, SMARTMX, STARPLUG, TOPFET, TRENCHMOS, UCODE, Freescale, the Freescale logo, AltiVec, CodeWarrior, ColdFire, ColdFire+, the Energy Efficient Solutions logo, Kinetis, Layerscape, MagniV, mobileGT, PEG, PowerQUICC, Processor Expert, QorIQ, QorIQ Qonverge, SafeAssure, the SafeAssure logo, StarCore, Symphony, VortiQa, Vybrid, Airfast, BeeKit, BeeStack, CoreNet, Flexis, MXC, Platform in a Package, QUICC Engine, Tower, TurboLink, EdgeScale, EdgeLock, eIQ, and Immersive3D are trademarks of NXP B.V. All other product or service names are the property of their respective owners. AMBA, Arm, Arm7, Arm7TDMI, Arm9, Arm11, Artisan, big.LITTLE, Cordio, CoreLink, CoreSight, Cortex, DesignStart, DynamIQ, Jazelle, Keil, Mali, Mbed, Mbed Enabled, NEON, POP, RealView, SecurCore, Socrates, Thumb, TrustZone, ULINK, ULINK2, ULINK-ME, ULINK-PLUS, ULINKpro, µVision, Versatile are trademarks or registered trademarks of Arm Limited (or its subsidiaries) in the US and/or elsewhere. The related technology may be protected by any or all of patents, copyrights, designs and trade secrets. All rights reserved. Oracle and Java are registered trademarks of Oracle and/or its affiliates. The Power Architecture and Power.org word marks and the Power and Power.org logos and related marks are trademarks and service marks licensed by Power.org. M, M Mobileye and other Mobileye trademarks or logos appearing herein are trademarks of Mobileye Vision Technologies Ltd. in the United States, the EU and/or other jurisdictions.