

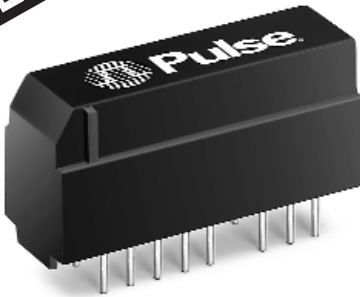



# ISDN S-INTERFACE MODULES

## Through-Hole, Dual, 1500 Vrms



**NEW!**



-  Meets the pulse waveform template of CCITT I.430 when recommended module and chip pair are used
-  UL1950 approved to basic isolation
-  Compatible with industry standard footprints
-  Developed for enhanced EMC performance

### Electrical Specifications @ 25°C — Operating Temperature 0°C to 70°C

Part Number	Transformer							Choke		$\Delta I_{bc}$ (mA Max)	Secondary Pins	Package / Schematic
	Ratio $\pm 2\%$ (Pri:Sec)	OCL Pri (mH Min)	LL Sec ( $\mu$ H MAX)	Cw/w (pF Max)	CD Pri (pF Max)	DCR Pri ( $\Omega + 25\%$ MAX)	DCR Sec ( $\Omega$ MAX)	OCL (mH Min)	DCR ( $\Omega$ )			
T5011	1CT:1CT	30	10	150	100	3.2	3.2 (+25%)	4.7	1.2	5	9-7,10-12	BER 1/B
T5012	1CT:2CT	30	30	150	100	3.2	5.4 (+25%)	4.7	1.2	5	9-7,10-12	BER 1/B
T5013	1CT:2.5CT	30	30	150	110	3.2	9.0	4.7	1.2	5	9-7,10-12	BER 1/B
T5015	1CT:2	30	30	150	100	3.2	5.4 (+25%)	4.7	1.2	5	9-10,8-11	BER 1/A*

\*Note: Pins 7 and 12 are not included with package.

### Mechanical

### Schematic

#### BER-1

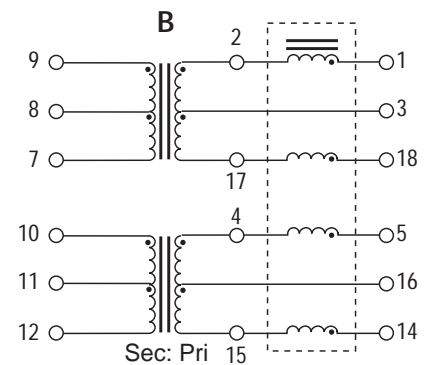
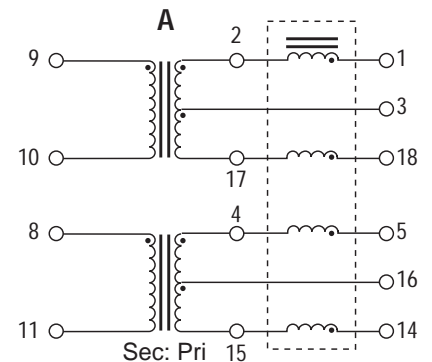
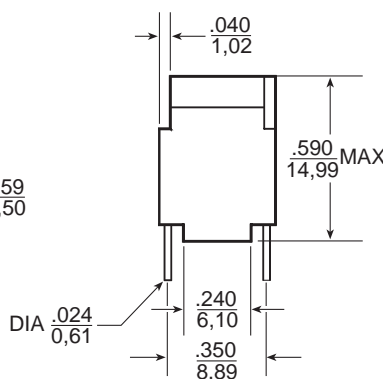
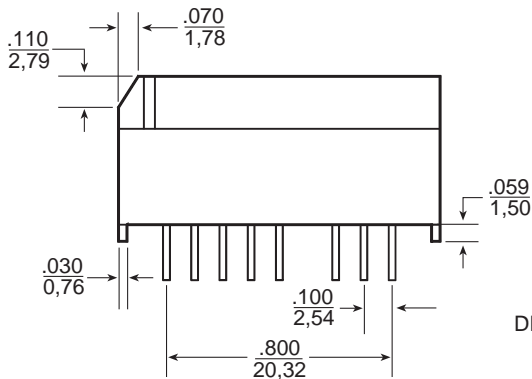
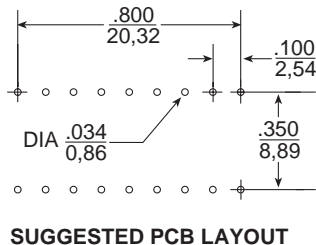
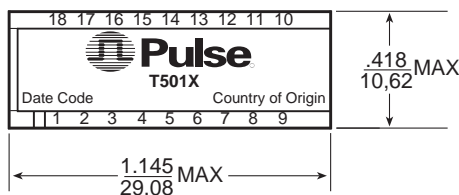

Dimensions:  $\frac{\text{Inches}}{\text{mm}}$

Unless otherwise specified all tolerances are  $\pm \frac{.010}{0.25}$

Weight ..... .8.0 grams  
 Tube ..... .20/tube

# ISDN S-INTERFACE MODULES

## Through-Hole, Dual, 1500 Vrms



### Module Selection Guide

IC Manufacturer	IC Part Number	Pulse Part Number
AMD Lucent (AT & T)	AM 79C 30A/79C	T5012/T5015
	T7234/ T7254 / T7250 / T7256 / T7259	T5013
	T7903	T5012 / T5015
Mietec	MTC-2072	T5012 / T5015
Mitel	MT8930 / 8931	T5012 / T5015
Motorola	MC145474 / 145475	T5011
	MC145574	T5013
National	TP3420 / 3421	T5012 / T5015
SGS Thomson	ST5420 / 5421	T5012 / T5015
Siemens	PEB2080 / 2081 / 2084/ 2085/ 2086	T5012 / T5015
	PSB 2186	
Yamaha	YM7405B	T5012 / T5015

## Definition of Terms

**Ratio:** This is the turns ratio, expressed as “Primary : Secondary”. The term “CT” designates a center tapped winding.

**OCL:** Open Circuit Inductance, measured 20 KHz, 100 mV.

**L<sub>L Sec</sub> :** Leakage Inductance measured across the secondary with the respective primary winding short circuited.

**C<sub>ww</sub>:** Winding capacitance, formed by the primary and secondary wire. These wires form the “Plates” of this capacitor. Measured at 100 KHz, 20 mV.

**CD Pri:** This is the distributed capacitance.

**DCR:** This is the resistance of the windings when measured in DC conditions.

**Δ I<sub>DC</sub>:** The maximum specified unbalanced DC current capability of the device.

The minimum primary inductance and the maximum distributed capacitance satisfy the transmitter output and receiver input impedance requirements of CCITT 1.430 for both TE & NT.

The maximum distributed capacitance allows sufficient margin for the capacitance of the IC and a protection diode network. It is consistent with the overall maximum value specified and permitted length of the basic access TE cord.

**Flammability** – Materials used in the products are recognized UL94-VO. Products meet the requirements of IEC 695-2-2 (needle flame test).

**Safety Standards** – All transformers listed in this data sheet are designed to meet UL1459 and UL1950 as a basic insulation barrier (UL file number E133523).

# ISDN S-INTERFACE MODULES

## Through-Hole, Dual, 1500 Vrms



### Common Mode Choke Performance

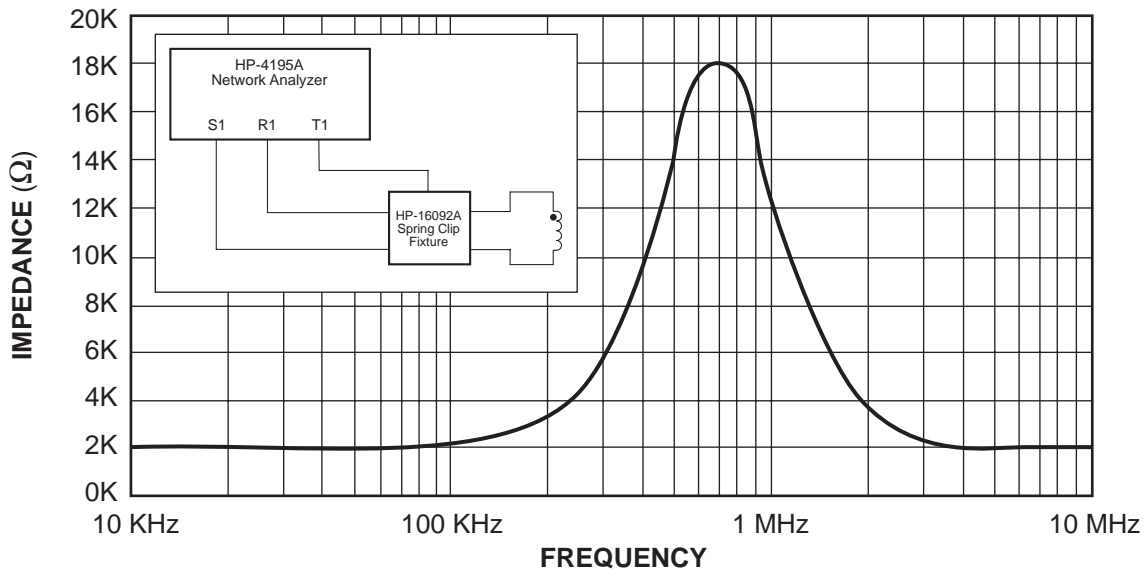
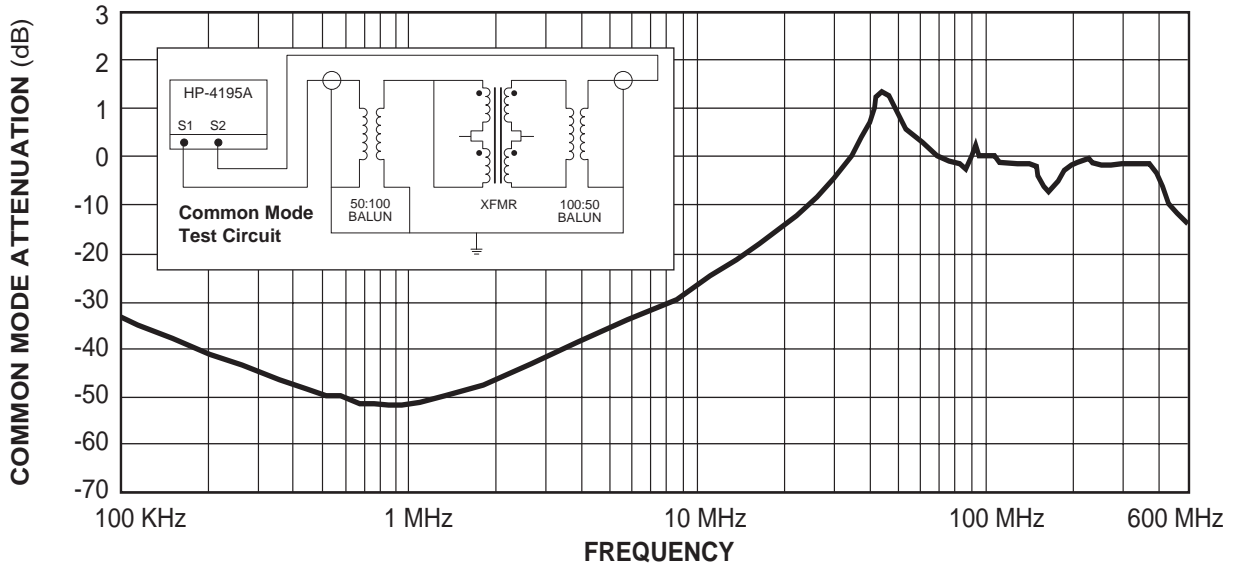

**Note:** The above data was obtained using a HP4195A Network/Spectrum Analyzer, across pins (1-2), (4-5), (14-15) or (17-18) using a fixture which is applicable to this instrument.