

CURRENT TRANSFORMERS

FOR ELECTRONIC WATTHOUR METERS

ADVANCED MATERIALS – THE KEY TO PROGRESS

VAC
VACUUMSCHMELZE

CURRENT TRANSFORMERS

FOR ELECTRONIC WATTHOUR METERS

VACUUMSCHMELZE GmbH & Co. KG (VAC) is one of the worldwide leading manufacturers of metallic materials and inductive components manufactured from these alloys. In the field of electromagnetic compatibility (EMC), VAC has been supplying high performance products for more than 20 years.

**MORE THAN
25 MILLION METERS
OPERATE WITH
VAC MATERIALS**

Electronic watthour meters have gradually been replacing the electromechanical Ferraris meters in industry for some years. Because of their many advantages such as extended scope of functions with system capabilities, insusceptibility to mechanical wear, small size and higher accuracy, they are also increasingly spread in private households all over the world. Their area of application covers a wide range from local individual devices through pre-payment meters right up to (supra)regional networked remote control and readout systems.

One of the key components in multi-phase and partly also in single-phase meters is the current transducer. This provides the electrical network isolation and supplies an accurate measuring variable (signal voltage) for the primary current. With respect to its measuring error, it must meet the requirements defined in the various technical standards for the respective device accuracy class. In Europe these are usually the standards IEC 62053 -21, -23 for directly connected meters and IEC 62053 -22 for indirectly connected meters; for the Anglo-American market the standards of the ANSI C12.xx series for both types of connections.

There is a number of functional principles for implementation of the current transducer. The shunt resistor is one of the favorite choices because of its very low cost and good linearity but designers have to beware of its disadvantages. Because of the regulations about maximum power consumption (max. 2 W per phase acc. to IEC 62053-21, -23) its resistance is limited to some hundreds of microhms. This low value results in very low voltages (typ. some ten microvolts) at low primary currents. These have to be very carefully filtered and amplified to keep the meter's specified accuracy in the low current region. Heat dissipation within the meter is another critical point to be considered. In cases of multi-phase meters or single-phase meters with external

interface additional galvanic separation has to be provided to prevent hazardous operation or short circuit conditions between the phases. Mostly optocouplers and separation transformers will be additionally needed increasing the meter's overall cost. Another favorite principle is the Rogowski coil which does not exhibit saturation effects due to its coreless operation. The disadvantage of this is common to all open magnetic circuits and results in a very interference sensitive operation. Costly shielding has to be provided to keep measurement errors small at low primary currents. The designs using semiconductor hall effect devices have to be clearly separated: the low cost types can suffer from ageing effects which can deteriorate accuracy in the course of years; stabilized designs will control these effects but at the cost of a complicated compensation circuitry.



In comparison to other principles toroidal core current transformers with low burden resistor have several obvious advantages:

- closed magnetic circuit:
 - less sensitive to interference fields
 - usually no shielding required
- magnetic function principle without semiconductors:
 - high long-term stability
 - no need for additional circuitry
- simple assembly with just a few parts:
 - low assembly expenses, compact designs
 - attractive prices

The properties of the toroidal core current transformers such as maximum transmissible primary current, amplitude and phase error as well as linearity are basically determined by the material used for the magnetic core. The three areas of application mentioned place different demands on the respective materials:

For meters according to IEC 62053-22 and ANSI C12.xx materials with high permeability in connection with the comparatively high flux density ranges of the metallic materials and only slight changes in properties as a function of the

temperature are of advantage. Current transformers with high-grade amorphous (VITROVAC®) or nanocrystalline (VITROPERM®) alloys from VAC offer extra advantages to the users:

- very small and high linear phase and amplitude error
- easily compensable phase error
- low temperature dependence

Meters according to IEC 62053 -21, -23 must have a tolerance to DC current components (“direct current tolerance”) which can saturate conventional current transformers when unipolar alternating currents occur, e.g. from power supply units with primary side diodes. Classical high permeability cores will saturate and are not suitable for above mentioned standard. Other solutions with a combination of two different alloys or iron based cores suffer from lack of linearity. Magnetic cores made of very linear but still highly excitable amorphous alloys from VAC are used for this. These lend the current transformer excellent properties:

- standard compliant DC tolerance without air gap
- negligible small amplitude error
- extreme linear, easily compensable phase curve
- extreme low temperature dependence

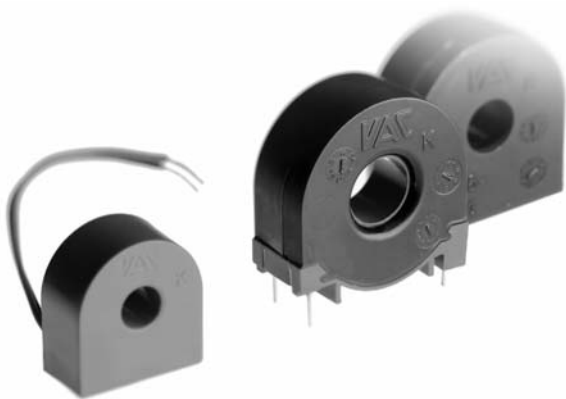

PRINCIPLES OF CIRCUITRY

The primary current dependent errors of amplitude and phase are decisive for the energy measurement error when using current transformers. With meters of medium accuracy without direct current tolerance both have very low absolute values and can therefore be well compensated by a meter type-related correction in the circuit.

The current transformers with direct current tolerance have the special feature of a relatively high absolute phase error value at high constancy whereas the amplitude error is negligibly small. This causes an energy measurement error which varies only slightly with the primary current and which adopts impermissibly high values on complex loads (e.g. inductive load with $\cos \varphi = 0.5$) if the phase error is not carefully compensated.

Since the specified scatter of the secondary inductance L cannot be reduced at will, the phase error of the individual converters is scattered batch-dependently to the same extent. An individual correction is therefore recommended to stay reliably within the error limits. This can be performed with a suitable digital signal processor (DSP) which is digitally adjusted to the implemented current transformer in a calibration run at a single current value (e.g. at I_b). Particularly high accuracy can be achieved when the phase error curve is measured at several currents and is approximated between these for correction.

This is often impossible or only to a certain extent in devices with DSPs of a simple internal structure. Here correction is possible by an RC low-pass connected in series with the analog current measuring input, whereby a C-value of typ. 150 to 300 nF is suitable for an R of approx. 1 k Ω . Because of the scatter of the L-values an adapted use of grouped C-values may be necessary.

If further modifications of the operating parameters are necessary, we offer the recalculation of the error characteristics on request.

BLOCK DIAGRAM OF AN ELECTRONIC WATTHOUR METER

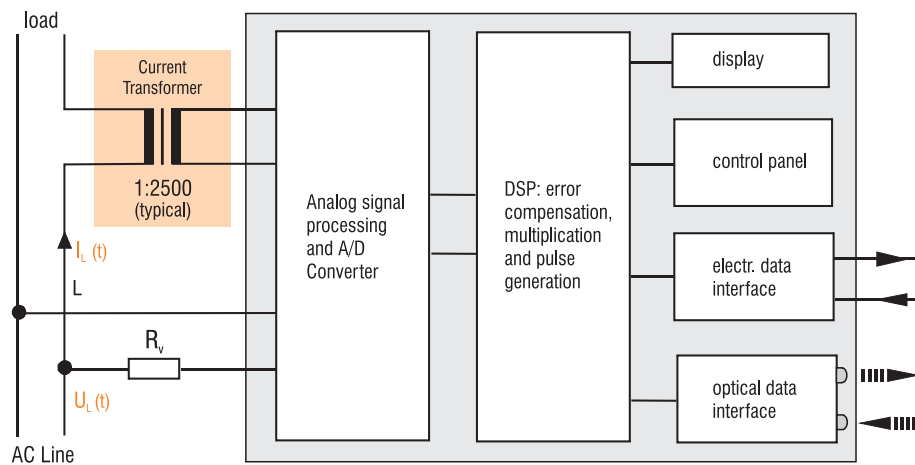

CURRENT TRANSFORMER STANDARD TYPES FOR ELECTRONIC WATTHOUR METERS

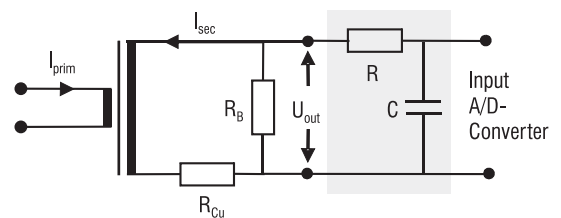

TABLE 1: CURRENT TRANSFORMERS FOR DIRECT CONNECTION WITH DC-TOLERANCE ACCORDING TO IEC 62053 -21, -23 (operating frequency 50 Hz)

Order Code T60404-...	Primary Current Range		Ratio 1 : []	Phase Error $\varphi(l)$ [°]	Characteristical Values				Dimensions			
	I_{max}	\hat{I}_{peak}			L [H]	R_{DC} [Ω]	R_B [Ω]	U_B [V _{rms}]	Inner dia. ∅ [mm]	Width D [mm]	Height H [mm]	Pin/ Wire
	[A _{rms}]	[A _{Op}]										
...E4622-X101	20	20	2500	3.69	4.6	54	37.5	0.3	5.0	28.5	14.5	Wire
...E4623-X101	40	40	2500	4.28	3.7	66	18.8	0.3	5.5	28.0	16.0	Wire
...E4624-X101	60	60	2500	4.42	3.0	55	12.5	0.3	8.0	30.5	15.0	Wire
...E4624-X501	60	60	2500	4.42	3.0	55	12.5	0.3	8.5	31.0	14.0	Pin
...E4625-X101	80	80	2500	5.20	2.4	54	9.4	0.3	8.0	30.5	15.0	Wire
...E4625-X501	80	80	2500	5.20	2.4	54	9.4	0.3	8.5	31.0	14.0	Pin
...E4626-X101	100	100	2500	4.73	2.1	44	7.5	0.3	9.5	35.0	15.0	Wire
...E4626-X501	100	100	2500	4.73	2.1	44	7.5	0.3	11.5	34.0	14.0	Pin
...E4627-X101	120	120	2500	4.35	1.8	34	6.25	0.3	12.0	39.0	18.0	Wire

APPLICATION NOTES

The excellent soft magnetic properties of the VAC core material for DC-tolerant CTs leads to a negligible small amplitude error as well as to an extremely low and linear temperature dependence. Due to the low permeability, a phase error of typically 4° to 5° occurs which is easy to compensate on account of its high constancy of typically ± 0.05°. The compensation can be made digitally by appropriate correction in the microprocessor and analogously by an RC low-pass in front of the input of the A/D converter. A number of major metering chip providers supply tailored solutions for optimum performance and accuracy in combination with these CT types.



$$C = (R_{Cu} + R_B) / \omega^2 \cdot R \cdot L$$

Condition for value of R:

$R_B \ll R \ll |Z|$ of converter;

typical value $R = 1 \text{ k}\Omega$

Typ. C values: 150 . . . 300 nF

**TABLE 2: CURRENT TRANSFORMERS FOR DIRECT CONNECTION WITHOUT DC-TOLERANCE
(operating frequency 50 Hz)**

Order Code T60404-...	Primary Current Range		Ratio 1 : []	Phase Error $\varphi(l)$ [°]	Characteristic Values				Dimensions			
	I_{max}	\hat{I}_{peak}			L [H]	R_{DC} [Ω]	R_B [Ω]	U_B [V _{rms}]	Inner dia. ∅ [mm]	Width D [mm]	Height H [mm]	Pin/ Wire
	[A _{rms}]	[A _{Op}]										
...E4622-X002	20	-	2500	0.18	113	54	37.5	0.3	5.0	28.5	14.5	Wire
...E4623-X002	40	-	2500	0.12	155	61	18.8	0.3	5.5	28.0	16.0	Wire
...E4624-X002	60	-	2500	0.13	122	55	12.5	0.3	8.0	30.5	15.0	Wire
...E4624-X502	60	-	2500	0.13	122	55	12.5	0.3	8.5	31.0	14.0	Pin
...E4626-X002	100	-	2500	0.11	97	44	7.5	0.3	9.5	35.0	15.0	Wire
...E4626-X502	100	-	2500	0.11	97	44	7.5	0.3	11.5	34.0	14.0	Pin

**TABLE 3: CURRENT TRANSFORMERS FOR INDIRECT CONNECTION WITHOUT DC-TOLERANCE
ACCORDING TO IEC 62053 -22 (operating frequency 50 Hz)**

Order Code T60404-...	Primary Current Range		Ratio 1 : []	Phase Error $\varphi(l)$ [°]	Characteristic Values				Dimensions			
	I_{max}	\hat{I}_{peak}			L [H]	R_{DC} [Ω]	R_B [Ω]	U_B [V _{rms}]	Inner dia. ∅ [mm]	Width D [mm]	Height H [mm]	Pin/ Wire
	[A _{rms}]	[A _{Op}]										
...E4629-X007	6	-	2000	0.37	110	115	100	0.3	7.0	23.0	11.0	Wire
...E4622-X501	6	-	2000	0.37	110	115	100	0.3	6.3	24.5	11.5	Pin
...E4629-X010	6	-	2000	0.17	238	114	100	0.3	7.0	23.0	11.0	Wire
...E4622-X503	6	-	2000	0.17	238	114	100	0.3	6.3	24.5	11.5	Pin
...E4658-X043	6	-	1500	0.46	35	46	75	0.3	5.0	16.8	9.0	Pin

**TABLE 4: CURRENT TRANSFORMERS FOR DIRECT / INDIRECT CONNECTION WITHOUT DC-TOLERANCE
ACCORDING TO ANSI C12.xx (operating frequency 60 Hz)**

Order Code T60404-...	Primary Current Range		Ratio 1 : []	Phase Error $\varphi(l)$ [°]	Characteristic Values				Dimensions			
	I_{max}	\hat{I}_{peak}			L [H]	R_{DC} [Ω]	R_B [Ω]	U_B [V _{rms}]	Inner dia. ∅ [mm]	Width D [mm]	Height H [mm]	Pin/ Wire
	[A _{rms}]	[A _{Op}]										
...E4629-X007	20	-	2000	0.19	110	115	30	0.3	7.0	23.0	11.0	Wire
...E4622-X501	20	-	2000	0.19	110	115	30	0.3	6.3	24.5	11.5	Pin
...E4629-X010	20	-	2000	0.10	238	114	30	0.3	7.0	23.0	11.0	Wire
...E4622-X503	20	-	2000	0.10	238	114	30	0.3	6.3	24.5	11.5	Pin
...E4627-X001	200	-	1000	0.11	25	16	1.5	0.3	8.5	30.0	17.5	Wire
...E4628-X001	320	-	1000	0.10	20	10	0.94	0.3	11.0	35.0	18.5	Wire

EXPLANATION OF TABLES 1 TO 4:

Noted values are typical at room temperature (25 °C). All types are designed as bar- type CTs with one primary turn ($N_1 = 1$).

I_{\max} = maximum AC primary current with defined errors

\hat{I}_{peak} = max. half wave rectified AC amplitude without saturation (for Class 1 meter (IEC 62053 -21, -23): $F(\hat{I}_{\max}) < 3\%$)

$\varphi(I)$ = max. phase error for $I < I_{\max}$

$F(I)$ = max. amplitude error for $I < I_{\max}$

N_2 = no. of secondary turns

L = inductance at moderate excitation level ($I < I_{\max}$)

R_{DC} = winding resistance

R_B = burden resistor

U_B = output voltage across burden resistor R_B at I_{\max}

\varnothing = diameter of centre hole

D = maximum width of component in mm

h = maximum thickness of component in mm

For further details please see datasheets, which are provided on www.vacuumschmelze.com

EXAMPLES FOR CUSTOMIZED CURRENT TRANSFORMER DESIGNS

In addition to the illustrated standard types, customized developments (see below) are also possible when sufficiently large quantities are needed. Please fill in the enclosed checklist as completely as possible and send it back to us if required.

If the principle-related sensitivity to external errors in special applications is still too high, we recommend a plate (iron, thickness approx. 1 to 2 mm) mounted as an additional magnetic shield between the meter housing and the current transformer. The edges should be as far away as possible from the transformer; a value between half and the full distance between the transformer and the housing is recommended as the optimum choice.

Especially for antitampering purposes we provide a solution like seen on right picture. The wound core is encapsulated with a deep-drawing pair of caps.

Dielectric strength test:

For standard type housings the following values are valid for the insulation between a bare copper primary conductor and the secondary winding (different test values on request):

$U_{p \text{ rms}}$ = 2.5 kV (50 / 60 Hz, 1 min) and

$U_{p \text{ max}}$ = 6 kV (1.2 μ s / 50 μ s – test pulse)

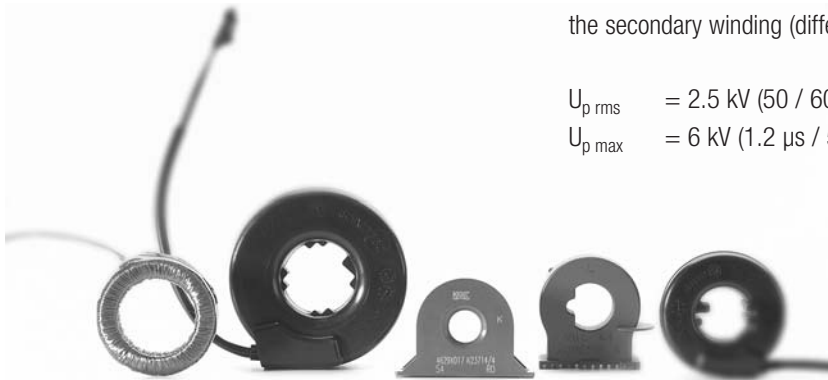

TYPICAL TEMPERATURE DEPENDENCE OF PHASE ANGLE AND AMPLITUDE ERRORS

20 A with DC-Tolerance, T60404-E4622-X101

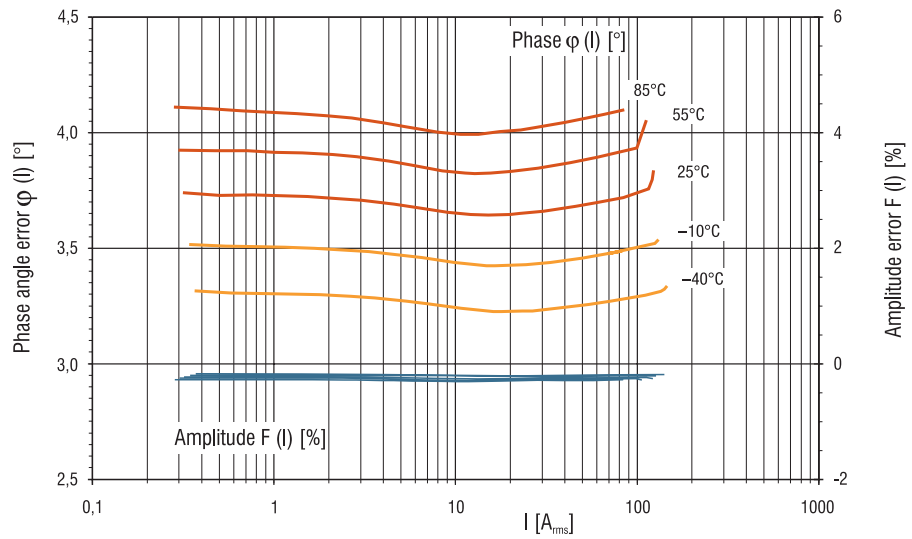

40 A with DC-Tolerance, T60404-E4623-X101

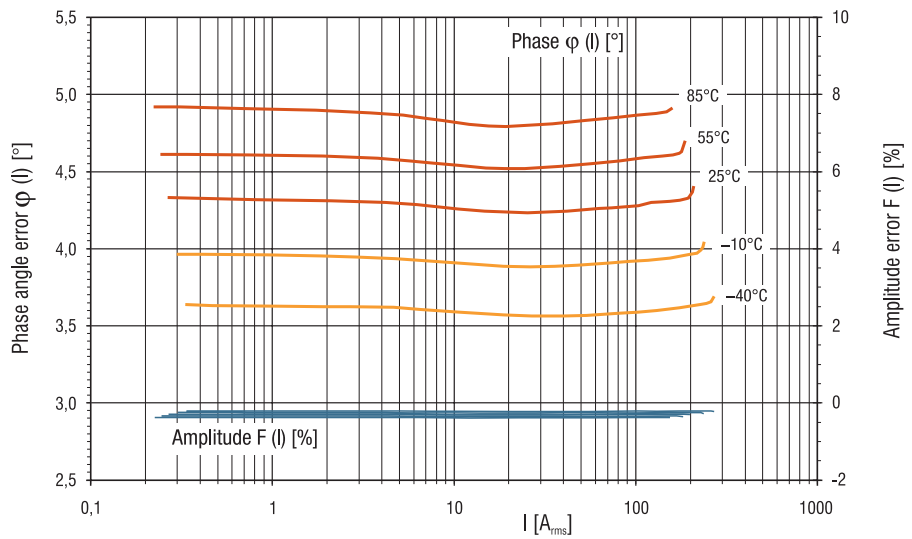

TYPICAL TEMPERATURE DEPENDENCE OF PHASE ANGLE AND AMPLITUDE ERRORS

60 A with DC-Tolerance, T60404-E4624-X101/-X501

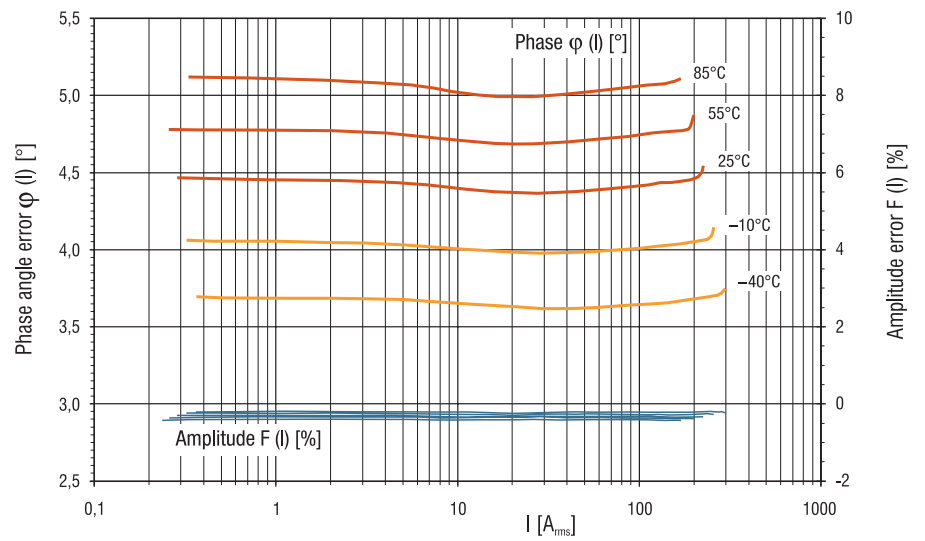

80 A with DC-Tolerance, T60404-E4625-X101/-X501

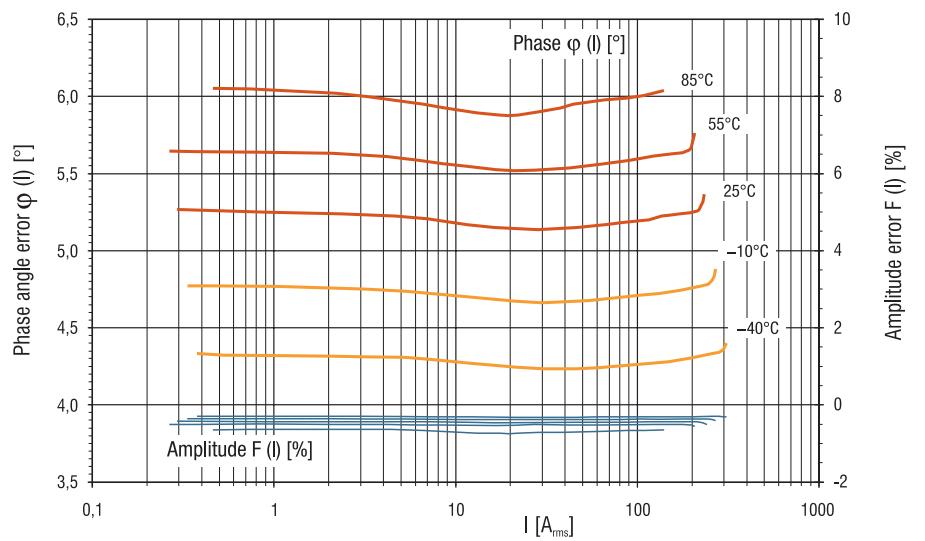

100 A with DC-Tolerance, T60404-E4626-X101/-X501

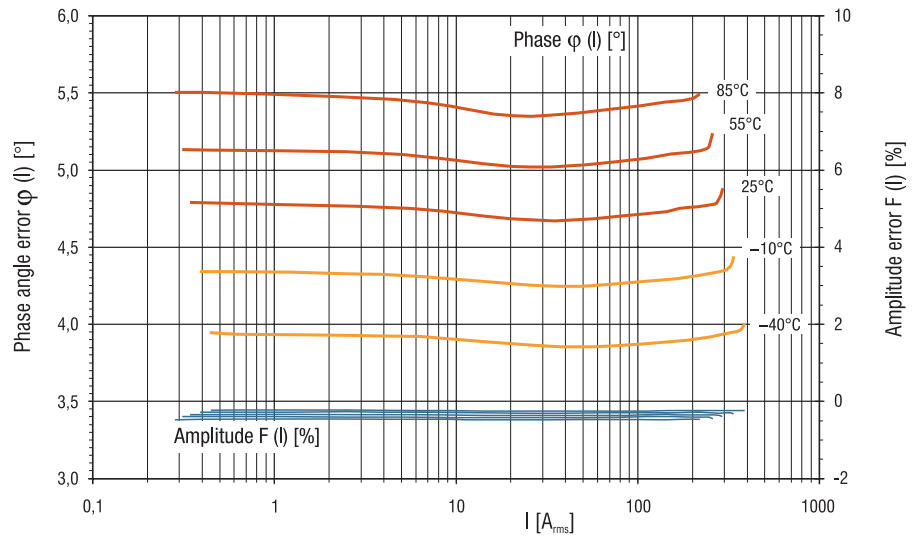

120 A with DC-Tolerance, T60404-E4627-X101

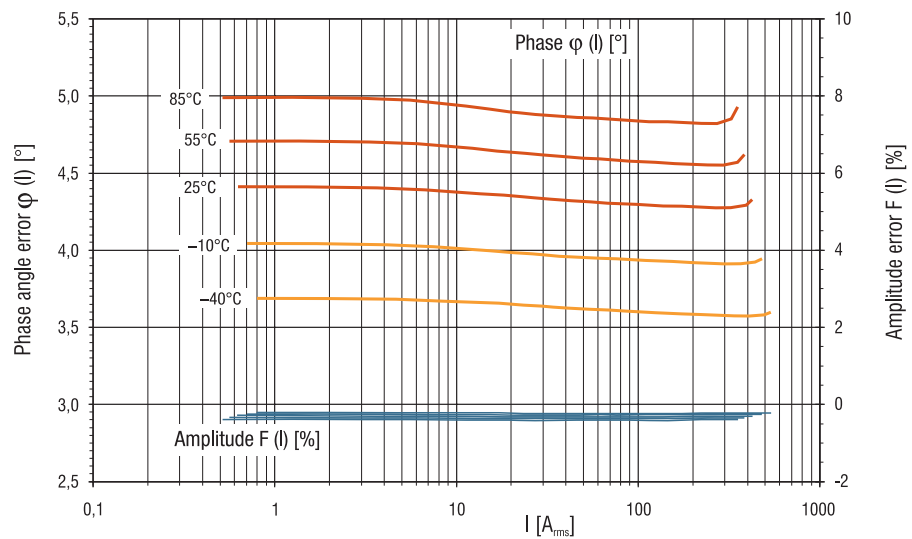

TYPICAL TEMPERATURE DEPENDENCE OF PHASE ANGLE AND AMPLITUDE ERRORS

20 A, T60404-E4622-X002

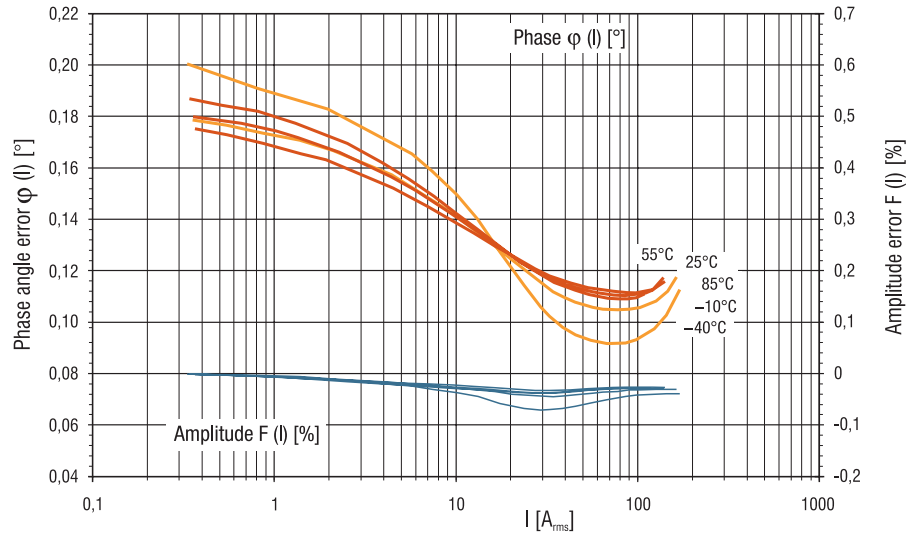

40 A, T60404-E4623-X002

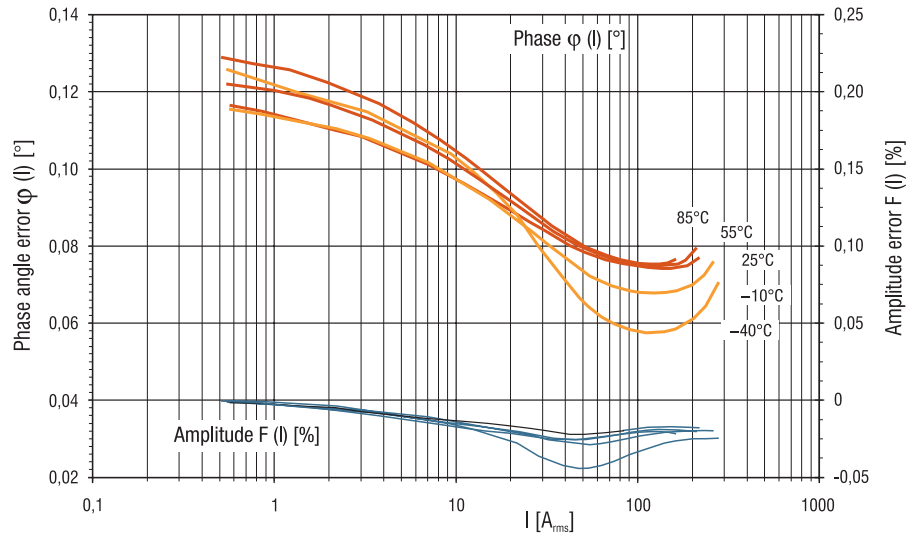

60 A, T60404-E4624-X002/-X502

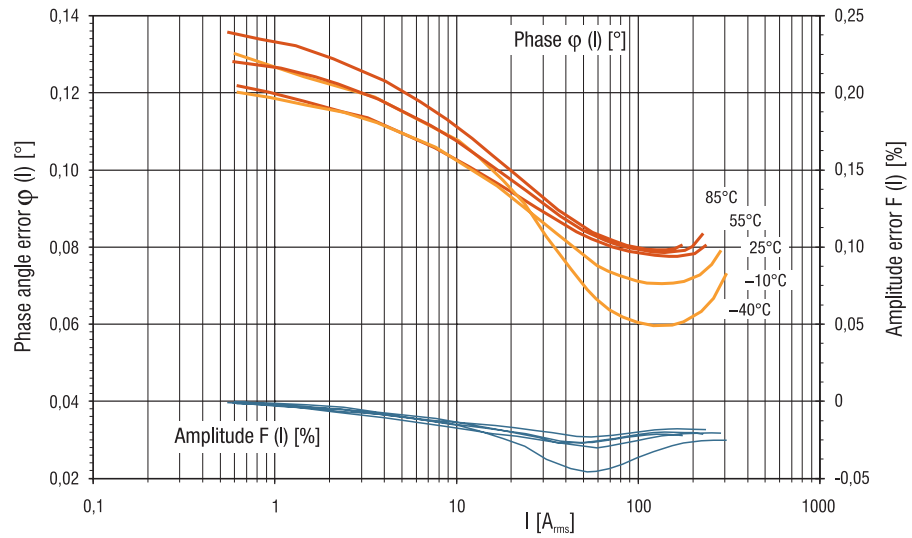

100 A, T60404-E4626-X002/-X502

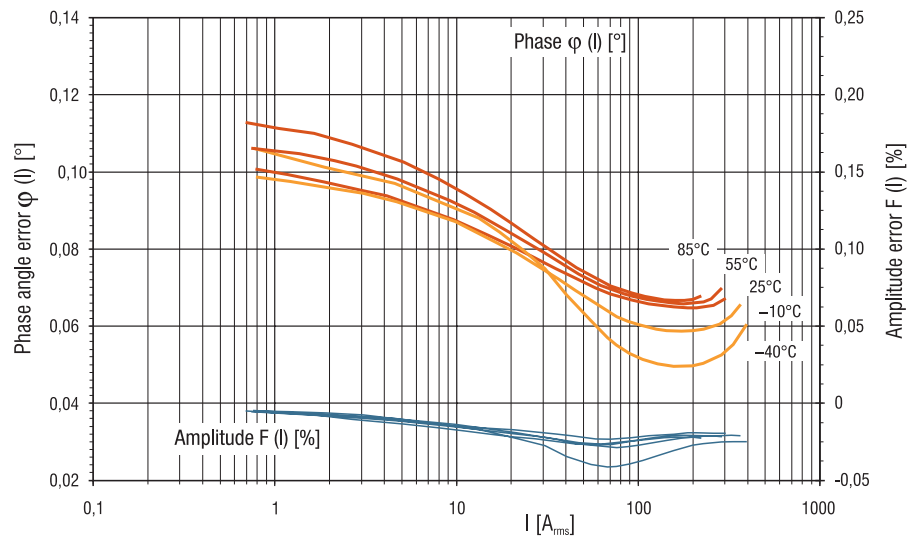

TYPICAL TEMPERATURE DEPENDENCE OF PHASE ANGLE AND AMPLITUDE ERRORS

6 A, T60404-E4629-X007/E4622-X501

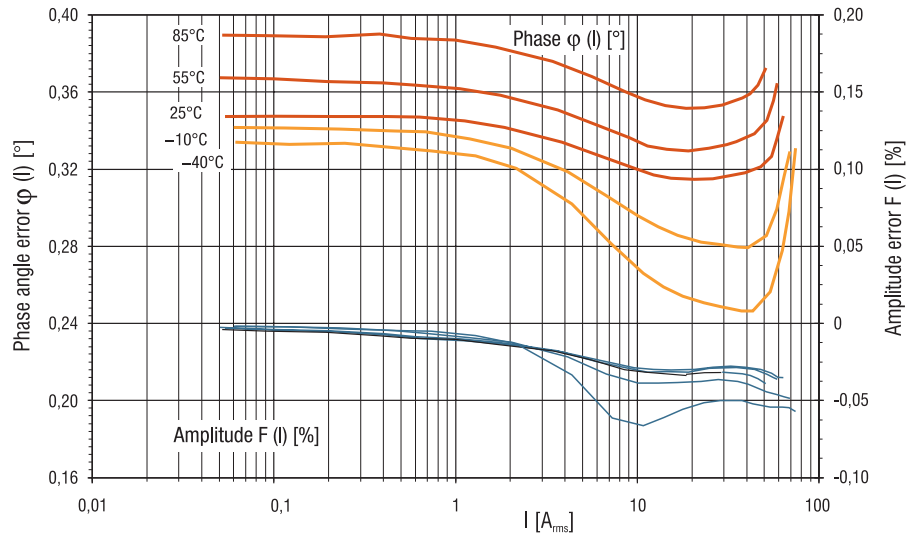

6 A, T60404-E4629-X010/E4622-X503

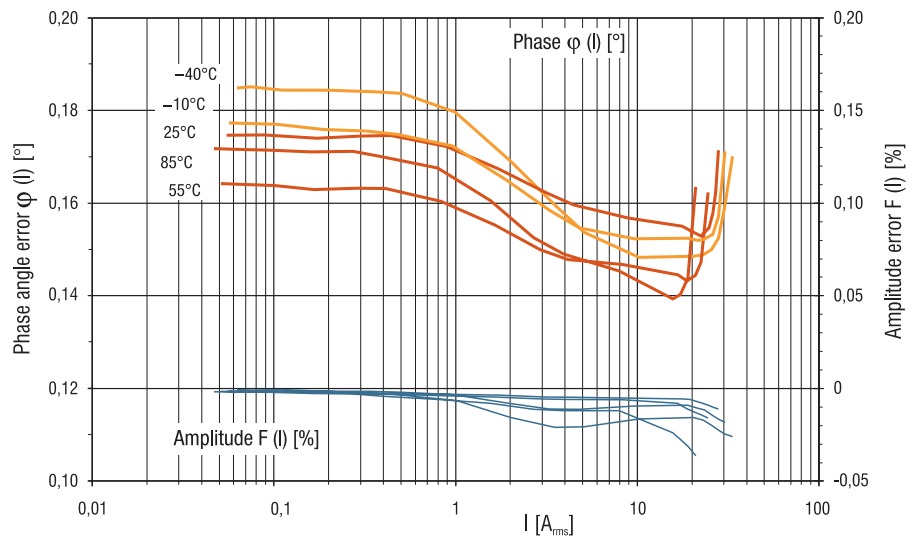

6 A, T60404-E4658-X043

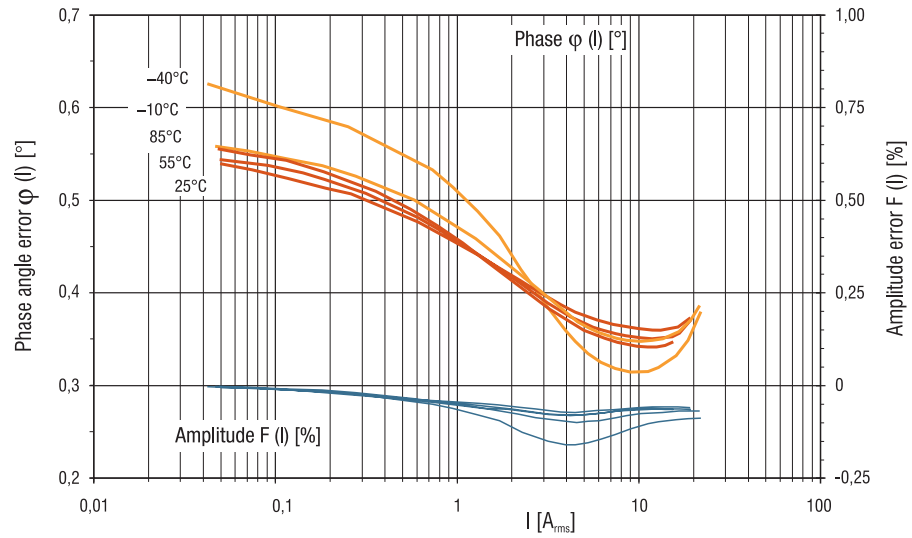

20 A, T60404-E4629-X007/E4622-X501

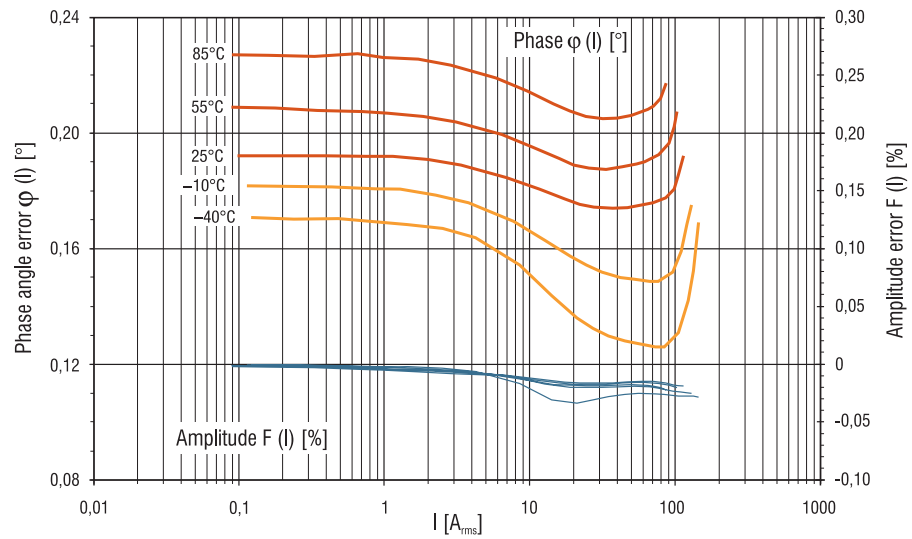

TYPICAL TEMPERATURE DEPENDENCE OF PHASE ANGLE AND AMPLITUDE ERRORS

20 A, T60404-E4629-X010/E4622-X503

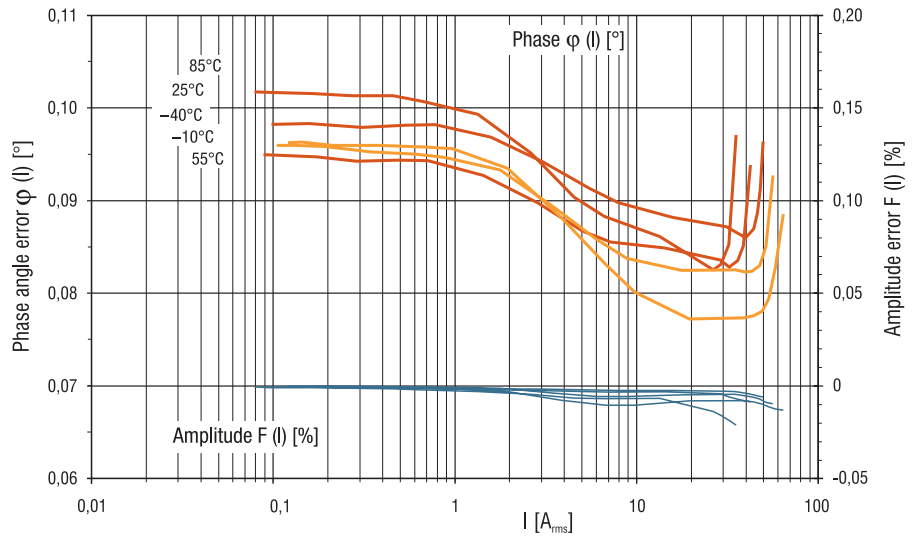

200 A, T60404-E4627-X001

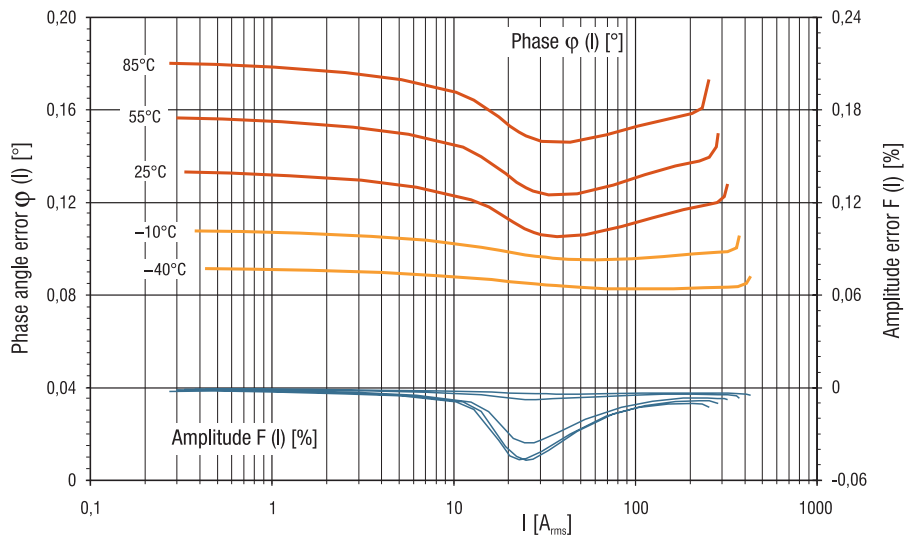

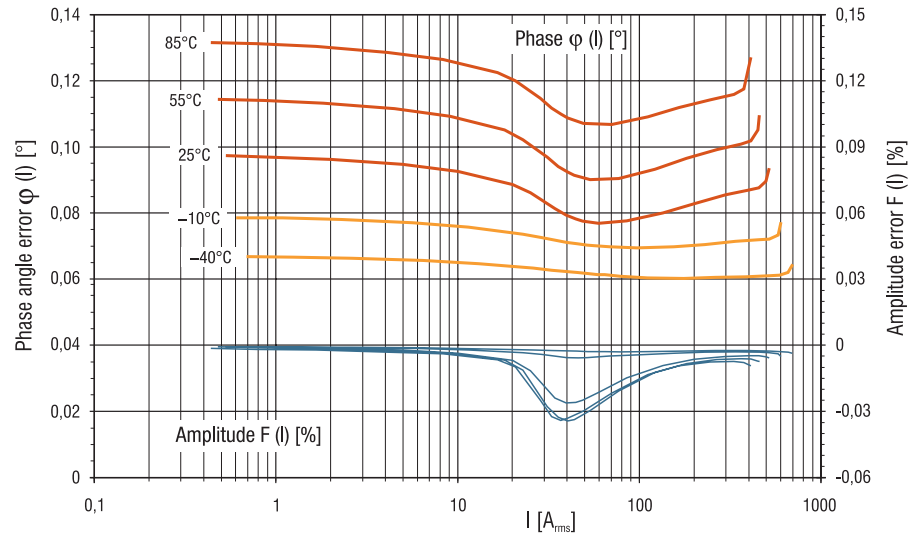

TYPICAL BEHAVIOUR OF DIFFERENT VAC CORE MATERIALS

Classical crystalline 80 % NiFe vs. rapid solidified VAC alloys

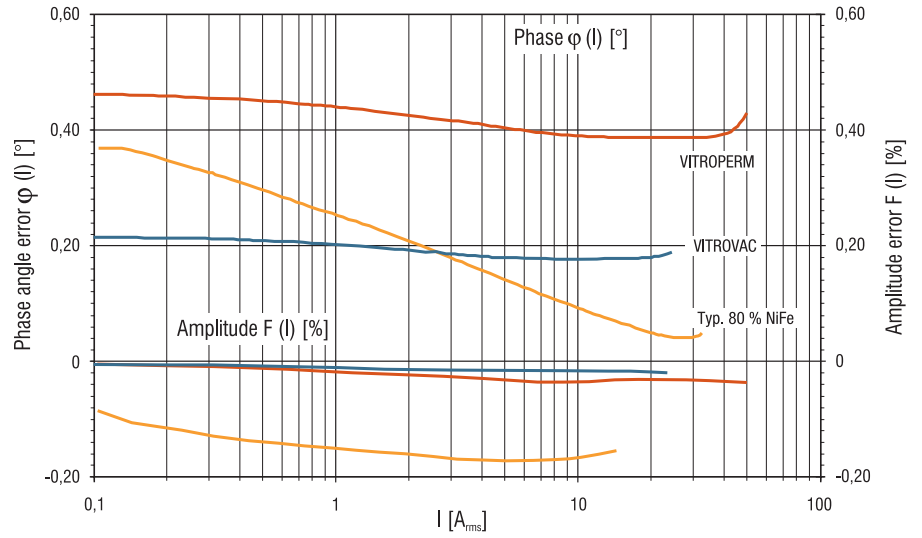

TYPICAL CHARACTERISTIC OF AMPLITUDE ERROR VS. PRIMARY CURRENT

100 A, T60404-E4626-X101/-X501

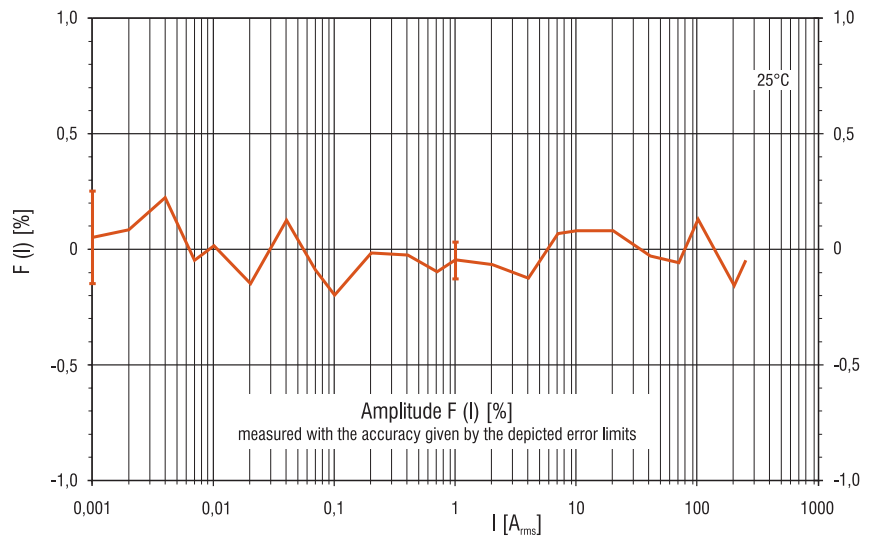

TYPICAL CHARACTERISTIC OF AMPLITUDE ERROR VS. UNIPOLAR (HALF – WAVE RECTIFIED) PRIMARY CURRENT

100 A, T60404-E4626-X101/-X501

