

**NOTICE OF PROPRIETARY RIGHTS** THIS DOCUMENT CONTAINS CONFIDENTIAL TECHNICAL DATA, INCLUDING TRADE SECRETS, PROPRIETARY TO TIMES MICROWAVE SYSTEMS. DISCLOSURE OF THIS DATA IS EXPRESSLY CONDITIONED UPON YOUR ASSENT THAT ITS USE IS LIMITED TO USE WITHIN YOUR COMPANY ONLY. ANY OTHER USE IS STRICTLY PROHIBITED WITHOUT THE PRIOR WRITTEN CONSENT OF TIMES MICROWAVE SYSTEMS.

SYM	REVISION DESCRIPTION	DFTM	DATE	APPD	DATE
A	RELEASED FOR PRODUCTION	N. N. N	1/13/14	J. D. B.	1/13/14
B	CHANGED PER CDC #39339	N. N. N	2/20/14	J. D. B.	2/20/14

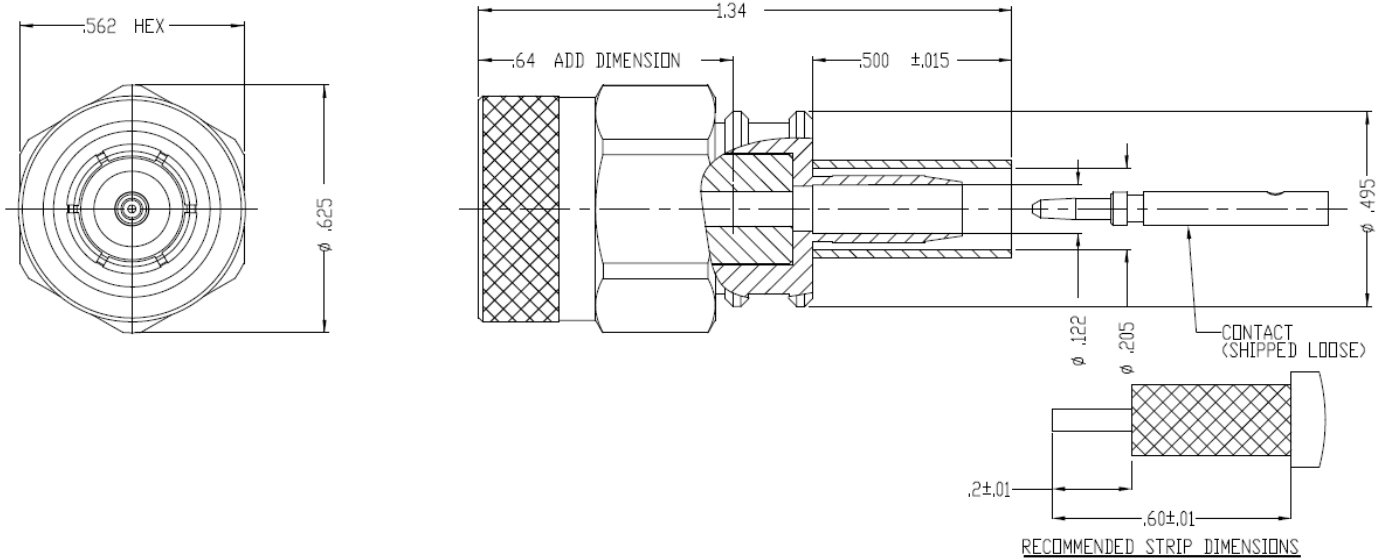

**NOTES:**

- ASSEMBLED CONNECTOR INTERFACE IS IN ACCORDANCE WITH MIL-STD-438.
- MATERIAL:**  
 BODY, CONTACT, COUPLING SLEEVE - BRASS PER ASTM B16, C36000 ALLOY, TEMPER H02  
 INSULATOR - TEFLON PER ASTM D1710, TYPE 1, GRADE 1, CLASS A  
 SHRINK SLEEVE - HEAT SHRINKABLE ATUM PER MIL-I-23053/4 (NOT SHOWN)  
 CRIMP SLEEVE - D.H.P. COPPER CDA, ALLOY #122, TEMPER HARD  
 FINGERS - BERYLLIUM COPPER PER ASTM B196, C17300 ALLOY, CONDITION HT
- FINISH:**  
 CONTACT - GOLD PLATE PER ASTM B488  
 ALL OTHER METAL PARTS - SILVER PLATE PER ASTM B700

MATERIAL:	UNLESS OTHERWISE SPECIFIED		DFTM. N. N. N	TIMES MICROWAVE SYSTEMS	
	ALL DIMENSIONS ARE IN INCHES MACHINED SURFACES FINISH 63 RMS MAX. REMOVE ALL BURRS .004 MAX. BREAK MACHINE CORNERS .005 MAX. FILLET R. TOLERANCES ON DECIMALS . XX $\pm .01$ . XXX $\pm .005$ ANGLES $\pm 1^\circ$ FRACTIONS $\pm 1/64$		DATE 1/13/14		
USED ON: A			CHKD. J. D. B.	TC-195-TM-X CONNECTOR ASSEMBLY TNCM for LMR-195	
			DATE 1/13/14		
SCALE: NONE	DWG. SIZE A	DO NOT SCALE DRAWING	CODE IDENT 68999	APPD. J. D. B.	DATE 1/13/14
				SH	1 of 1
				REV	SD3190-2879
					B