

4 x 42 W quad bridge car radio amplifier

Datasheet – production data

Features

- High output power capability:
 - 4 x 42 W / 4 Ω max.
 - 4 x 23 W / 4 Ω @ 14.4 V, 1 kHz, 10 %
- Clipping detector
- Low distortion
- Low output noise
- Standby function
- Mute function
- Automute at min. supply voltage detection
- Diagnostics facility for:
 - Clipping
 - Out to GND short
 - Out to V_S short
 - Thermal shutdown
- Low external component count:
 - Internally fixed gain (26 dB)
 - No external compensation
 - No bootstrap capacitors
- Protections:
 - Output short circuit to GND, to V_S , across the load
 - Very inductive loads
 - Overrating chip temperature with soft thermal limiter
 - Load dump voltage
 - Fortuitous open GND

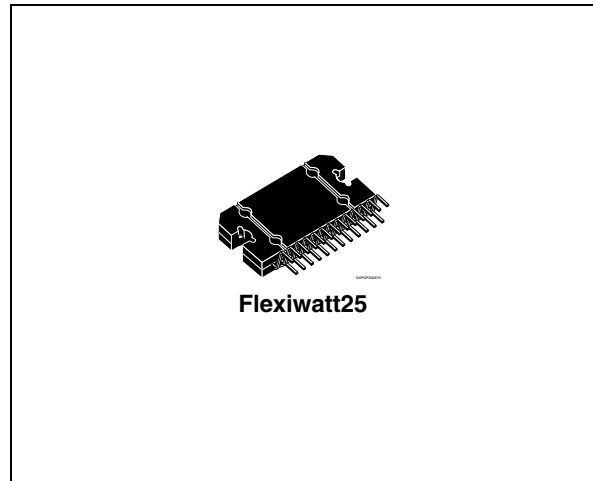

- Reversed battery
- ESD

Description

The TDA7385 is an AB class audio power amplifier, packaged in Flexiwatt 25 and designed for high end car radio applications.

Based on a fully complementary PNP/NPN configuration, the TDA7385 allows a rail to rail output voltage swing with no need of bootstrap capacitors. The extremely reduced boundary components count allows very compact sets.

The on-board clipping detector simplifies gain compression operations. The fault diagnostics makes it possible to detect mistakes during car-radio assembly and wiring in the car.

Table 1. Device summary

Order code	Package	Packing
TDA7385	Flexiwatt25	Tube
E-TDA7385 ⁽¹⁾	Flexiwatt25	Tube

1. Device in ECOPACK® package (see [Section 4: Package information on page 15](#)).

Contents

- 1 Block and pin connection diagrams 5**

- 2 Electrical specifications 6**
 - 2.1 Absolute maximum ratings 6
 - 2.2 Thermal data 6
 - 2.3 Electrical characteristics 6
 - 2.4 PCB and component layout 8
 - 2.5 Electrical characteristic curves 9

- 3 Application hints 11**
 - 3.1 Biasing and SVR 11
 - 3.2 Input stage 11
 - 3.3 Standby and muting 12
 - 3.4 Diagnostics facility 12
 - 3.5 Stability and layout considerations 13

- 4 Package information 15**

- 5 Revision history 16**

List of tables

Table 1.	Device summary	1
Table 2.	Absolute maximum ratings	6
Table 3.	Thermal data	6
Table 4.	Electrical characteristics	6
Table 5.	Document revision history	16

List of figures

Figure 1.	Block diagram	5
Figure 2.	Pin connection (top view)	5
Figure 3.	Standard test and application circuit	7
Figure 4.	Components and top copper layer	8
Figure 5.	Bottom copper layer	8
Figure 6.	Quiescent current vs. supply voltage	9
Figure 7.	Quiescent output voltage vs. supply voltage	9
Figure 8.	Output power vs. supply voltage (4Ω)	9
Figure 9.	Distortion vs. output power	9
Figure 10.	Distortion vs. frequency	9
Figure 11.	Supply voltage rejection vs. frequency by varying C6	9
Figure 12.	Output noise vs. source resistance	10
Figure 13.	Power dissipation and efficiency vs. output power	10
Figure 14.	Input/output biasing	11
Figure 15.	Diagnostics circuit	12
Figure 16.	Clipping detection waveforms	13
Figure 17.	Diagnostics waveforms	14
Figure 18.	Fault detection circuit	14
Figure 19.	Flexiwatt25 mechanical data and package dimensions	15

1 Block and pin connection diagrams

Figure 1. Block diagram

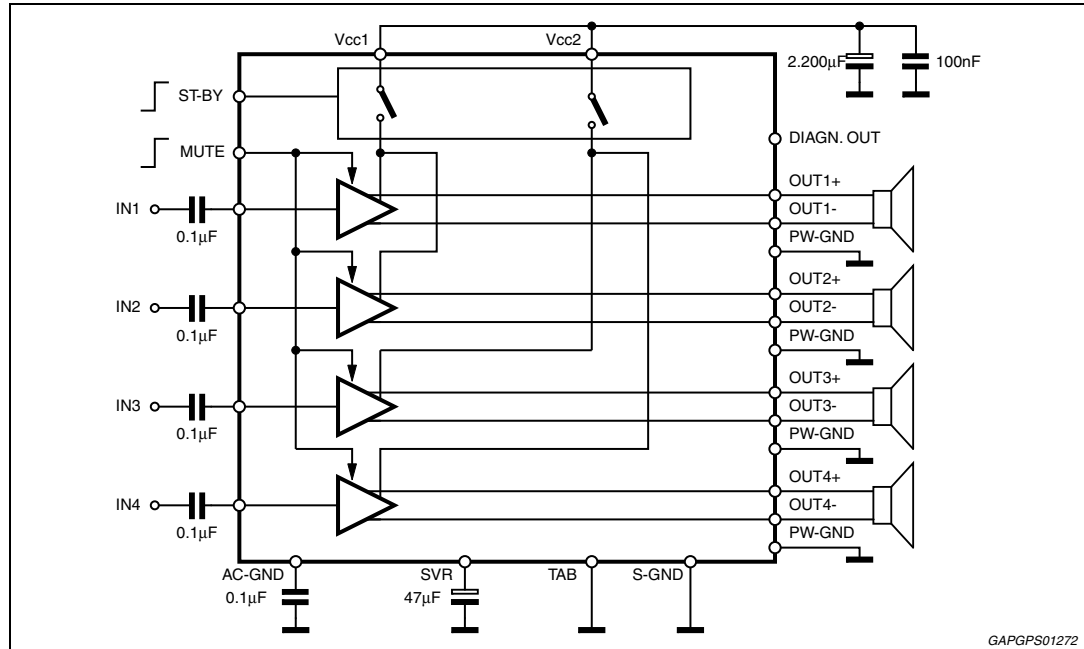

GAPGPS01272

Figure 2. Pin connection (top view)

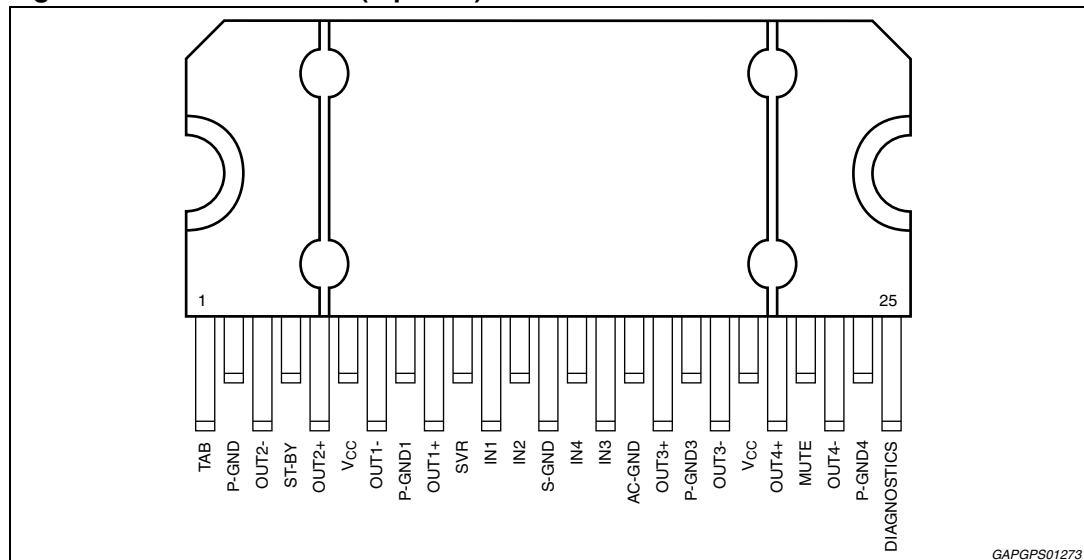

GAPGPS01273

2 Electrical specifications

2.1 Absolute maximum ratings

Table 2. Absolute maximum ratings

Symbol	Parameter	Value	Unit
V_S	Operating supply voltage	18	V
$V_{S(DC)}$	DC supply voltage	28	V
$V_{S(pk)}$	Peak supply voltage (t = 50 ms)	50	V
I_O	Output peak current: Repetitive (duty cycle 10 % at f = 10 Hz)	4.5	A
	Non repetitive (t = 100 μ s)	5.5	A
P_{tot}	Power dissipation, ($T_{case} = 70\text{ }^\circ\text{C}$)	80	W
T_j	Junction temperature	150	$^\circ\text{C}$
T_{stg}	Storage temperature	- 55 to 150	$^\circ\text{C}$

2.2 Thermal data

Table 3. Thermal data

Symbol	Parameter	Value	Unit
$R_{th\ j-case}$	Thermal resistance junction-to-case max.	1	$^\circ\text{C/W}$

2.3 Electrical characteristics

$V_S = 14.4\text{ V}$; f = 1 kHz; $R_g = 600\ \Omega$; $R_L = 4\ \Omega$; $T_{amb} = 25\text{ }^\circ\text{C}$; Refer to the test and application diagram ([Figure 3](#)), unless otherwise specified.

Table 4. Electrical characteristics

Symbol	Parameter	Test condition	Min.	Typ.	Max.	Unit
I_{q1}	Quiescent current	-	-	180	300	mA
V_{OS}	Output offset voltage	-	-	-	100	mV
G_v	Voltage gain	-	25	26	27	dB
P_o	Output power	THD = 10%	21	23	-	W
		THD = 1%	16.5	19	-	
		THD = 10%; $V_S = 13.2\text{ V}$	17	20	-	
		THD = 1%; $V_S = 13.2\text{ V}$	14	16	-	
$P_{o\ max.}$	Max. output power ⁽¹⁾	$V_S = 14.4\text{ V}$	33	35	-	W
		$V_S = 15.2\text{ V}$	-	42	-	W
THD	Distortion	$P_o = 4\text{ W}$	-	0.04	0.3	%

Table 4. Electrical characteristics (continued)

Symbol	Parameter	Test condition	Min.	Typ.	Max.	Unit
e_{No}	Output noise	"A" Weighted Bw = 20 Hz to 20 kHz	-	50 65	- 150	μ V μ V
SVR	Supply voltage rejection	f = 100 Hz	50	65	-	dB
f_{cl}	Low cut-off frequency	-	-	20	-	Hz
f_{ch}	High cut-off frequency	-	75	-	-	kHz
R_i	Input impedance	-	70	100	-	k Ω
C_T	Cross talk	f = 1 kHz	50	70	-	dB
I_{SB}	Standby current consumption	$V_{standby} = 0$ V	-	-	15	μ A
$V_{SB out}$	Standby out threshold voltage	(Amp: on)	3.5	-	-	V
$V_{SB in}$	Standby in threshold voltage	(Amp: off)	-	-	1.5	V
A_M	Mute attenuation	$V_O = 1V_{rms}$	80	90	-	dB
$V_{M out}$	Mute out threshold voltage	(Amp: play)	3.5	-	-	V
$V_{M in}$	Mute in threshold voltage	(Amp: mute)	-	-	1.5	V
$I_m (L)$	Muting pin current	$V_{MUTE} = 1.5V$ (source current)	5	10	16	μ A
I_{CDOFF}	Clipping detector "off" output average current	THD = 1% (1)	-	100	-	μ A
I_{CDON}	Clipping detector "on" output average current	THD = 10% (1)	100	240	350	μ A

1. Diagnostics output pulled-up to 5 V with 10 k Ω series resistor.

Figure 3. Standard test and application circuit

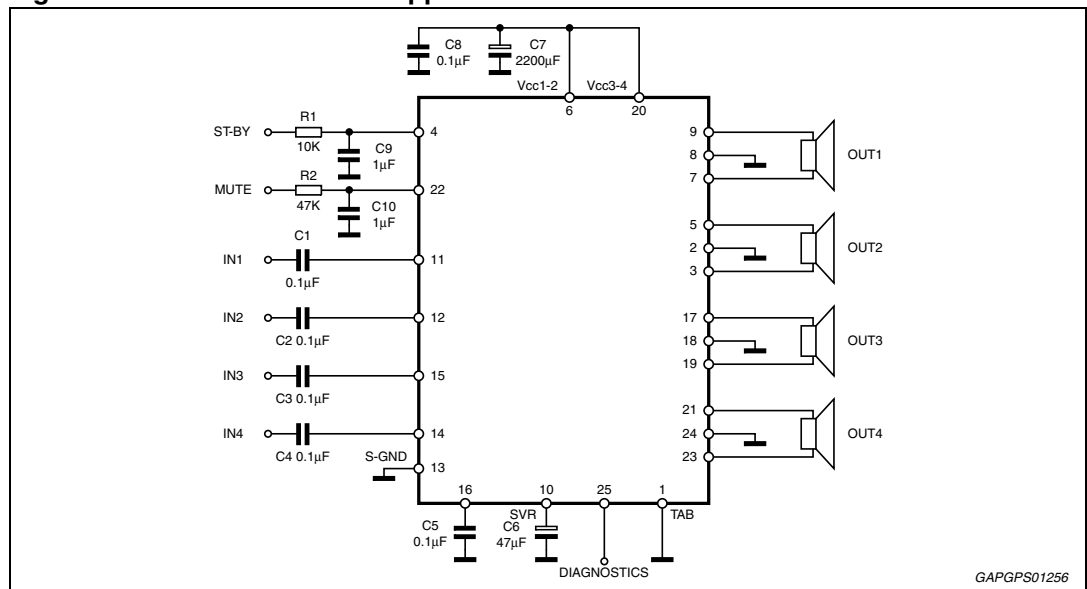

2.4 PCB and component layout

Referred to [Figure 3: Standard test and application circuit](#).

Figure 4. Components and top copper layer

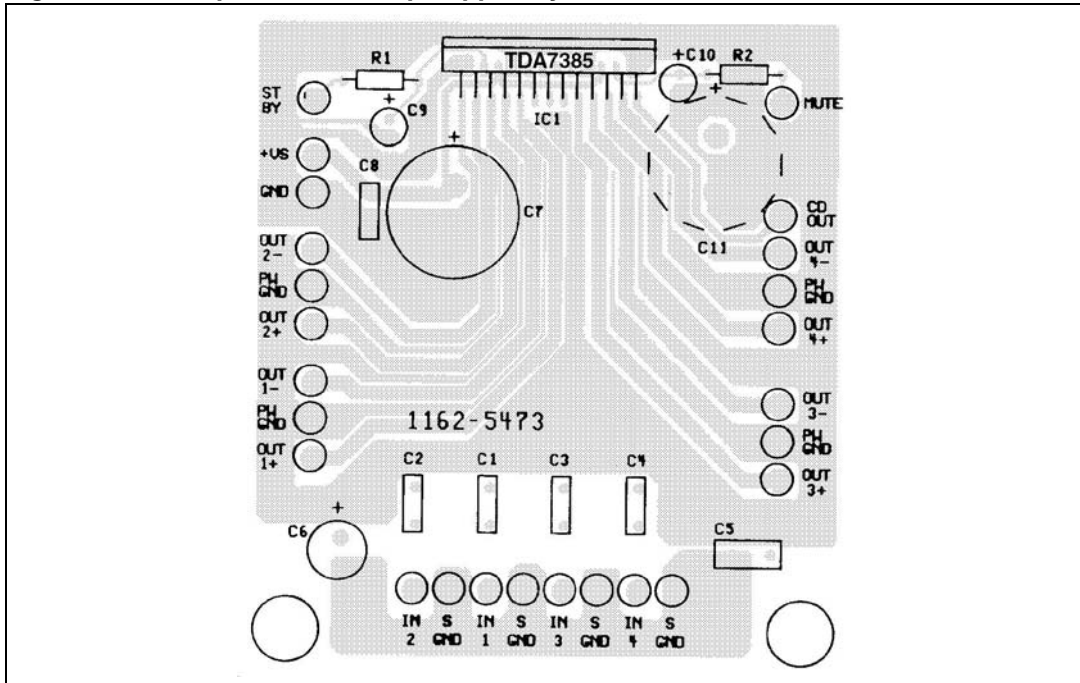
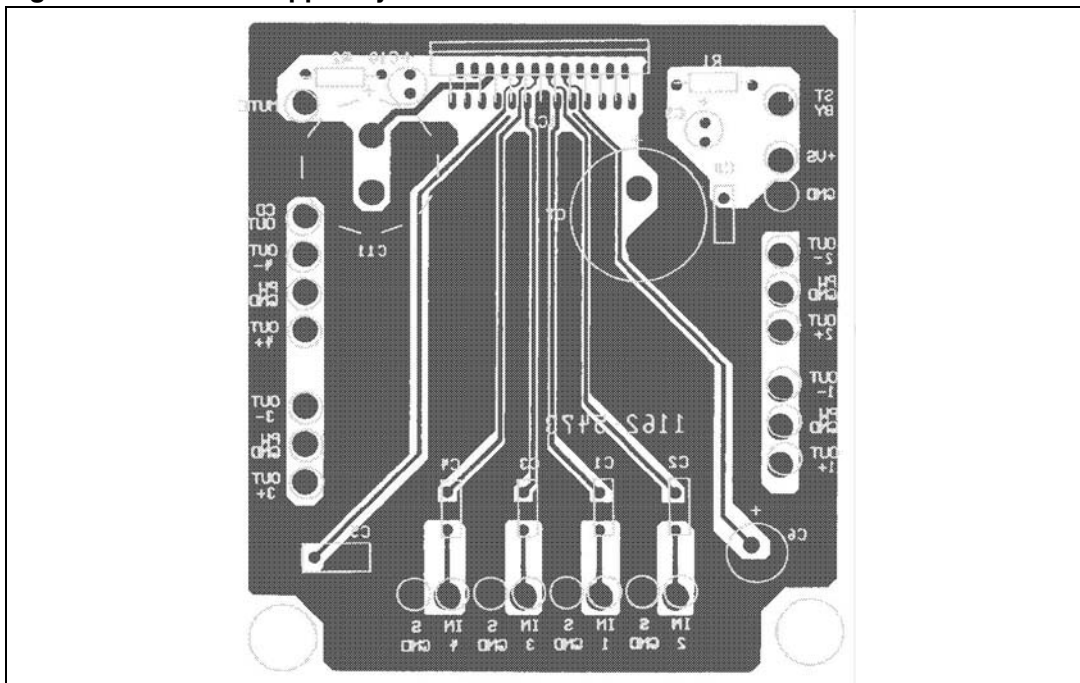

Figure 5. Bottom copper layer



2.5 Electrical characteristic curves

Figure 6. Quiescent current vs. supply voltage

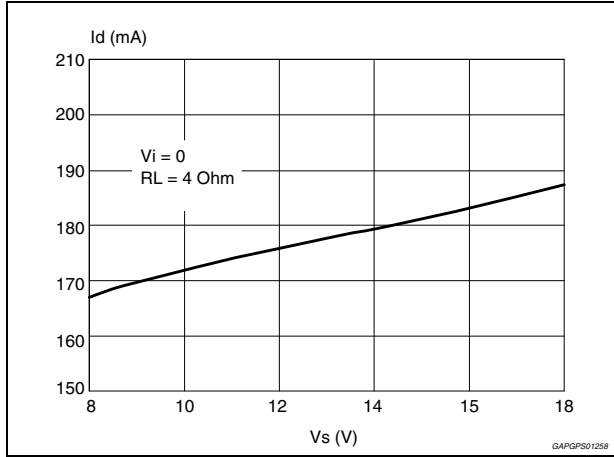

Figure 7. Quiescent output voltage vs. supply voltage

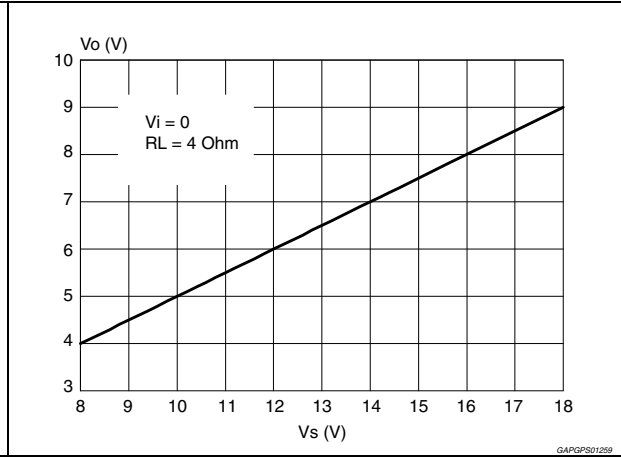

Figure 8. Output power vs. supply voltage (4Ω)

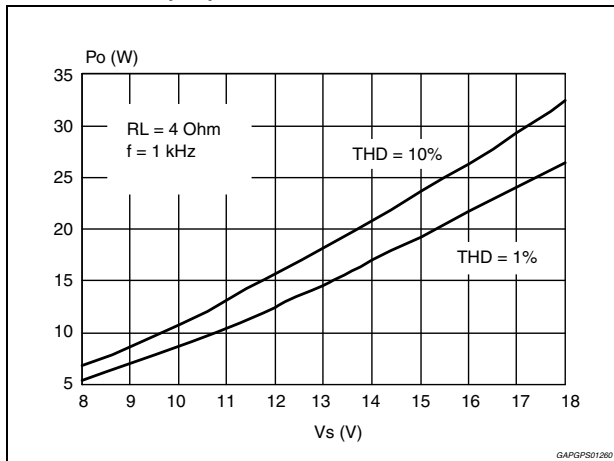

Figure 9. Distortion vs. output power

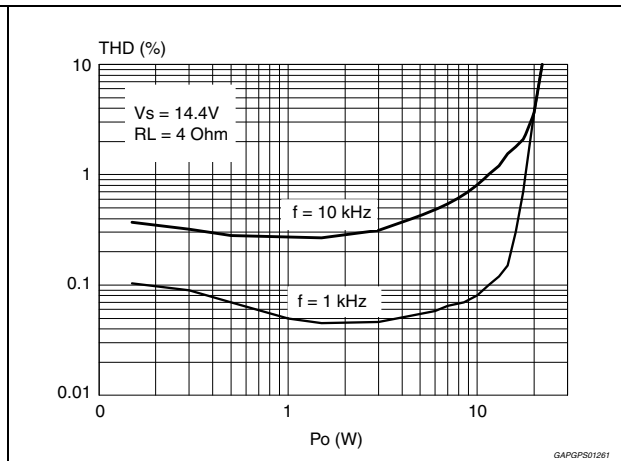

Figure 10. Distortion vs. frequency

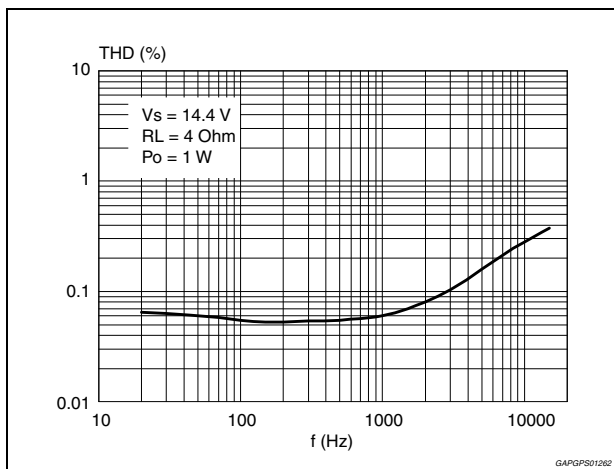

Figure 11. Supply voltage rejection vs. frequency by varying C6

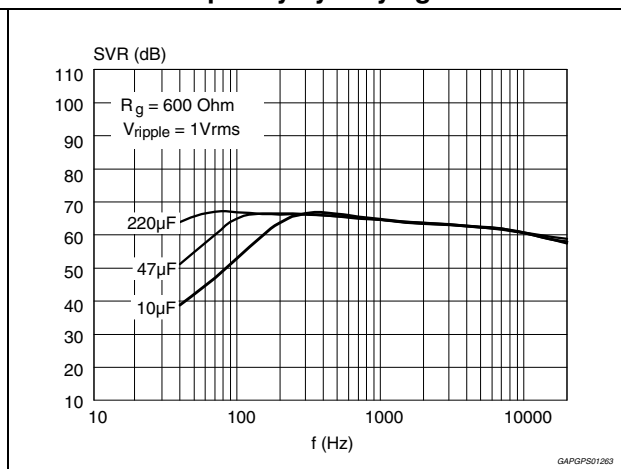
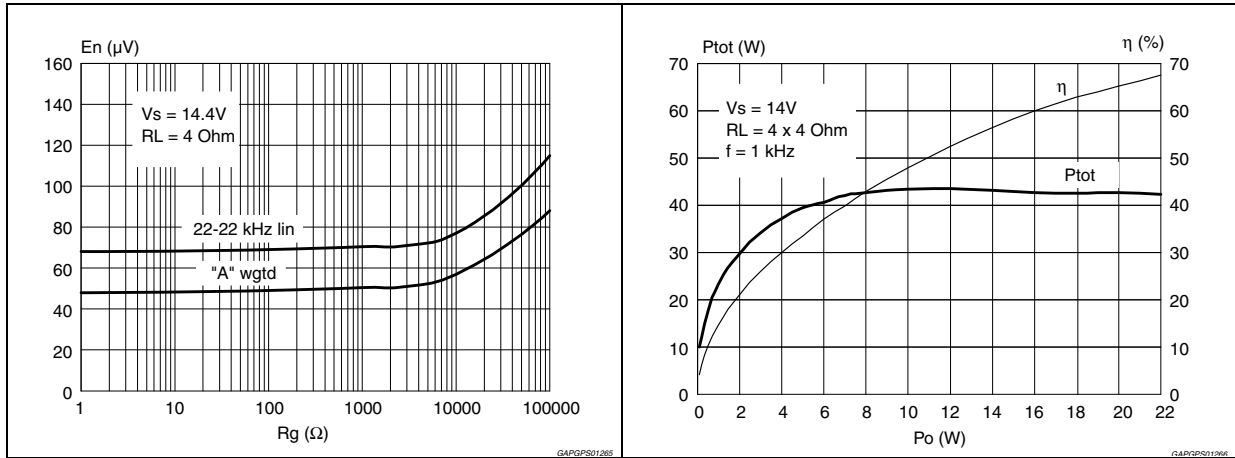

Figure 12. Output noise vs. source resistance **Figure 13. Power dissipation and efficiency vs. output power**



3 Application hints

Referred to the circuit of [Figure 3](#).

3.1 Biasing and SVR

As shown by [Figure 14](#), all the TDA7385's main sections, such as Inputs, Outputs AND AC-GND (pin 16) are internally biased at half supply voltage level ($V_s/2$), which is derived from the Supply Voltage Rejection (SVR) block. In this way no current flows through the internal feedback network. The AC-GND is common to all the 4 amplifiers and represents the connection point of all the inverting inputs.

Both individual inputs and AC-GND are connected to $V_s/2$ (SVR) by means of $100\text{ k}\Omega$ resistors.

To ensure proper operation and high supply voltage rejection, it is of fundamental importance to provide a good impedance matching between Inputs and AC-GROUND terminations. This implies that **C_1, C_2, C_3, C_4, C_5 capacitors have to carry the same nominal value and their tolerance should never exceed $\pm 10\%$** .

Besides its contribution to the ripple rejection, the SVR capacitor governs the turn ON/OFF time sequence and, consequently, plays an essential role in the pop optimization during ON/OFF transients. To conveniently serve both needs, **its minimum recommended value is $10\mu\text{F}$** .

Figure 14. Input/output biasing

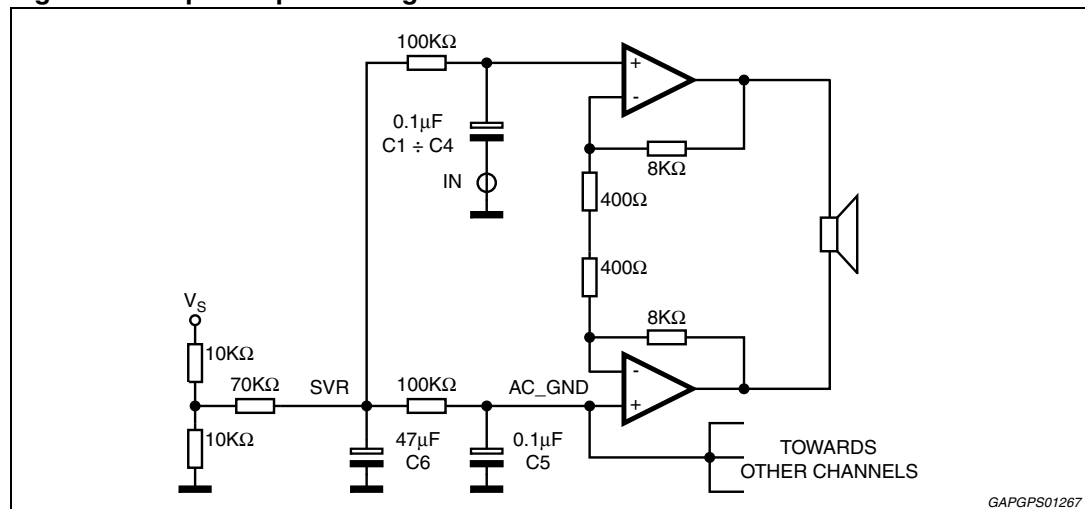

3.2 Input stage

The TDA7385's inputs are ground-compatible and can stand very high input signals ($\pm 8\text{ Vpk}$) without any performances degradation.

If the standard value for the input capacitors ($0.1\mu\text{F}$) is adopted, the low frequency cut-off will amount to 16 Hz .

3.3 Standby and muting

Standby and muting facilities are both CMOS-compatible. If unused, a straight connection to V_s of their respective pins would be admissible. Conventional low-power transistors can be employed to drive muting and stand-by pins in absence of true CMOS ports or microprocessors. R-C cells have always to be used in order to smooth down the transitions for preventing any audible transient noises.

Since a DC current of about $10\ \mu\text{A}$ normally flows out of pin 22, the maximum allowable muting-series resistance (R_2) is $70\ \text{k}\Omega$, which is sufficiently high to permit a muting capacitor reasonably small (about $1\ \mu\text{F}$).

If R_2 is higher than recommended, the involved risk will be that the voltage at pin 22 may rise to above the $1.5\ \text{V}$ threshold voltage and the device will consequently fail to turn OFF when the mute line is brought down.

About the stand-by, the time constant to be assigned in order to obtain a virtually pop-free transition has to be slower than $2.5\ \text{V/ms}$.

3.4 Diagnostics facility

The TDA7385 is equipped with a diagnostics circuitry able to detect the following events:

- Clipping in the output stage
- overheating (thermal shut-down proximity)
- Output misconnections (OUT-GND and OUT- V_s shorts)

Diagnostics information is available across an open collector output located at pin 25 ([Figure 15](#)) through a current sinking whenever at least one of the above events is recognized.

Figure 15. Diagnostics circuit

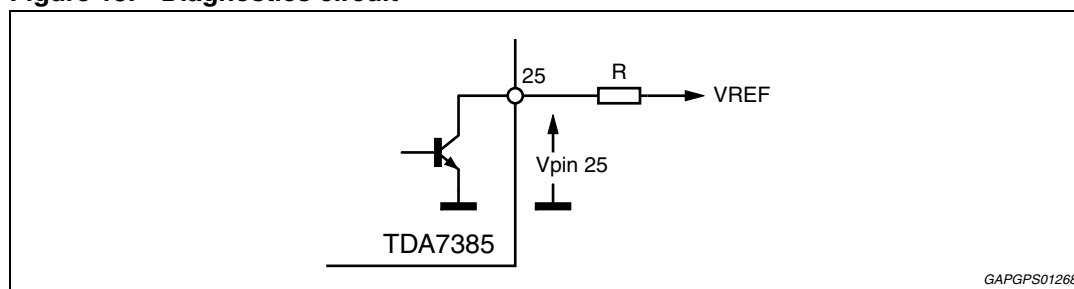

Among them, the **Clipping Detector** acts in a way to output a signal as soon as one or more power transistors start being saturated.

As a result, the clipping-related signal at pin 25 takes the form of pulses, which are perfectly synchronized with each single clipping event in the music program and reflect the same duration time ([Figure 16](#)). Applications making use of this facility usually operate a filtering/integration of the pulses train through passive R-C networks and realize a volume (or tone bass) stepping down in association with microprocessor-driven audioprocessors. The maximum load that pin 25 can sustain is $1\ \text{k}\Omega$.

Due to its operating principles, the clipping detector has to be viewed mainly as a power-dependent feature rather than frequency-dependent. This means that clipping state will be immediately signaled out whenever a fixed power level is reached, regardless of the audio

frequency. In other words, this feature offers the means to counteract the extremely sound-damaging effects of clipping, caused by a sudden increase of odd order harmonics and appearance of serious inter-modulation phenomena.

Figure 16. Clipping detection waveforms

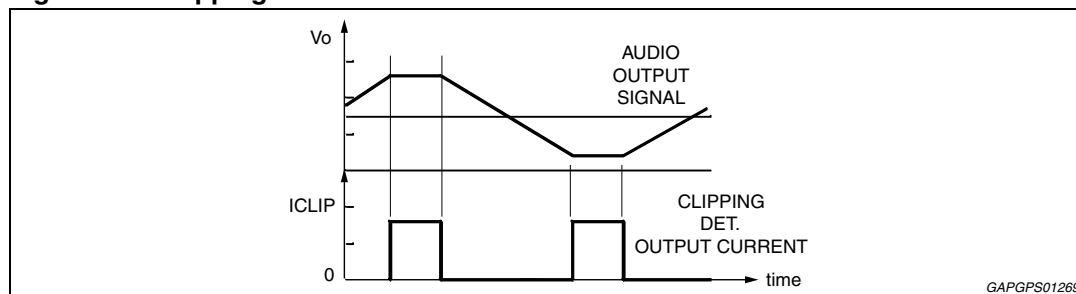

Another possible kind of distortion control could be the setting of a maximum allowable THD limit (e.g. 0.5%) over the entire audio frequency range. Besides offering no practical advantages, this procedure cannot be much accurate, as the non-clipping distortion is likely to vary over frequency.

In case of **Overheating**, pin 25 will signal out the junction temperature proximity to the thermal shut-down threshold. This will typically start about 2°C before the thermal shut-down threshold is reached.

As various kind of diagnostics information is available at pin 25 (clipping, shorts and overheating), it may be necessary to operate some distinctions in order to treat each event separately. This could be achieved by taking into account the intrinsically different timing of the diagnostics output under each circumstance.

In fact, clipping will produce pulses normally much shorter than those present under faulty conditions. An example of circuit able to distinguish between the two occurrences is shown by [Figure 18](#).

3.5 Stability and layout considerations

If properly layouted and hooked to standard car-radio speakers, the TDA7385 will be intrinsically stable with no need of external compensations such as output R-C cells. Due to the high number of channels involved, this translates into a very remarkable components saving if compared to similar devices on the market.

To simplify pc-board layout designs, each amplifier stage has its own power ground externally accessible (pins 2,8,18,24) and one supply voltage pin for each couple of them. Even more important, this makes it possible to achieve the highest possible degree of separation among the channels, with remarkable benefits in terms of cross-talk and distortion features.

About the layout grounding, it is particularly important to connect the AC-GND capacitor (C_5) to the signal GND, as close as possible to the audio inputs ground: this will guarantee high rejection of any common mode spurious signals.

The SVR capacitor (C_6) has also to be connected to the signal GND.

Supply filtering elements (C_7 , C_8) have naturally to be connected to the power-ground and located as close as possible to the Vs pins.

Pin 1, which is mechanically attached to the device's tab, needs to be tied to the cleanest power ground point in the pc-board, which is generally near the supply filtering capacitors.

Figure 17. Diagnostics waveforms

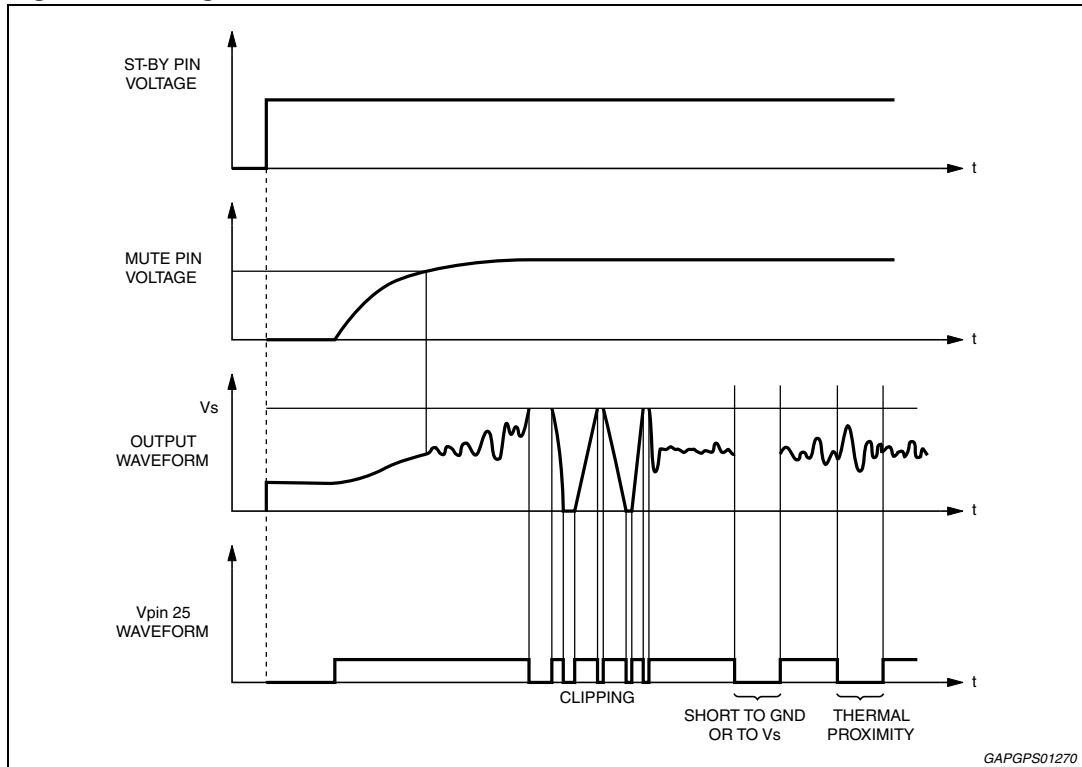
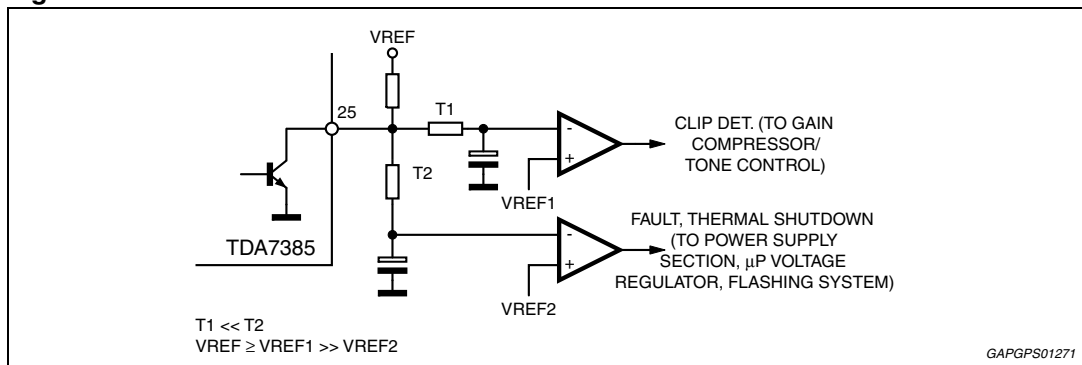

Figure 18. Fault detection circuit



4 Package information

In order to meet environmental requirements, ST offers these devices in different grades of ECOPACK® packages, depending on their level of environmental compliance. ECOPACK® specifications, grade definitions and product status are available at: www.st.com.

ECOPACK® is an ST trademark.

Figure 19. Flexiwatt25 mechanical data and package dimensions

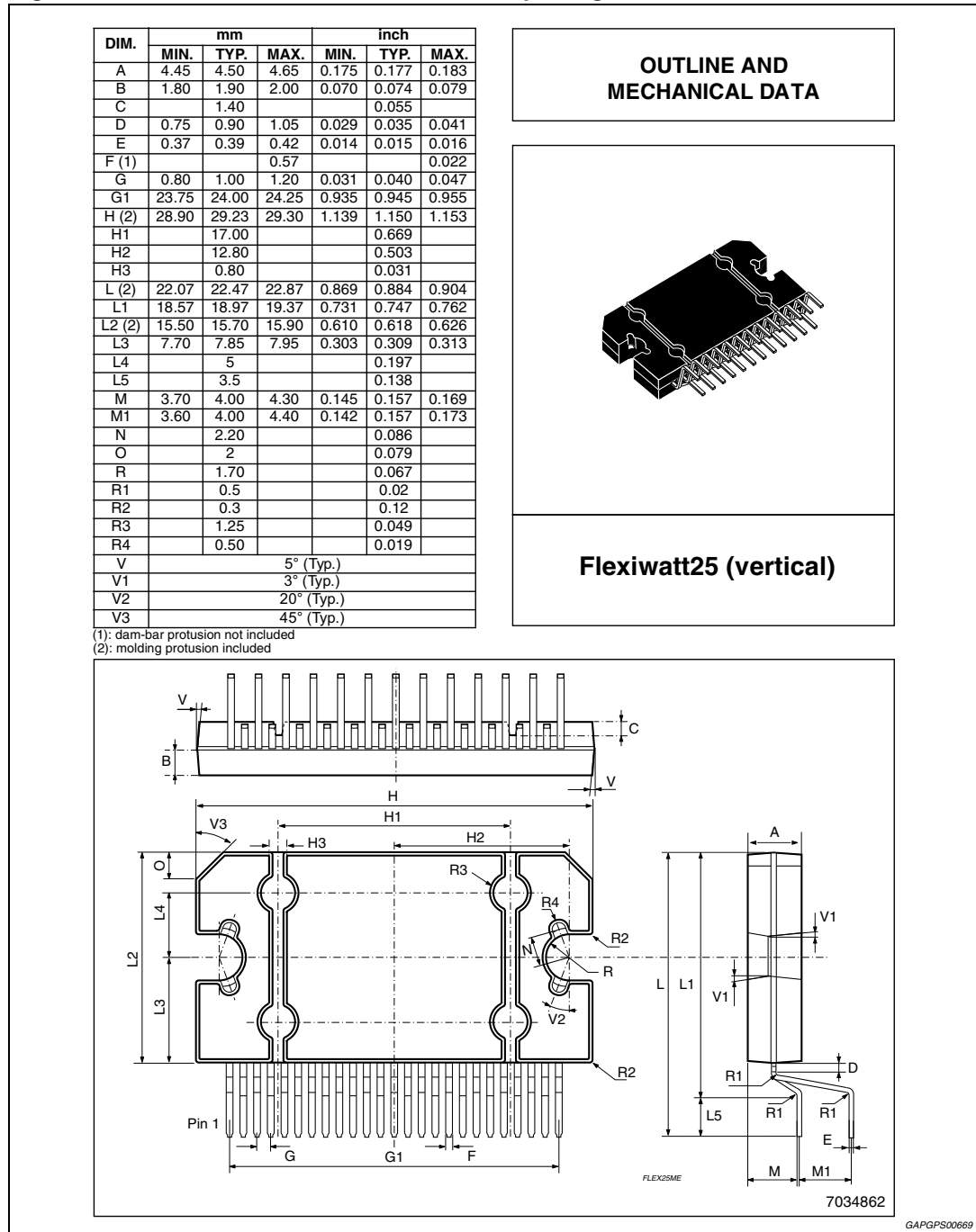

5 Revision history

Table 5. Document revision history

Date	Revision	Changes
10-Mar-2001	1	Initial release.
13-Nov-2008	2	Document reformatted. Added Features on page 1 . Updated Table 4: Electrical characteristics on page 6 . Updated Section 4: Package information on page 15 .
09-Jan-2012	3	Modified Features on page 1 ; Updated Table 4: Electrical characteristics .
14-Jun-2012	4	Updated Features on page 1 ; Updated Table 4: Electrical characteristics .
26-Jul-2012	5	Updated Figure 17: Diagnostics waveforms on page 14 .
16-Sep-2013	6	Updated Disclaimer.