Interface circuit (relay and lamp driver)

Features

- High output current
- Adjustable short-circuit protection to ground
- Internal thermal protection with hysteresis to avoid the intermediate output levels
- Large supply voltage range: 8 to 30V
- Short-circuit protection to V_{CC}
- Open ground protection

Description

The TDE3247 is a monolithic amplifier designed for high current and high voltage applications, specifically to drive lamps, relays and stepping motors.

The Device is essentially blow-out proof. Current limiting is available to limit the peak output current to a safe value, the adjustment only required an external resistor.

In addition, thermal shut-down is provided to keep the IC from overheating.

If external dissipation becomes too high, the driver will shut-down to prevent excessive heating.

The output is also protected against short-circuit with the positive power supply.

The device operates over a wide range of supply voltage from standard $\pm 15V$ operational amplifier supplies down to the single 12V or 24V used for industrial electronic systems.

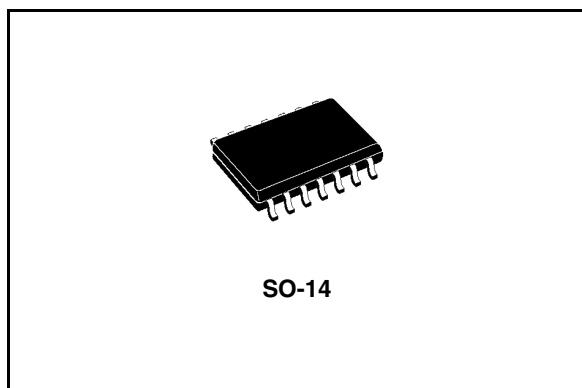
**Order codes**

Part number	Package	Packaging
TDE3247FP	SO-14	Tube
TDE3247FPT	SO-14	Tape & Reel

Contents

1	Schematic diagram and pin connections	3
2	Electrical ratings	4
3	Electrical characteristics	5
3.1	Electrical characteristics (curves)	6
4	Application circuit	8
5	Package mechanical data	9
6	Revision history	14

1 Schematic diagram and pin connections

Figure 1. Schematic diagram

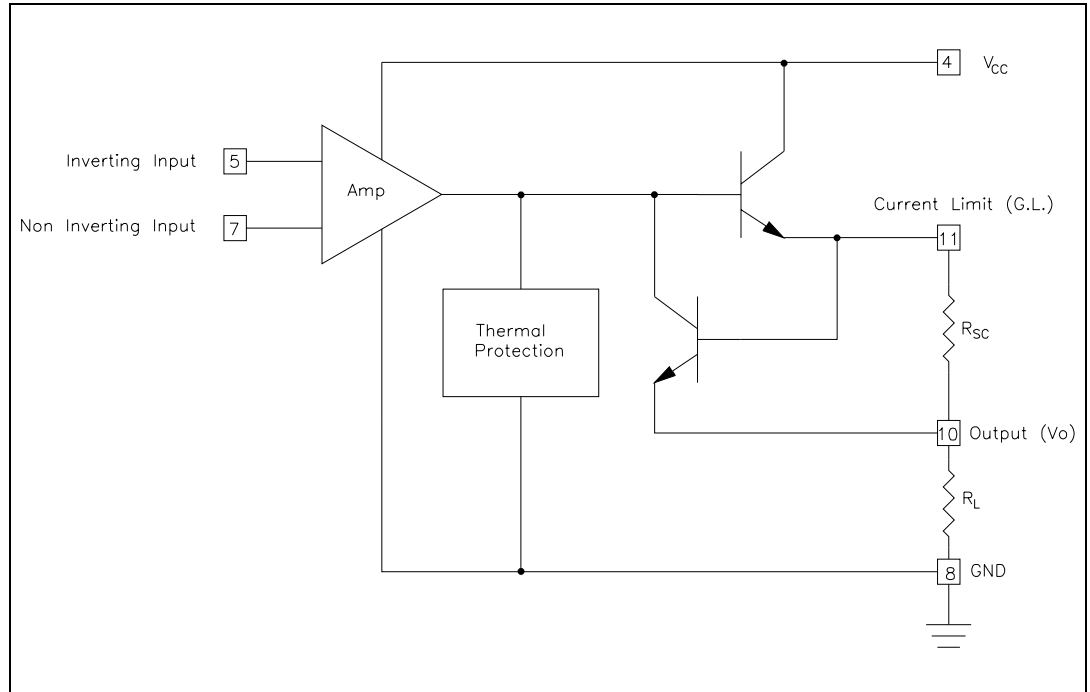
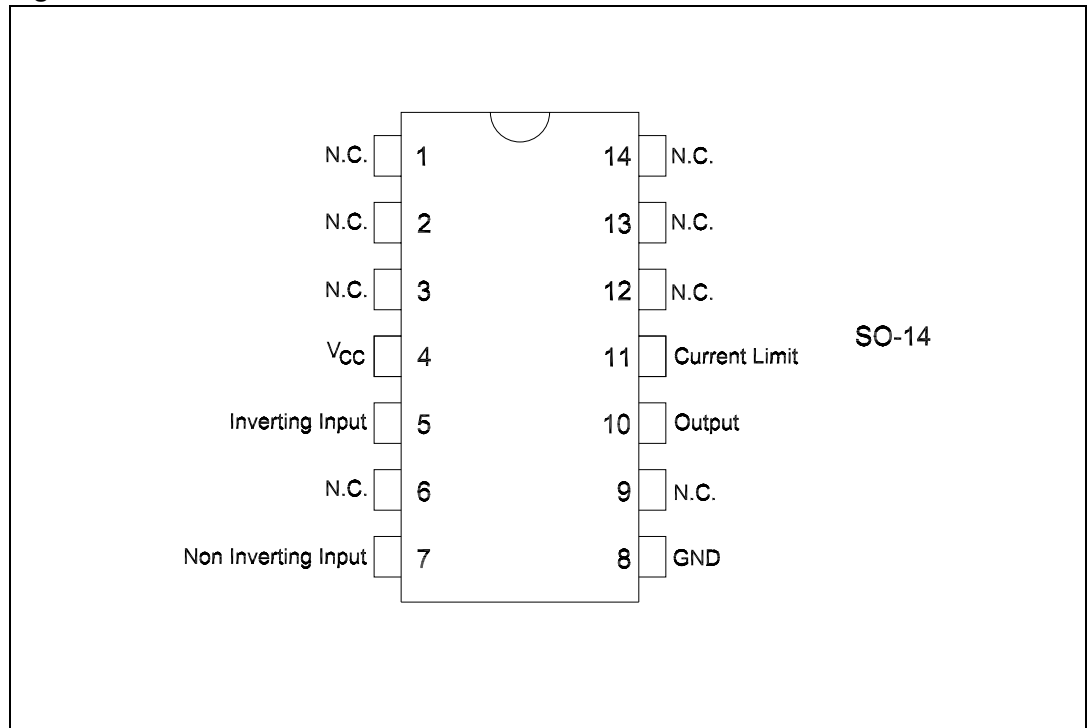

Figure 2. Pin connections



2 Electrical ratings

Table 1. Absolute maximum ratings

Symbol	Parameter	Value	Unit
V_{CC}	Supply Voltage	36	V
V_O	Differential Input Voltage	36	V
V_I	Input Voltage	36	V
I_O	Output Current	300	mA
P_{TOT}	Power Dissipation	Internally limited	W
T_{oper}	Ambient Temperature Range	-25 to 85	°C
T_{STG}	Storage Temperature Range	-65 to +150	°C

Table 2. Thermal data

R_{th}	Junction-ceramic Substrate (case glued to substrate) For SO-14	90	°C/W
R_{th}	Junction-ceramic Substrate (case glued to substrate, substrate temperature maintained constant) For SO-14	65	°C/W

3 Electrical characteristics

($-25^{\circ}\text{C} \leq T_A \leq 85^{\circ}\text{C}$, $8\text{V} \leq V_{CC} \leq 30\text{V}$, $I_O \leq 150\text{mA}$, $T_J \leq 150^{\circ}\text{C}$, unless otherwise specified) *Note: 1*

Table 3. Electrical characteristics

Symbol	Parameter	Test Conditions	Min.	Typ.	Max.	Unit
V_{IO}	Input Offset Voltage	<i>Note 2</i>		2	50	mV
I_{IB}	Input Bias Current			0.1	1.5	μA
I_{CC}	Supply Current	$V_{CC} = 24\text{V}$, $I_O = 0\text{A}$, $T_{\text{amb}} = 25^{\circ}\text{C}$				
		High Level		4	10	mA
		Low Level		2		mA
V_{CM}	Common Mode Input Voltage Range		2		$V_{CC}-2$	V
I_{SC}	Short-circuit Current	$V_{CC} = 24\text{V}$, $T_{\text{amb}} = 25^{\circ}\text{C}$ $R_{SC} = 3.3\Omega$		250		mA
$V_{CC} - V_O$	Output Saturation Voltage (Output High)	$(V_{I^+} - V_{I^-}) \leq 50\text{mV}$ $I_O = 150\text{mA}$, $R_{SC} = 0$ $T_J = 25^{\circ}\text{C}$		1.2	1.8	V
I_{OL}	Output Leakage Current (Output Low)	$V_O = 0\text{V}$, $V_{CC} = 24\text{V}$				
		$T_J = 25^{\circ}\text{C}$		1	100	μA
		$T_J = 85^{\circ}\text{C}$			500	μA
I_{OS}	Minimum Short-current Output Current	$T_{\text{amb}} = 25^{\circ}\text{C}$, $V_{CC} = 24\text{V}$ $R_{SC} = \infty$		50		mA

- Note:*
- 1 For operating at high temperatures, the device must be derated based on a 150°C maximum junction and a junction to ambient thermal resistance of $110^{\circ}\text{C}/\text{W}$
 - 2 The offset voltage given in the maximum value of input voltage required to drive the output voltage within 2V of the ground or the supply voltage.

3.1 Electrical characteristics (curves)

Figure 3. Available output current vs. limiting resistor

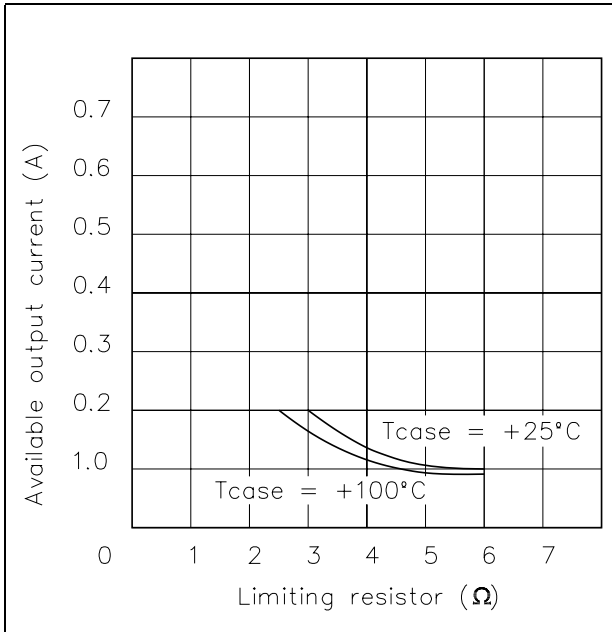

Figure 4. Supply current vs. junction temperature

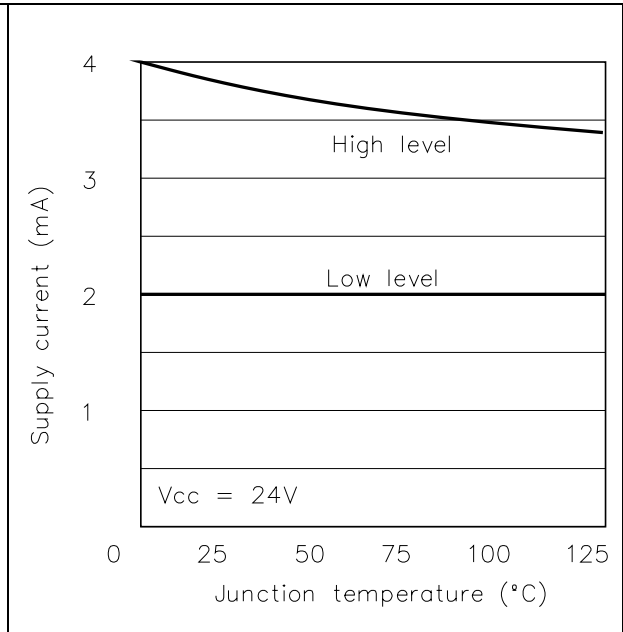

Figure 5. Saturation output voltage vs. case temperature and available output current

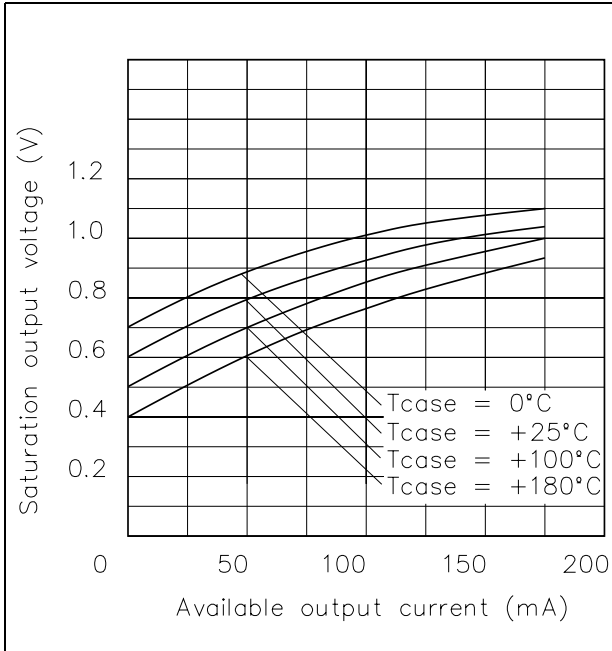

Figure 6. Supply current vs. supply voltage

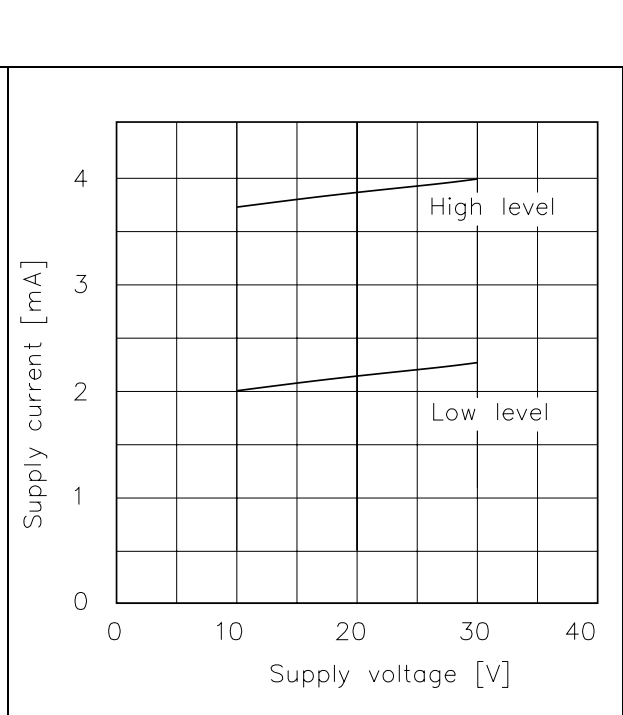

Figure 7. Supply voltage vs. minimum limiting resistor value **Figure 8. Response time**

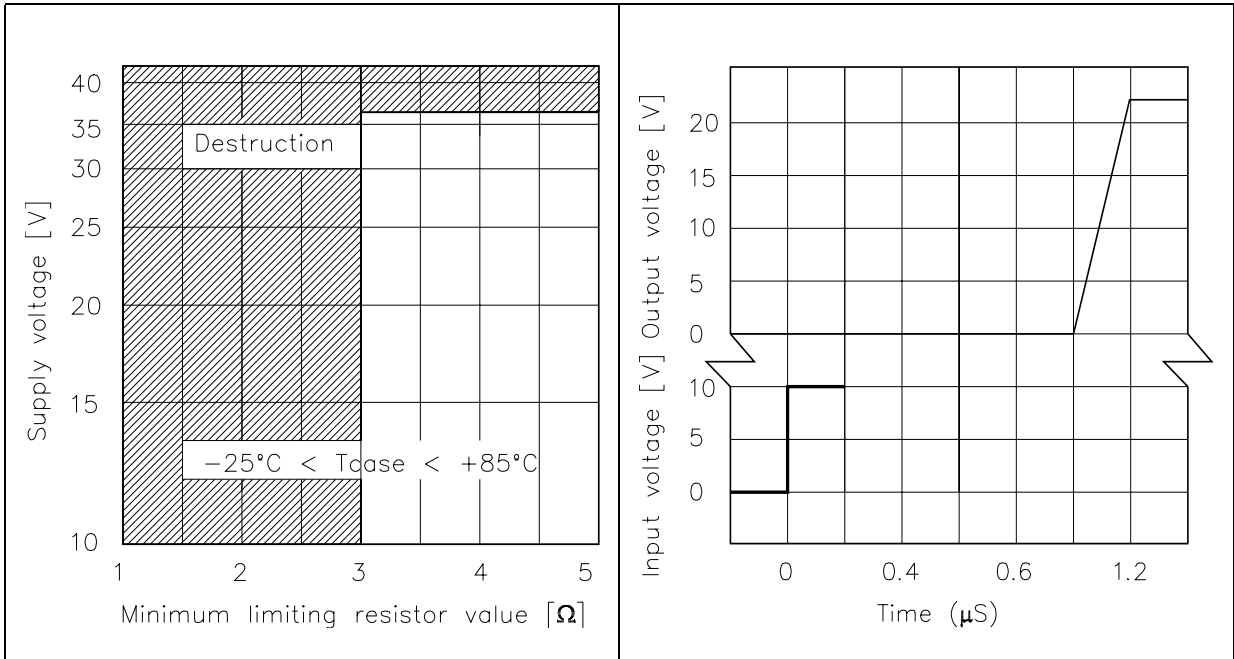
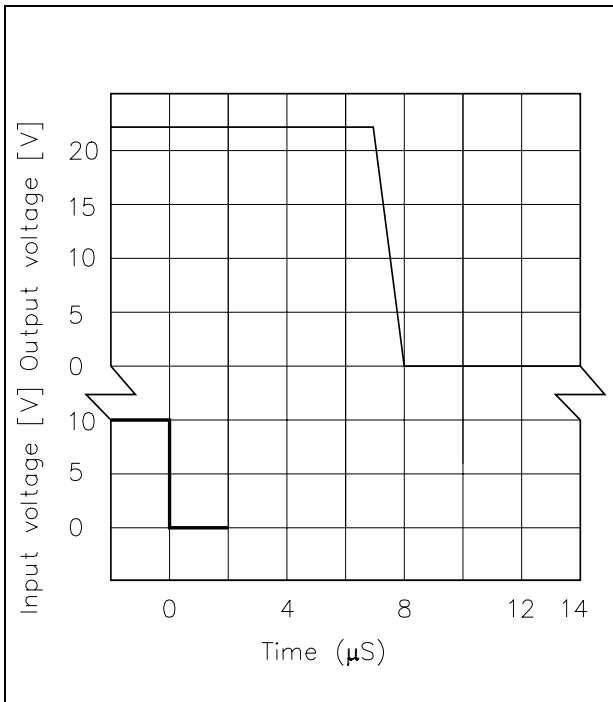

Figure 9. Response time



4 Application circuit

Figure 10. Basic application circuit

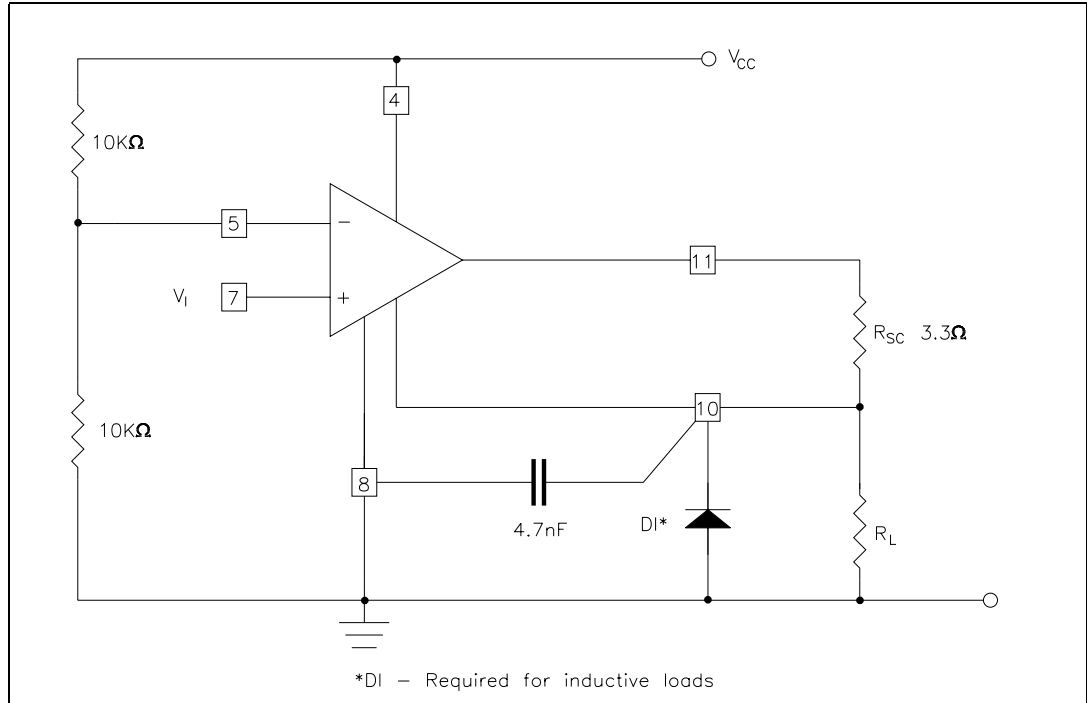
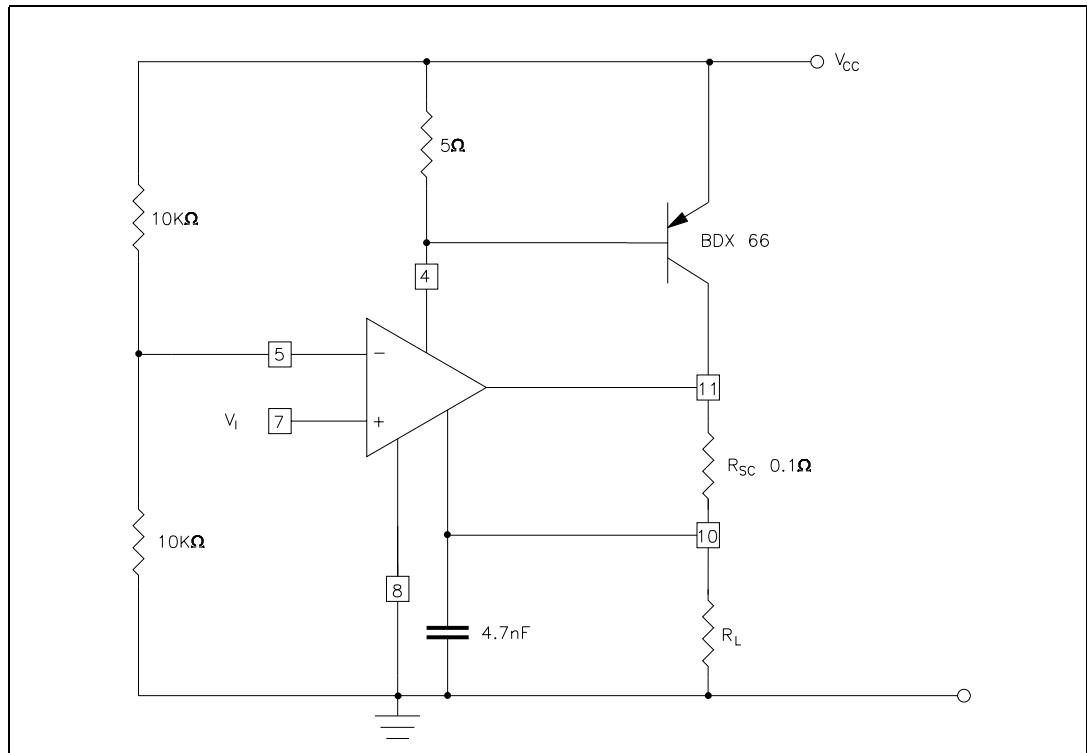

Figure 11. Output current boosting (5A)



5 Package mechanical data

In order to meet environmental requirements, ST offers these devices in ECOPACK® packages. These packages have a Lead-free second level interconnect. The category of second level interconnect is marked on the package and on the inner box label, in compliance with JEDEC Standard JESD97. The maximum ratings related to soldering conditions are also marked on the inner box label. ECOPACK is an ST trademark. ECOPACK specifications are available at: www.st.com

Table 4. SO-14 Mechanical data

Dim.	mm.			inch		
	Min.	Typ	Max.	Min.	Typ.	Max.
A			1.75			0.068
a1	0.1		0.2	0.003		0.007
a2			1.65			0.064
b	0.35		0.46	0.013		0.018
b1	0.19		0.25	0.007		0.010
C		0.5			0.019	
c1	45° (typ.)					
D	8.55		8.75	0.336		0.344
E	5.8		6.2	0.228		0.244
e		1.27			0.050	
e3		7.62			0.300	
F	3.8		4.0	0.149		0.157
G	4.6		5.3	0.181		0.208
L	0.5		1.27	0.019		0.050
M			0.68			0.026
S	8° (max.)					

Figure 12. Package dimensions

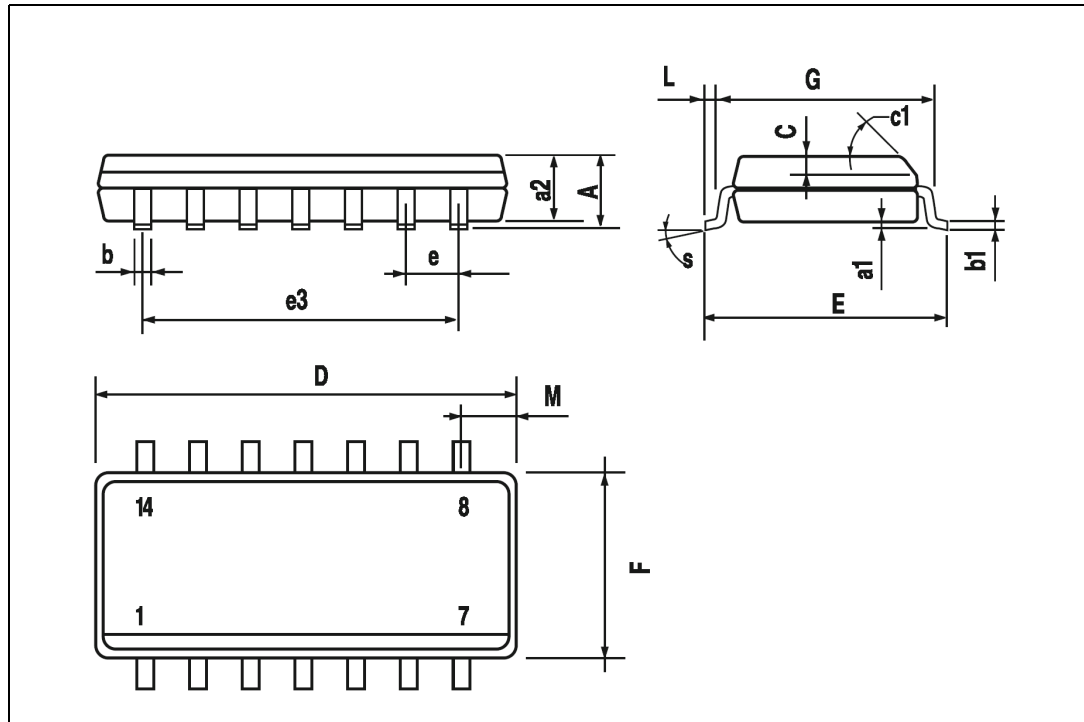

Table 5. Tube shipment information

Tube mechanical data		
	mm.	inch.
A	6.60 ±0.10	0.260 ±0.004
B	1.90 ±0.10	0.075 ±0.004
C	0.60 ±0.10	0.024 ±0.004
D	7.80 ±0.10	0.307 ±0.004
E	4.30 ±0.10	0.169 ±0.004
BASE QUANTITY	100 pcs.	
BULK QUANTITY	2000 pcs.	

Figure 13. Tube dimension

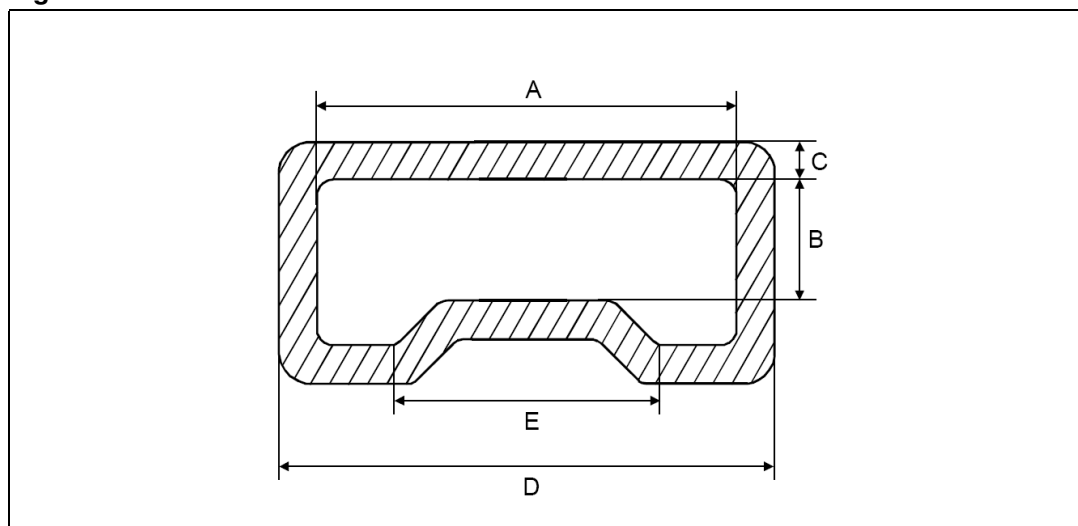

Table 6. Tape & reel shipment information

Tape mechanical data		
	mm.	inch
D	1.50 +0.1/0	0.059 +0.004/0
E	1.75 ±0.1	0.069 ±0.004
Po	4.00 ±0.1	0.157 ±0.004
T max.	0.40	0.016
D1 min.	1.50	0.059
F	7.5 ±0.05	0.295 ±0.002
K max.	6.50	0.256
P2	2.00 ±0.05	0.079 ±0.002
R	40	1.575
W	16.00 ±0.30	0.630 ±0.012
P1	12.00	0.472
Ao, Bo, Ko	0.05 min to 0.90 max.	0.002 min to 0.035 max.

Figure 14. Tape specification

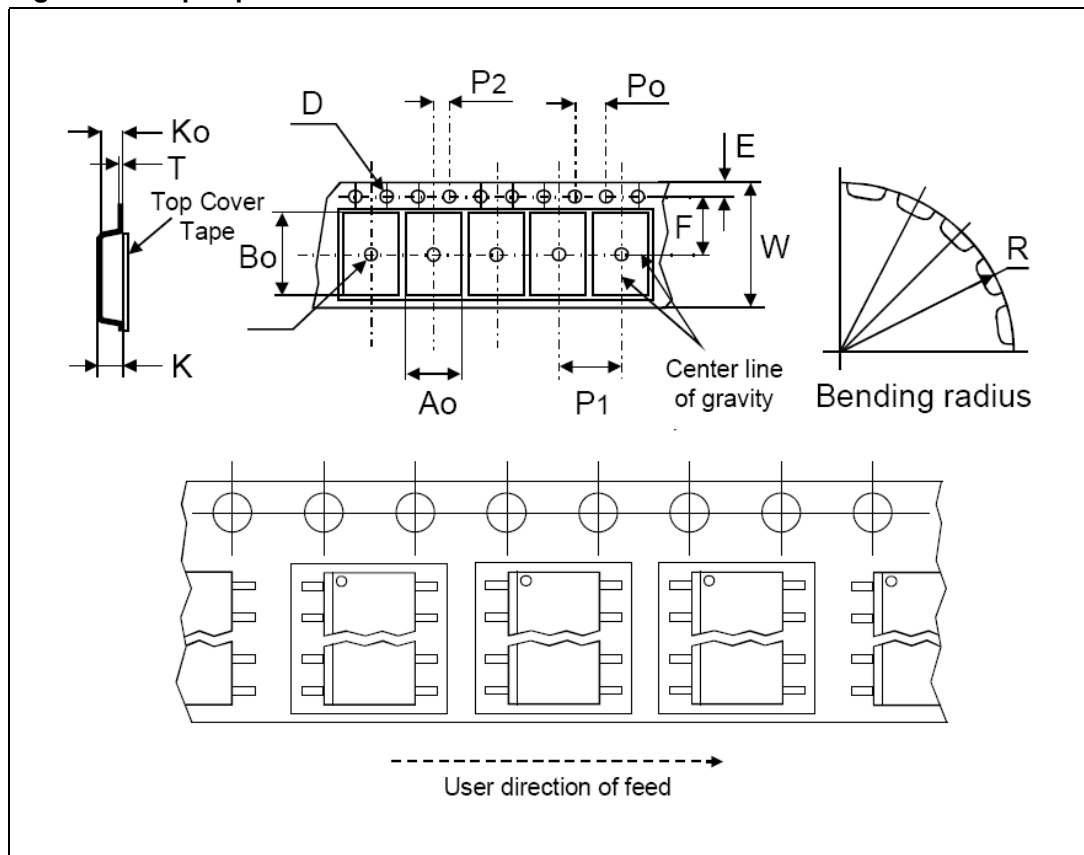
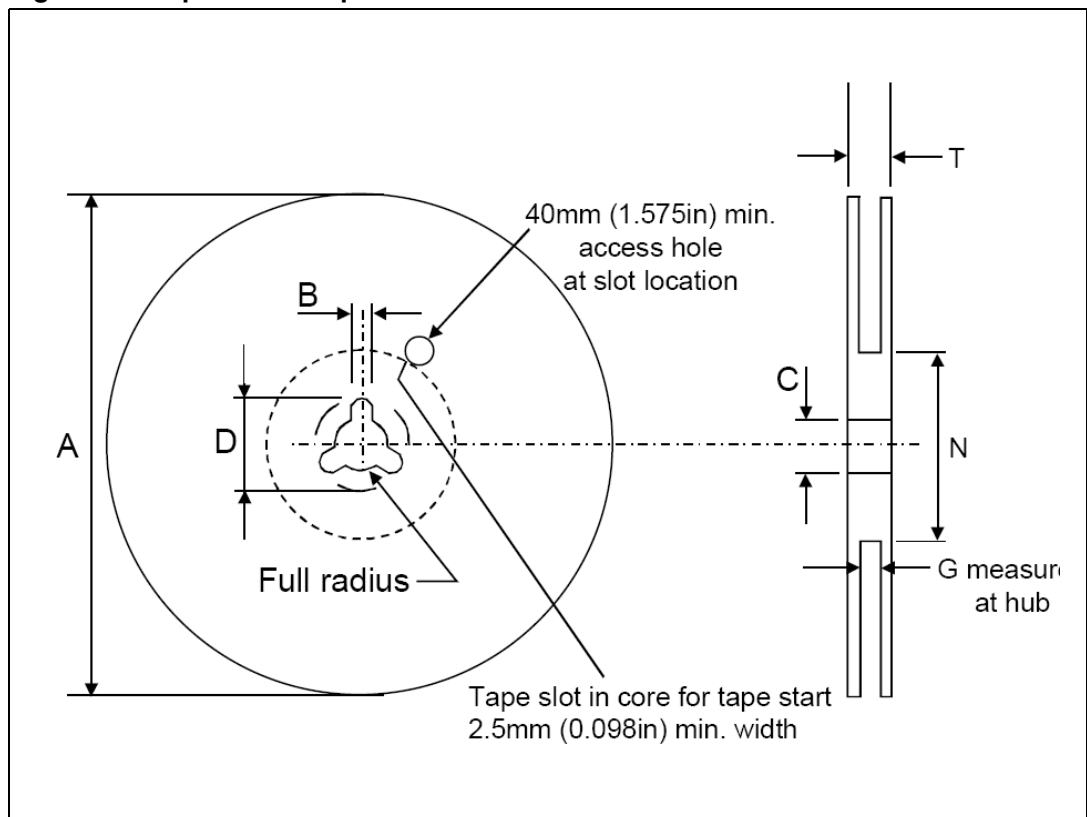

Table 7. Reel mechanical data

	mm.	inch
Tape size	16.0 ±0.30	0.630 ±0.012
A max.	330.0	12.992
B min.	1.5	0.059
C	13.0 ±0.20	0.512 ±0.008
D min.	20.2	0.795
N min.	60	2.362
G	16.4 +2/-0	0.646 +0.079/-0
T max.	22.4	0.882

Figure 15. Tape & reel shipment information



6 Revision history

Table 8. Revision history

Date	Revision	Changes
20-Apr-2006	1	First release
27-Jun-2006	2	Typo in cover page