



UM10727

GreenChip TEA1708T automatic discharge for X capacitors demo board

Rev. 1 — 3 October 2013

User manual

Document information

Info	Content
Keywords	TEA1708T, APBADC073, discharge, X capacitor, SO8, low power consumption, discharge current, surge protection, demo board
Abstract	<p>This user manual describes how the TEA1708T APBADC073 demo board can be used in a power converter to add the automatic discharge for X capacitor functionality. It also provides recommendations for integration of the TEA1708T in a power adapter printed-circuit board. The demo board contains a TEA1708T controller in SO8 package and two resistors and one capacitor.</p> <p>The APBADC073 demo board replaces the resistors that are normally used to discharge the X capacitor. It can be connected directly across the X capacitor terminals for evaluation purposes.</p>



Revision history

Rev	Date	Description
v.1	20131003	first issue

Contact information

For more information, please visit: <http://www.nxp.com>

For sales office addresses, please send an email to: salesaddresses@nxp.com

1. Introduction

WARNING

Lethal voltage and fire ignition hazard



The non-insulated high voltages that are present when operating this product, constitute a risk of electric shock, personal injury, death and/or ignition of fire.

This product is intended for evaluation purposes only. It shall be operated in a designated test area by personnel qualified according to local requirements and labor laws to work with non-insulated mains voltages and high-voltage circuits. This product shall never be operated unattended.

This document describes the TEA1708T APBADC073 demo board. A functional description is provided, supported by a small set of measurements illustrating the performance of the TEA1708T. The demo board can be used standalone or can be hooked up to an existing power supply to demonstrate the capabilities of the TEA1708T.

All values in this user manual are typical values, unless otherwise specified.

2. Safety warnings

The board must be connected to the mains voltage. Touching the board during operation must always be avoided. An isolated housing is obligatory when used in uncontrolled, non-laboratory environments. A galvanic isolation of the mains phase using a variable transformer is always recommended. The symbols shown in [Figure 1](#) indicate these devices.

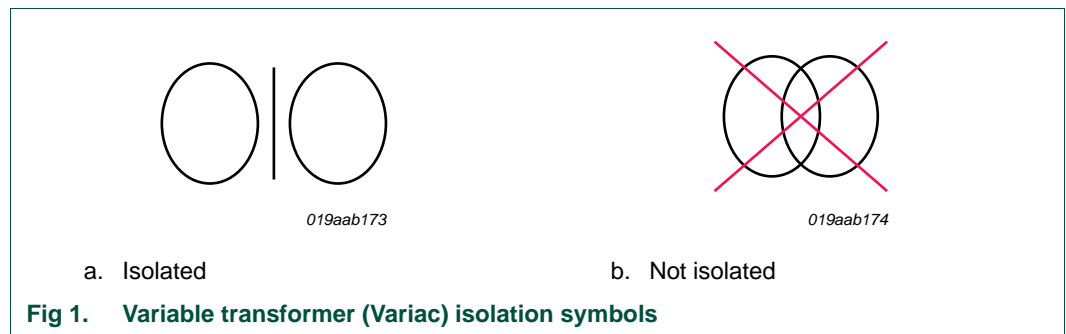

3. Specification

Table 1. Input specification

Parameter	Conditions	Value	Comment
input voltage		85 V (AC) to 265 V (AC)	universal mains
input frequency		47 Hz to 63 Hz	
input power		< 1 mW	Power consumption without X capacitor

4. Functional description

The TEA1708T is an automatic discharge IC for X capacitors. It has a low power consumption (< 1 mW at 230 V (AC)). The X-capacitor discharge current is internally limited to 2.3 mA. The discharge delay time is set externally by using a low voltage capacitor.

A 500 V clamping circuit is integrated, which protects the IC during mains surges.

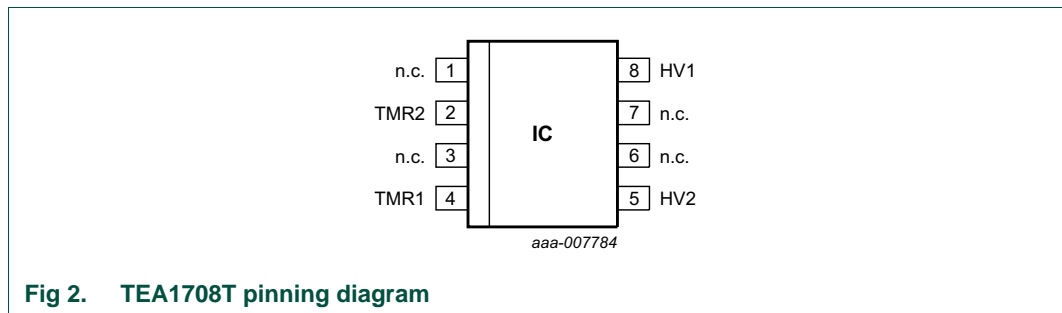

Fig 2. TEA1708T pinning diagram

5. Demo board setup

The APBADC073 demo board is designed so it can easily be added across the terminals of the X capacitor in the existing power supply converter. It can also directly substitute the X capacitor of the existing power supply when the X capacitor is mounted on the TEA1708T demo board.

5.1 Demo board APBADC073

The APBADC073 demo board consists of the TEA1708T in an SO8 package, two 200 k Ω discharge resistors, a 10 nF timer capacitor, and a 1 μ F X2 capacitor. [Figure 3](#) shows the front and back side of the demo board.

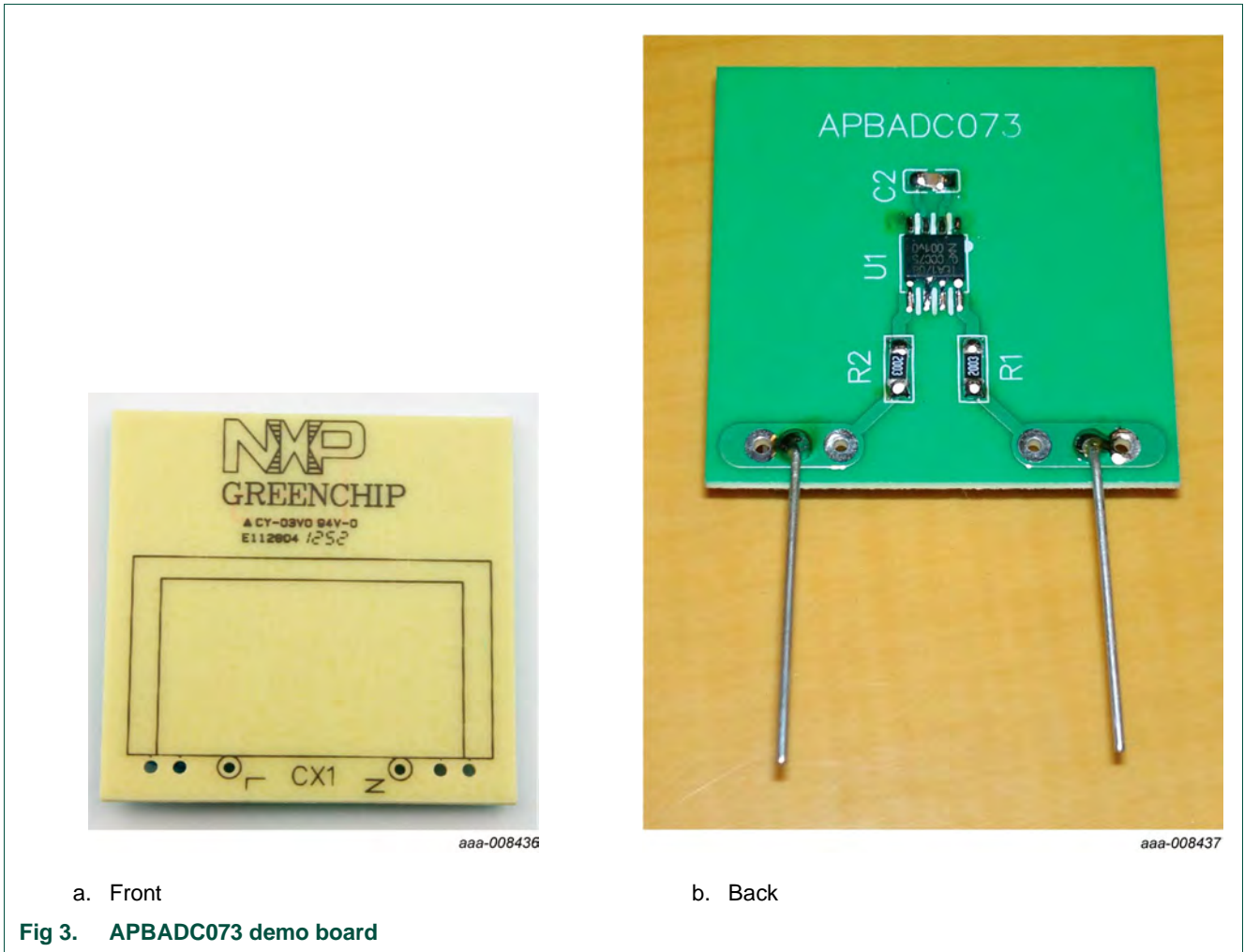

5.2 Connecting the board

The APBADC073 demo board can be directly connected across the X capacitor terminals of the power supply. Either the original X capacitor of the power supply or the X capacitor of the board can be used. Remove the discharge resistors of the original application.

Figure 4 shows the board connections.

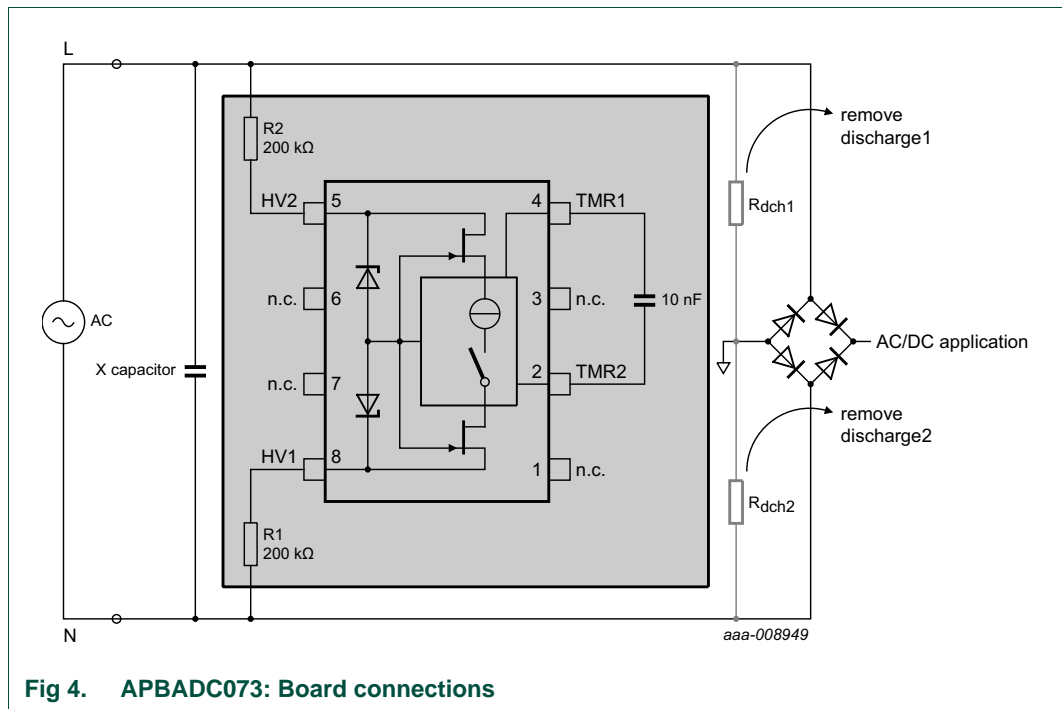

Fig 4. APBADC073: Board connections

6. Measurements

Tests have been carried out to measure the power consumption of the TEA1708T, to test the discharge capacity of the TEA1708T, and to test the surge capability.

6.1 Test setup

The board has been tested standalone.

6.1.1 Test equipment

- AC source: Agilent 6812B
- Power meter: Yokogawa WT210 with harmonics option
- Digital oscilloscope: Yokogawa DL1640L
- 100 MHz, high-voltage differential probe: Yokogawa 700924
- Multimeter: Keithley 2000
- KeyTek EMCP Pro Plus

6.1.2 Test conditions

- Ambient temperature between 20 °C and 25 °C

6.2 Power consumption

Test conditions:

The APBAD073 demo board is connected to the AC source. The X capacitor must not be connected. For several AC voltages the power consumption is measured with the power meter set to the lowest current value (5 mA), integration time of 36 s, and readout in mWh. The results are given in [Table 2](#).

Table 2. Power consumption TEA1708T

V (AC)/60 Hz	Pin	Comments
85 V	0.27 mW	ambient
115 V	0.37 mW	ambient
230 V	0.75 mW	ambient
265 V	0.87 mW	ambient

6.3 Discharge capacity

Test conditions:

The board with the 1 μF X capacitor is connected to the AC source (230 V (AC)/50 Hz). A differential probe is directly connected across the terminals of the X capacitor. When the AC source is disconnected, the TEA1708T starts to discharge the X capacitor through resistors R1 and R2 (both 200 kΩ). [Figure 5](#) shows the discharge curve.

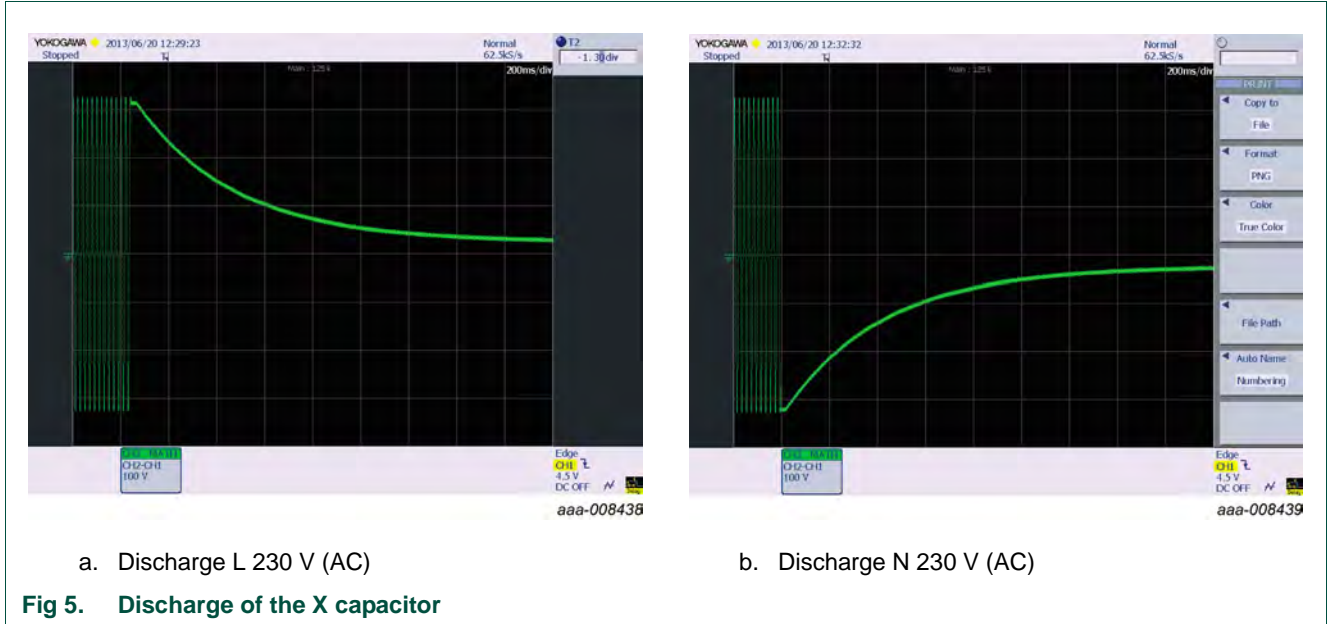

[Table 3](#) shows the time that is required to discharge the X capacitor for three different values of this X capacitor.

Table 3. Discharge time

X capacitor value (nF)	Discharge time (135 V) (ms)	Discharge time (60 V) (ms)
470	200	420
1000	420	870
2000	810	1700

6.4 Surge capability

Test conditions:

- The APBADC073 demo board without the X capacitor is connected to the surge generator KeyTek EMCPPro Plus
- The applied voltage (AC) is 230 V/50 Hz
- Resistors R1 and R2 are both 200 k Ω . In total 6 x 68 k Ω is used to ensure that the resistors are not damaged by the high-voltage surge pulses.

Surge testing requirements: IEC61000-4-5.

Table 4. Setup for surge testing

Parameter	Setting 1	Setting 2	Setting 3
waveform	SRG 1.2/50	user defined	2 Ω
surge pulses	1, 2, 4, 6 kV		
output coupling	mains L, N		
phase reference	0, 90, 180, 270 $^\circ$		
number of tests	5		
time between tests	15 s		

Table 5. Surge test results

Surge voltage	R1, R2 (k Ω)	Result	Comments
1 kV/90 $^\circ$	200	pass	230 V/50 Hz; differential L to N
2 kV/90 $^\circ$	200	pass	230 V/50 Hz; differential L to N
4 kV/90 $^\circ$	200	pass	230 V/50 Hz; differential L to N
6 kV/0 $^\circ$	200	pass	230 V/50 Hz; differential L to N
6 kV/90 $^\circ$	200	pass	230 V/50 Hz; differential L to N
6 kV/180 $^\circ$	200	pass	230 V/50 Hz; differential L to N
6 kV/270 $^\circ$	200	pass	230 V/50 Hz; differential L to N

7. Schematic

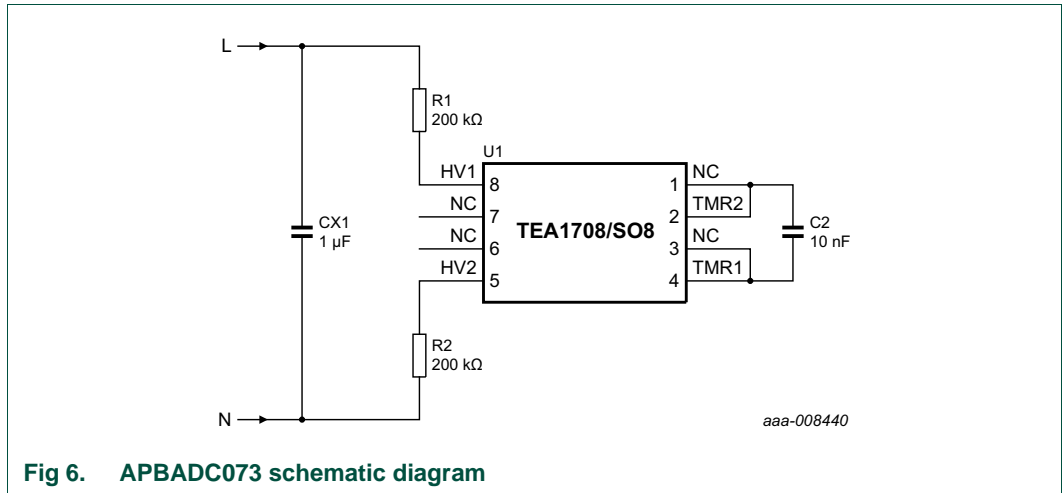

Fig 6. APBADC073 schematic diagram

On the demo board, pin 1 (NC) and pin 2 (TMR2) are connected. Pin 3 (NC) and pin 4 (TMR1) are also connected. The reason for this is backward compatibility with earlier (test) versions of the TEA1708T.

For final application designs with the TEA1708T, leave pin 1 and pin 3 open. Connect capacitor C2 only to pin 2 (TMR2) and pin 4 (TMR1), as this eliminates the risk of malfunctioning as a result of accidentally soldering together two adjacent pins.

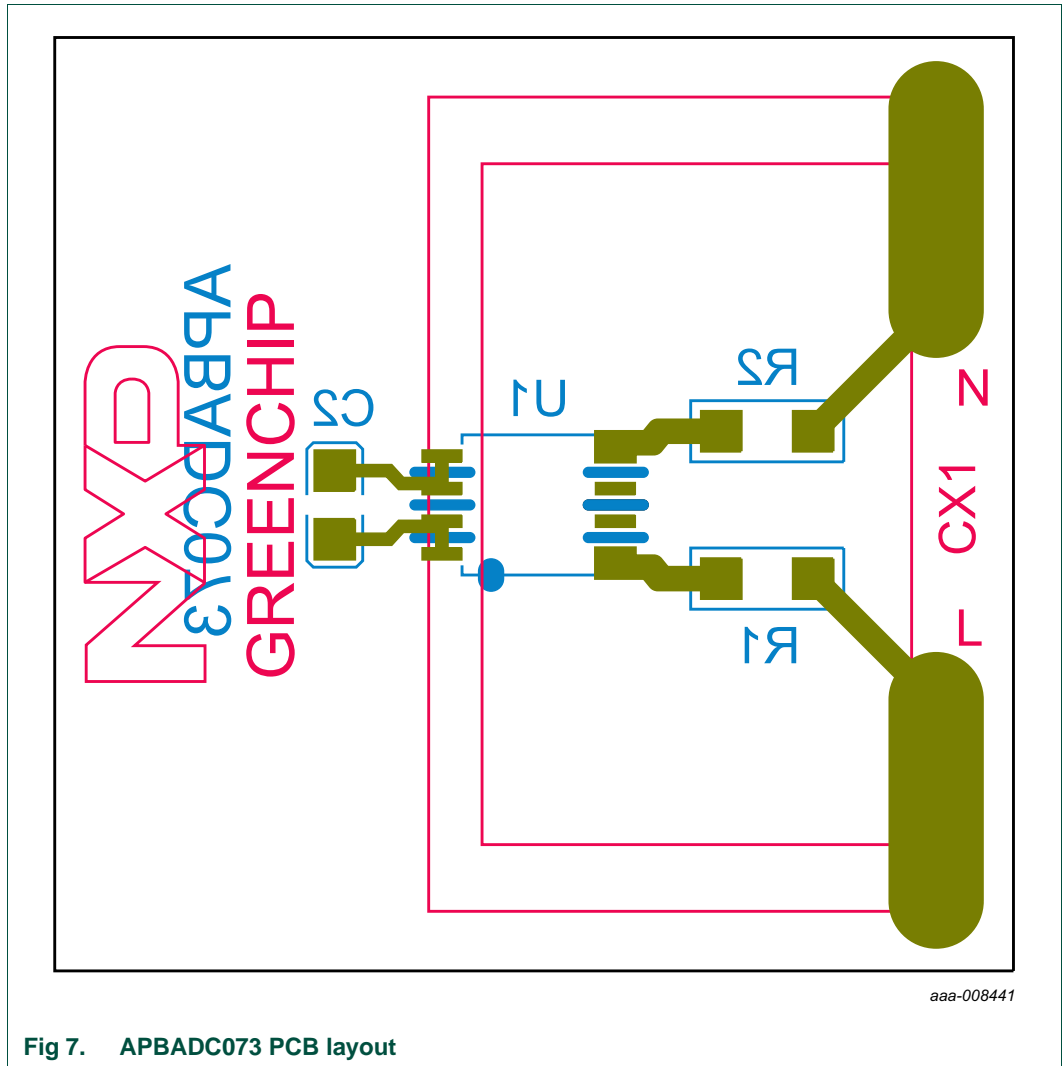

Fig 7. APBADC073 PCB layout

8. Bill Of Material (BOM)

Table 6. Bill of materials APBADC073 demo board

Reference	Description and values	Part number	Manufacturer
R1	resistor; 200 kΩ; 5 %; SMD; 1206	-	-
R2	resistor; 200 kΩ; 5 %	-	-
CX1	X2 capacitor; 1 μF; 275 V; Axial; MKP	-	-
C2	capacitor; 10 nF; 50 V; SMD; 0805; MLCC; X7R	-	-
U1	IC; TEA1708T	SO8	NXP Semiconductors

9. Legal information

9.1 Definitions

Draft — The document is a draft version only. The content is still under internal review and subject to formal approval, which may result in modifications or additions. NXP Semiconductors does not give any representations or warranties as to the accuracy or completeness of information included herein and shall have no liability for the consequences of use of such information.

9.2 Disclaimers

Limited warranty and liability — Information in this document is believed to be accurate and reliable. However, NXP Semiconductors does not give any representations or warranties, expressed or implied, as to the accuracy or completeness of such information and shall have no liability for the consequences of use of such information. NXP Semiconductors takes no responsibility for the content in this document if provided by an information source outside of NXP Semiconductors.

In no event shall NXP Semiconductors be liable for any indirect, incidental, punitive, special or consequential damages (including - without limitation - lost profits, lost savings, business interruption, costs related to the removal or replacement of any products or rework charges) whether or not such damages are based on tort (including negligence), warranty, breach of contract or any other legal theory.

Notwithstanding any damages that customer might incur for any reason whatsoever, NXP Semiconductors' aggregate and cumulative liability towards customer for the products described herein shall be limited in accordance with the *Terms and conditions of commercial sale* of NXP Semiconductors.

Right to make changes — NXP Semiconductors reserves the right to make changes to information published in this document, including without limitation specifications and product descriptions, at any time and without notice. This document supersedes and replaces all information supplied prior to the publication hereof.

Suitability for use — NXP Semiconductors products are not designed, authorized or warranted to be suitable for use in life support, life-critical or safety-critical systems or equipment, nor in applications where failure or malfunction of an NXP Semiconductors product can reasonably be expected to result in personal injury, death or severe property or environmental damage. NXP Semiconductors and its suppliers accept no liability for inclusion and/or use of NXP Semiconductors products in such equipment or applications and therefore such inclusion and/or use is at the customer's own risk.

Applications — Applications that are described herein for any of these products are for illustrative purposes only. NXP Semiconductors makes no representation or warranty that such applications will be suitable for the specified use without further testing or modification.

Customers are responsible for the design and operation of their applications and products using NXP Semiconductors products, and NXP Semiconductors accepts no liability for any assistance with applications or customer product design. It is customer's sole responsibility to determine whether the NXP Semiconductors product is suitable and fit for the customer's applications and products planned, as well as for the planned application and use of customer's third party customer(s). Customers should provide appropriate design and operating safeguards to minimize the risks associated with their applications and products.

NXP Semiconductors does not accept any liability related to any default, damage, costs or problem which is based on any weakness or default in the customer's applications or products, or the application or use by customer's third party customer(s). Customer is responsible for doing all necessary testing for the customer's applications and products using NXP Semiconductors products in order to avoid a default of the applications and the products or of the application or use by customer's third party customer(s). NXP does not accept any liability in this respect.

Export control — This document as well as the item(s) described herein may be subject to export control regulations. Export might require a prior authorization from competent authorities.

Evaluation products — This product is provided on an "as is" and "with all faults" basis for evaluation purposes only. NXP Semiconductors, its affiliates and their suppliers expressly disclaim all warranties, whether express, implied or statutory, including but not limited to the implied warranties of non-infringement, merchantability and fitness for a particular purpose. The entire risk as to the quality, or arising out of the use or performance, of this product remains with customer.

In no event shall NXP Semiconductors, its affiliates or their suppliers be liable to customer for any special, indirect, consequential, punitive or incidental damages (including without limitation damages for loss of business, business interruption, loss of use, loss of data or information, and the like) arising out of the use of or inability to use the product, whether or not based on tort (including negligence), strict liability, breach of contract, breach of warranty or any other theory, even if advised of the possibility of such damages.

Notwithstanding any damages that customer might incur for any reason whatsoever (including without limitation, all damages referenced above and all direct or general damages), the entire liability of NXP Semiconductors, its affiliates and their suppliers and customer's exclusive remedy for all of the foregoing shall be limited to actual damages incurred by customer based on reasonable reliance up to the greater of the amount actually paid by customer for the product or five dollars (US\$5.00). The foregoing limitations, exclusions and disclaimers shall apply to the maximum extent permitted by applicable law, even if any remedy fails of its essential purpose.

Safety of high-voltage evaluation products — The non-insulated high voltages that are present when operating this product, constitute a risk of electric shock, personal injury, death and/or ignition of fire. This product is intended for evaluation purposes only. It shall be operated in a designated test area by personnel that is qualified according to local requirements and labor laws to work with non-insulated mains voltages and high-voltage circuits.

The product does not comply with IEC 60950 based national or regional safety standards. NXP Semiconductors does not accept any liability for damages incurred due to inappropriate use of this product or related to non-insulated high voltages. Any use of this product is at customer's own risk and liability. The customer shall fully indemnify and hold harmless NXP Semiconductors from any liability, damages and claims resulting from the use of the product.

Translations — A non-English (translated) version of a document is for reference only. The English version shall prevail in case of any discrepancy between the translated and English versions.

9.3 Trademarks

Notice: All referenced brands, product names, service names and trademarks are the property of their respective owners.

GreenChip — is a trademark of NXP B.V.