



TEA1833LTS

GreenChip SMPS control IC

Rev. 1.1 — 8 February 2023

Product data sheet

1 General description

The TEA1833LTS is a low-cost switched-mode power supply (SMPS) controller IC intended for flyback topologies. The TEA1833LTS operates in peak current and frequency control mode. Frequency jitter has been implemented to reduce electromagnetic interference (EMI). Slope compensation is integrated for continuous conduction mode (CCM) operation.

The TEA1833LTS IC features overpower protection (OPP). The controller accepts an overpower situation up to 200 % for a limited time.

Mains undervoltage protection (brownin/brownout), output overvoltage protection (OVP), and overtemperature protection (OTP) can be implemented using a minimal number of external components.

At low-power levels, the primary peak current is set to 22 % of the maximum peak current. The switching frequency is reduced to limit the switching losses. The combination of fixed frequency operation at high output power and frequency reduction at low output power provides high efficiency over the total load range.

The TEA1833LTS makes the design of low-cost, highly efficient, and reliable supplies easier by requiring a minimum number of external components. The device is especially suited for medium power applications.



2 Features and benefits

- SMPS controller IC enabling low-cost applications
- Large input voltage range (10.5 V to 36 V)
- Integrated overvoltage protection (OVP) on the VCC pin
- Accurate overvoltage protection (OVP) via the ISENSE pin
- Dedicated burst mode, allowing a low VCC capacitor value
- Very low supply current during start-up and restart (11 μ A typical)
- Low supply current during normal operation (0.58 mA typical without load)
- Adaptive internal overpower timeout
- Overpower protection including high/low line compensation
- Fixed switching frequency with frequency jitter to reduce EMI
- Frequency reduction with fixed minimum peak current to maintain high efficiency at low output power levels
- Peak power operation up to 200 % by frequency increase and peak current increase
- Slope compensation for CCM operation
- Limitation of switching frequency at high mains to reduce the maximum drain voltage
- Integrated soft-start
- Drive capability 300 mA source, 750 mA sink
- Maximum duty cycle set at 90 %
- Mains undervoltage protection (brownin/brownout)
- Output short-circuit protection (OSCP), avoiding transformer saturation
- External overtemperature protection (OTP)
- IC overtemperature protection
- Maximum duty cycle protection and brownin/brownout protection cause a restart, all other protections are latched

3 Applications

- All applications that require an efficient and cost-effective power supply solution. The TEA1833LTS is especially suited for medium power applications.

4 Ordering information

Table 1. Ordering information

Type number	Package		Version
	Name	Description	
TEA1833LTS/1	TSOP6	plastic surface-mounted package; 6 leads	SOT457

5 Marking

Table 2. Marking

Type number	Marking code
TEA1833LTS/1	EA1833L

6 Block diagram

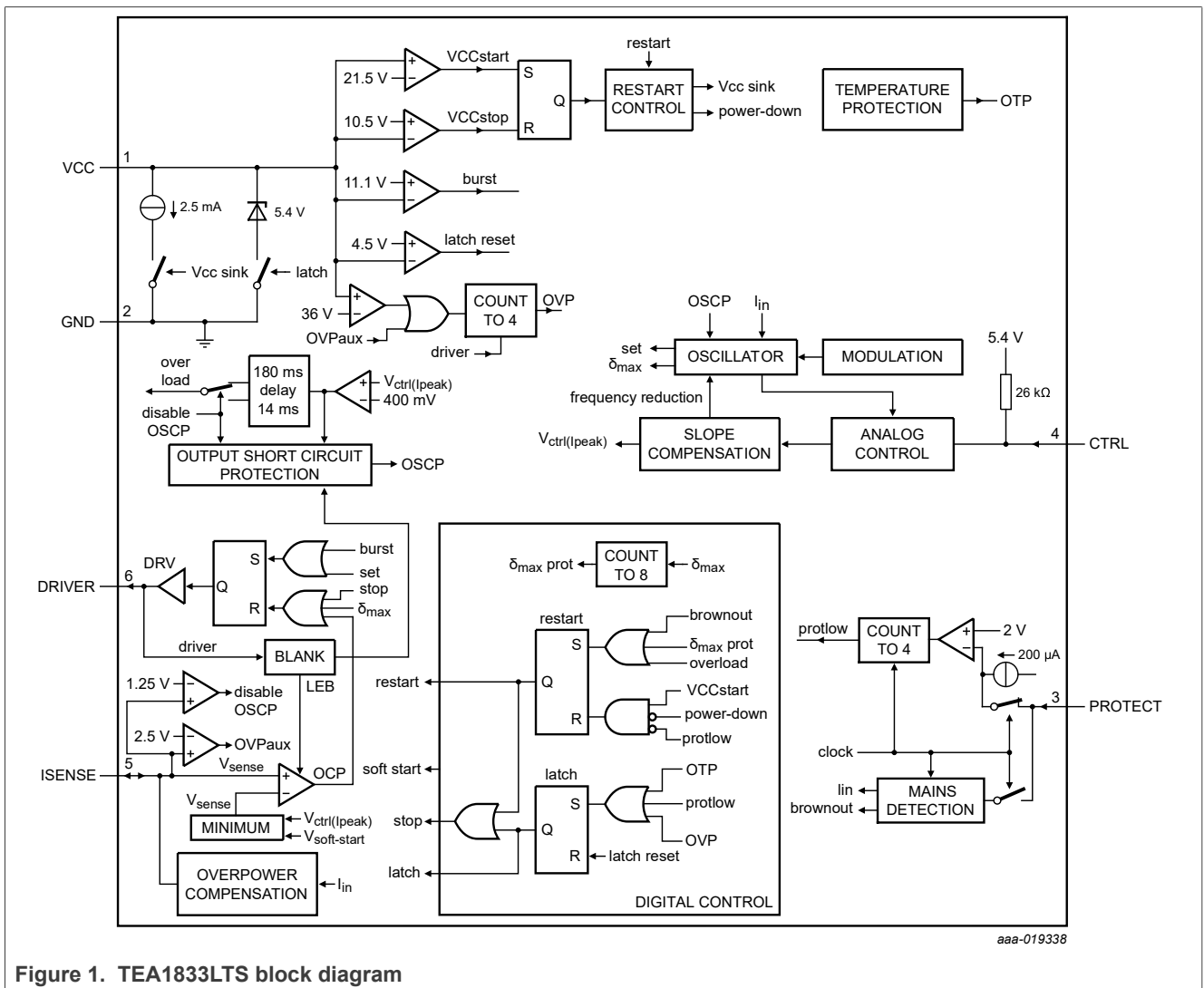
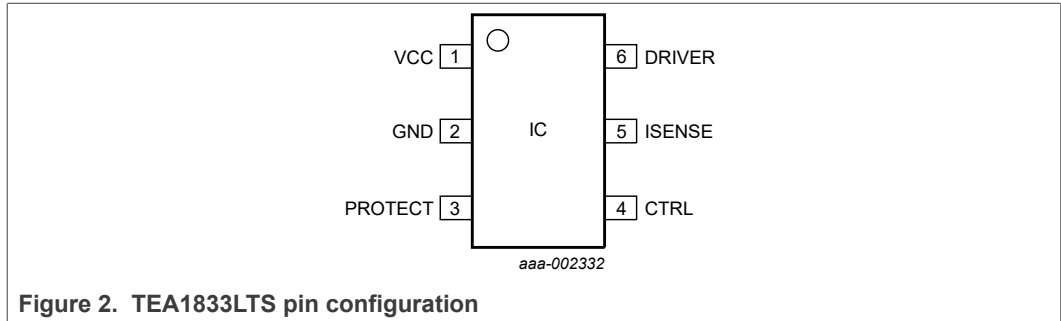

Figure 1. TEA1833LTS block diagram

7 Pinning information

7.1 Pinning



7.2 Pin description

Table 3. Pin description

Symbol	Pin	Description
VCC	1	supply voltage
GND	2	ground
PROTECT	3	protection and mains detect input
CTRL	4	control input
ISENSE	5	current sense and accurate OVP input
DRIVER	6	gate driver output

8 Functional description

8.1 General control

The TEA1833LTS contains a controller for a flyback circuit. [Figure 3](#) shows a typical configuration.

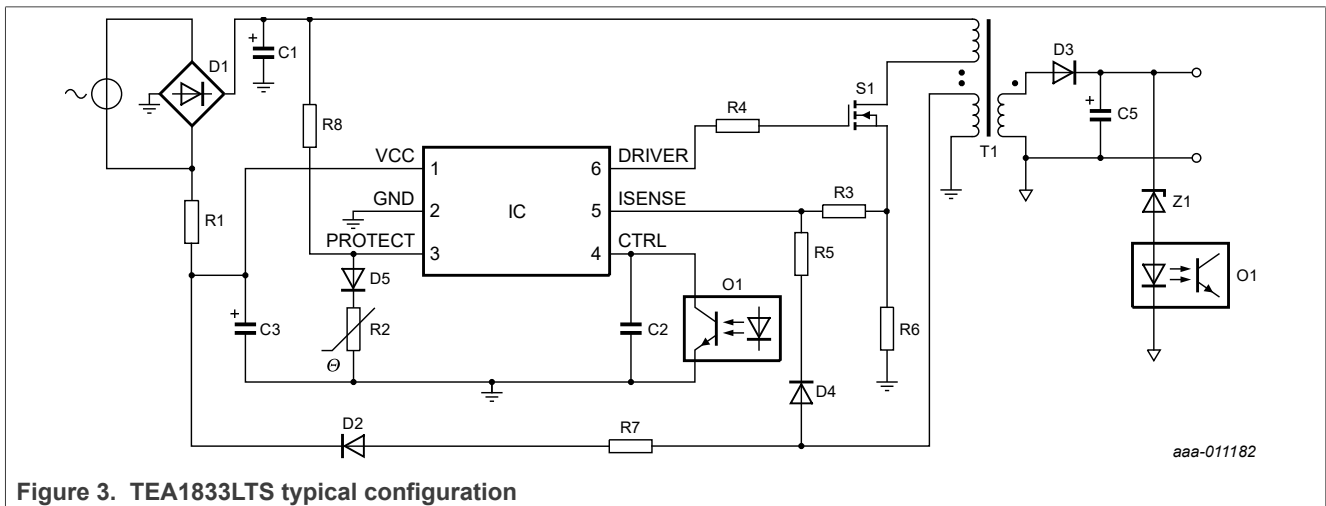

Figure 3. TEA1833LTS typical configuration

8.2 Start-up and undervoltage lockout (UVLO)

Initially, the capacitor on the VCC pin, C3, is charged from the high-voltage mains via resistor R1.

As long as the voltage on the VCC pin is below V_{startup} , the IC current consumption is low (11 μA typical). When the voltage on the VCC pin reaches V_{startup} , the IC first checks the PROTECT pin. Only when the current exceeds the brownin level ($I_{\text{mains}(bi)}$) during mains detect and the voltage surpasses $V_{\text{det(PROTECT)}}$ during external OTP measurement, the IC starts switching. An internal soft-start time of 3.5 ms allows the ISENSE peak voltage to increase gradually to prevent audible noise. In a typical application, the auxiliary winding of the transformer takes over the supply voltage.

If a protection is triggered, the controller stops switching. Depending on the protection triggered, it either causes a restart or latches the converter to an off-state.

The brownin/brownout, maximum duty cycle protections cause a safe restart. OPP, UVLO, the internal and external OVP, and the internal and external OTP latch the converter to an off-state.

A restart protection disables the switching of the IC. The supply voltage of the IC drops to the UVLO level. When the UVLO level is reached, the IC switches to power-down mode, where it consumes a low supply current (11 μA typical). The VCC capacitor is recharged via R1 until the VCC start-up level is reached. The IC starts switching again.

When a latched protection is triggered, the TEA1833LTS immediately enters the power-down mode. The VCC pin is clamped to a voltage just above the latch protection reset voltage ($V_{\text{rst(latch)}} + 1 \text{ V}$).

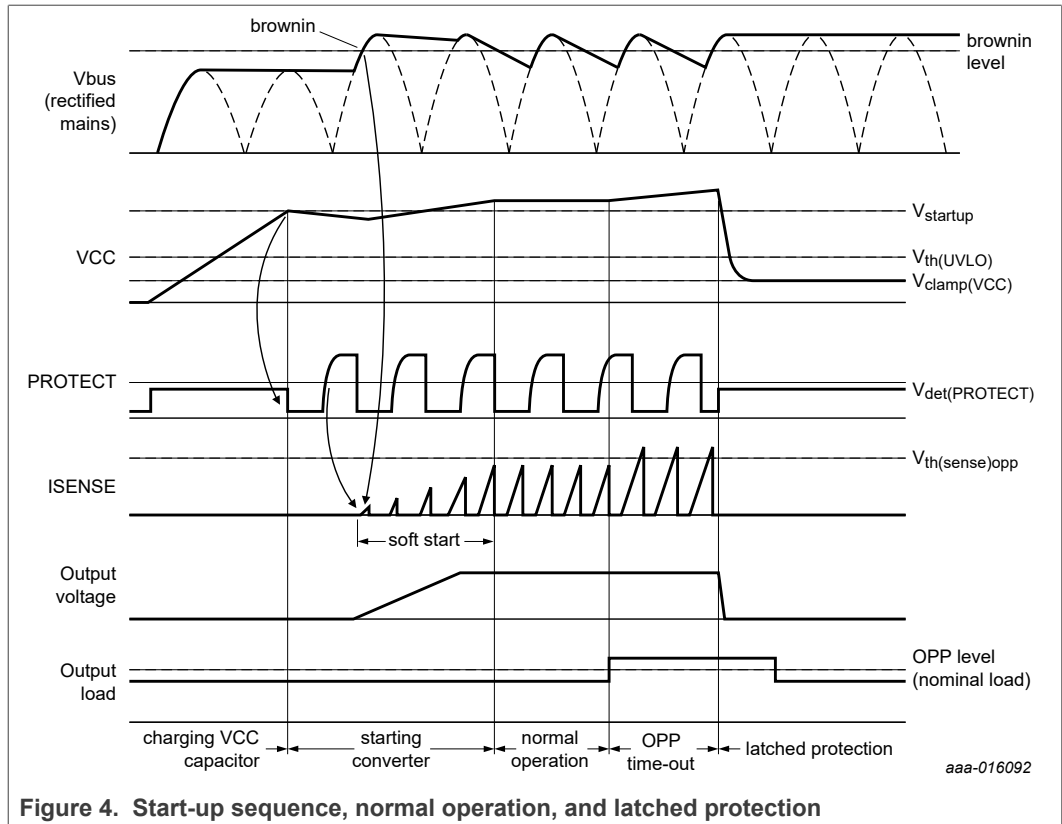

Figure 4. Start-up sequence, normal operation, and latched protection

When the voltage on pin VCC drops to below the $V_{th(UVLO)}$ level during normal operation, the controller stops switching. The TEA1833LTS activates the latched protection and enters the power-down mode. This mechanism avoids that, during a short circuit, a restart occurs when the supply voltage reaches $V_{th(UVLO)}$ before the OPP timeout is reached (see [Section 8.7](#)).

8.3 Supply management

All internal reference voltages are derived from a temperature-compensated on-chip band gap circuit. Internal reference currents are derived from a trimmed and temperature-compensated current reference circuit.

8.4 External overtemperature protection and mains detect input (pin PROTECT)

The PROTECT input combines the functions of the mains voltage detection (brownin/ brownout) and the external overtemperature protection (OTP). An internal clock separates the period of measuring the mains voltage and the period of detecting external overtemperature protection (OTP). In a typical application, the PROTECT pin is connected to the mains via a resistor. It is connected to ground via a negative temperature coefficient (NTC) thermistor and a diode.

When measuring the mains voltage, the PROTECT pin is regulated to 0.25 V to prevent that the external diode conducts current. The current into the PROTECT pin is measured and stored. When the measured current exceeds the brownin level, the system is allowed to start switching. If the mains voltage is continuously below the brownout level for at least 32 ms, a brownout is detected. The system immediately stops switching and

performs a restart. The VCC capacitor is discharged to the UVLO level and then charged to $V_{startup}$ once before switching recommences (See [Figure 5](#)).

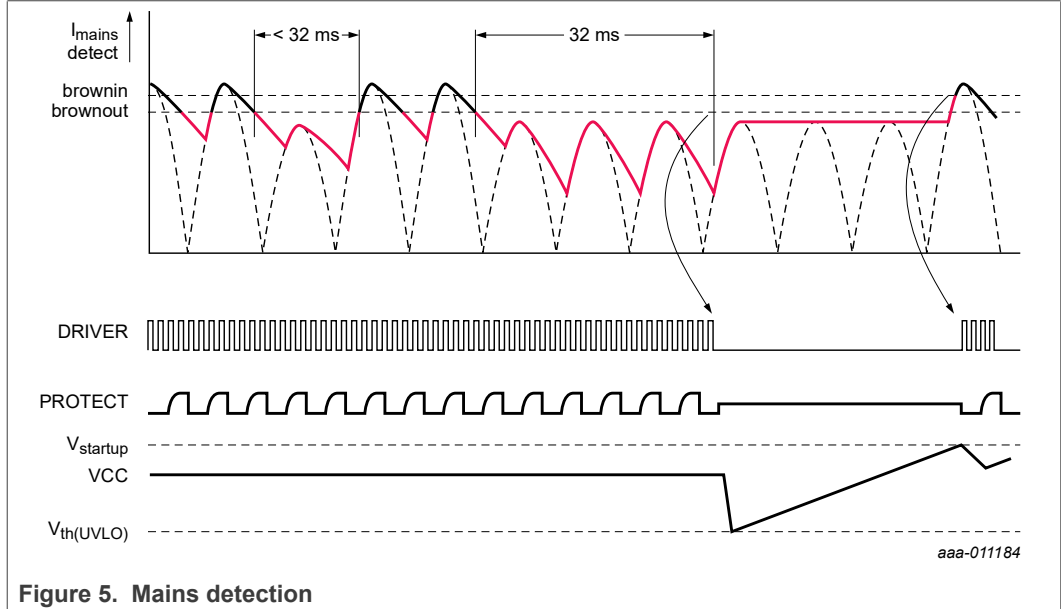

Figure 5. Mains detection

When detecting the external temperature, a current of 200 μA (typical) out of the PROTECT pin flows through the external capacitor and the NTC thermistor. If the PROTECT voltage at the end of the measuring period is below $V_{det}(\text{PROTECT})$ for four consecutive measuring cycles, the IC detects overtemperature. It activates a latched protection.

The offset due to the current from the mains is canceled internally by remembering the sinking current I_{in} when measuring the mains voltage (see [Figure 6](#)). The stored current is also used as the input of high/low line compensation and for the maximum switching frequency limitation.

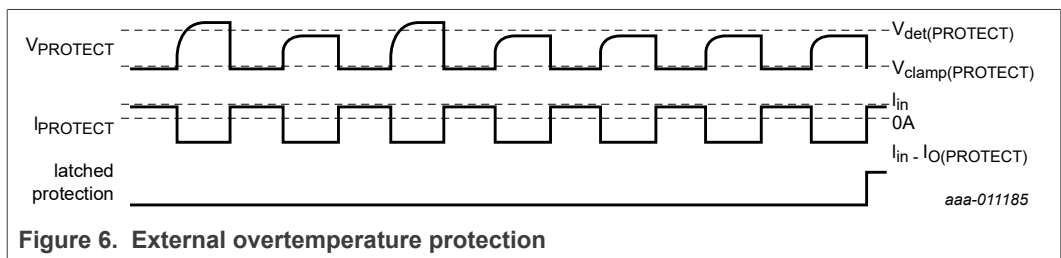

Figure 6. External overtemperature protection

An internal clamp of 4.1 V (typical) protects this pin from excessive voltages.

8.5 Duty cycle control (pin CTRL)

Pin CTRL regulates the output power of the converter. This pin is connected to an internal voltage source of 5.4 V via an internal resistor (typical resistance: 26 k Ω).

The CTRL pin voltage sets the peak current which is measured using the ISENSE pin (see [Section 8.8](#)). At low output power, the switching frequency is reduced (see [Section 8.12](#)). The maximum duty cycle is limited to 90 % (typical).

After eight consecutive converter strokes at maximum duty cycle, the restart protection is activated. In a restart, the VCC capacitor is quickly discharged to the $V_{th(UVLO)}$ level and recharged to the start-up level from the high-voltage mains, before switching recommences.

8.6 Slope compensation (pin CTRL)

A slope compensation circuit is integrated for CCM. The slope compensation ensures stable operation for duty cycles exceeding 50 %.

8.7 Overpower timer

A temporary overload situation is allowed. If V_{sense} (see Figure 1) set by pin CTRL exceeds 400 mV, an internal timer is started. If the overload situation continues to exist for more than 160 ms (typical), an overpower protection (OPP) is triggered (see Figure 7).

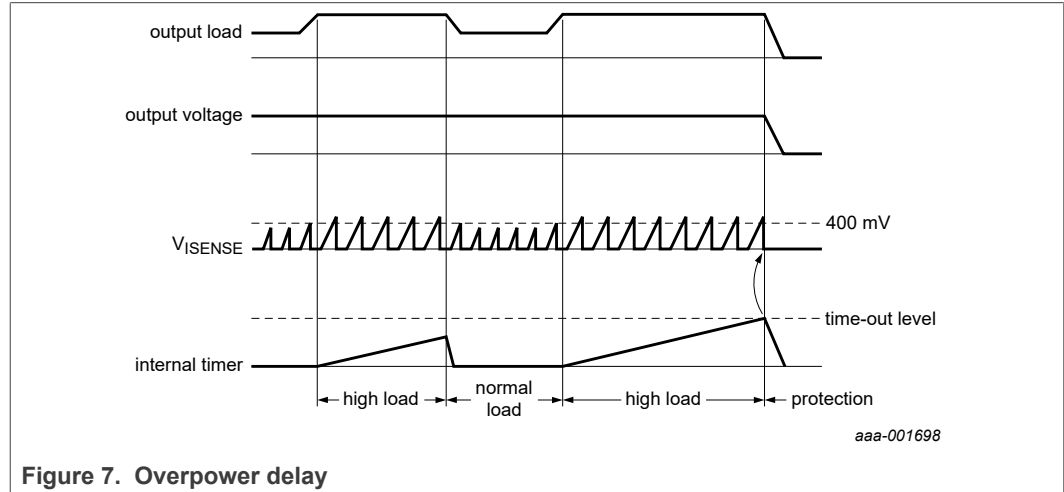

Figure 7. Overpower delay

The TEA1833LTS activates the latched protection and enters the power-down mode. To prevent a restart when, during a short circuit of the output VCC drops to below $V_{th(UVLO)}$ earlier than the OPP timeout is reached, this protection is also latched (see Section 8.2).

8.8 Current mode control (pin ISENSE)

Current mode control is used because it ensures a good line regulation.

Pin ISENSE senses the primary current across external resistor R6 and compares it with an internal control voltage. The internal control voltage is proportional to the CTRL pin voltage (see Figure 8).

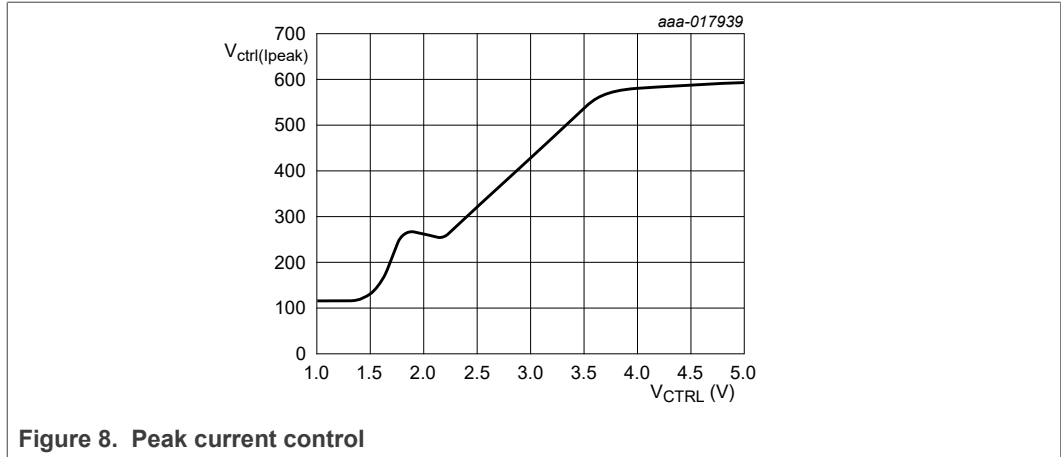

Figure 8. Peak current control

Leading-edge blanking prevents false triggering due to capacitive discharge when switching on the external power switch (see Figure 9).

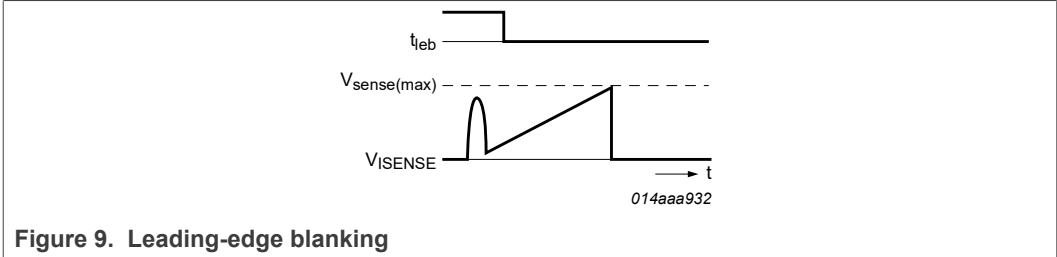

Figure 9. Leading-edge blanking

8.9 Overvoltage protection (pin ISENSE)

Accurate overvoltage protection can be realized at the ISENSE pin by sensing the auxiliary voltage. During the primary stroke, diode D4 (see Figure 3) is blocked so that the converter still works under current mode control. During the secondary stroke, the ISENSE voltage represents the output voltage via the resistor divider R5 and R3 (see Figure 3). The ISENSE voltage is sampled 2 μs after the gate signal drops to avoid the ringing of the transformer. If the sampled voltage exceeds V_{ovp(ISENSE)} for four consecutive switching cycles, the IC triggers the latched protection.

8.10 Overvoltage protection (pin VCC)

An overvoltage protection (OVP) circuit is connected to the VCC pin. When the V_{CC} exceeds V_{th(OVP)} (36 V typical) for four consecutive switching cycles, the IC triggers the latched protection. When V_{CC} drops to below V_{th(OVP)} before count = 4 is reached, the counter is reset to zero.

8.11 Output short-circuit protection (OSCP)

A flyback controller operating in CCM at a fixed frequency turns on the primary MOSFET after a predefined period (see Figure 10). The minimum on-time equals the blanking time. If after the blanking time the measured peak current (V_{ISENSE}) is higher than the I_{peak} regulation level, the driver is switched off.

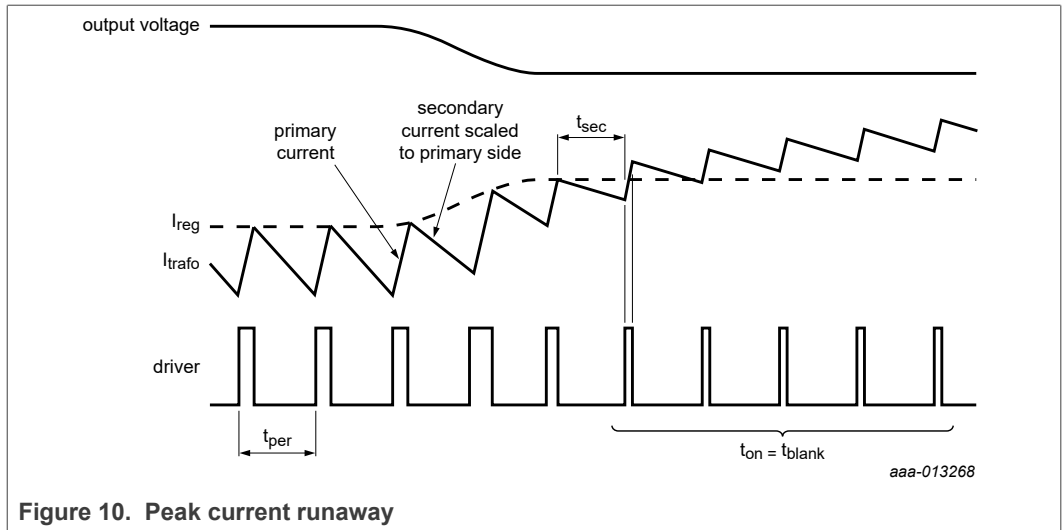

The output voltage can drop, for instance, because a load is too high or a short-circuit event occurs. If the output voltage drops, the decrease of the transformer current during the secondary stroke time (t_{sec}) becomes less. As a result, the next cycle starts at a higher peak current.

Also, at the next cycle, the minimum on-time equals the blanking time. During this blanking time, the peak current can increase to above the targeted regulation level. If the transformer current does not decrease sufficiently during the secondary stroke, the peak current can continuously increase to such a level that the transformer saturates (see [Figure 10](#)).

To avoid this continuous peak current increase, also called runaway, the IC features a special protection (see [Figure 11](#)).

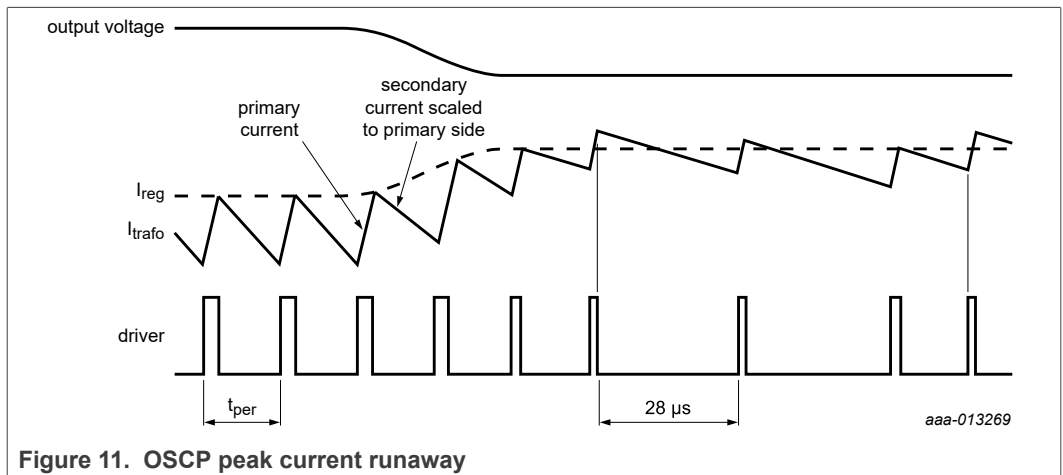

If the system detects that the peak current already exceeds the targeted level after $1 \mu s$, the next switching period time is extended from $7.7 \mu s$ ($f_{sw} = 130 \text{ kHz}$) to $28 \mu s$ ($f_{sw} = 36 \text{ kHz}$). The time of the secondary stroke is then sufficient to decrease the transformer current to below the targeted peak current again.

To avoid activation at low loads, the OSCP is only enabled when the overpower timer is active. Additionally, to avoid activation during peak power, V_{out} must be below half the OVP level.

The V_{out} level is measured on the ISENSE pin in a similar way that the overvoltage protection is measured.

To limit the input power during a short circuit or an overload event, the OPP time is reduced to 50 % when OSCP is enabled.

8.12 Peak power, high-power medium power, and low-power operation

During high-power operation, with the converter running at a 65 kHz (typical) fixed frequency, the power is controlled by varying the peak current.

A peak power mode is implemented to supply a short overload situation. In peak power mode, both frequency and peak current are increased.

In medium power operation, lowering the switching frequency to 25 kHz reduces the switching losses.

In low-power operation, lowering of the switching frequency to below 25 kHz further reduces switching losses. The switching frequency of the converter is reduced while the peak current is set to 22 % of the maximum peak current (see [Figure 8](#) and [Figure 12](#)).

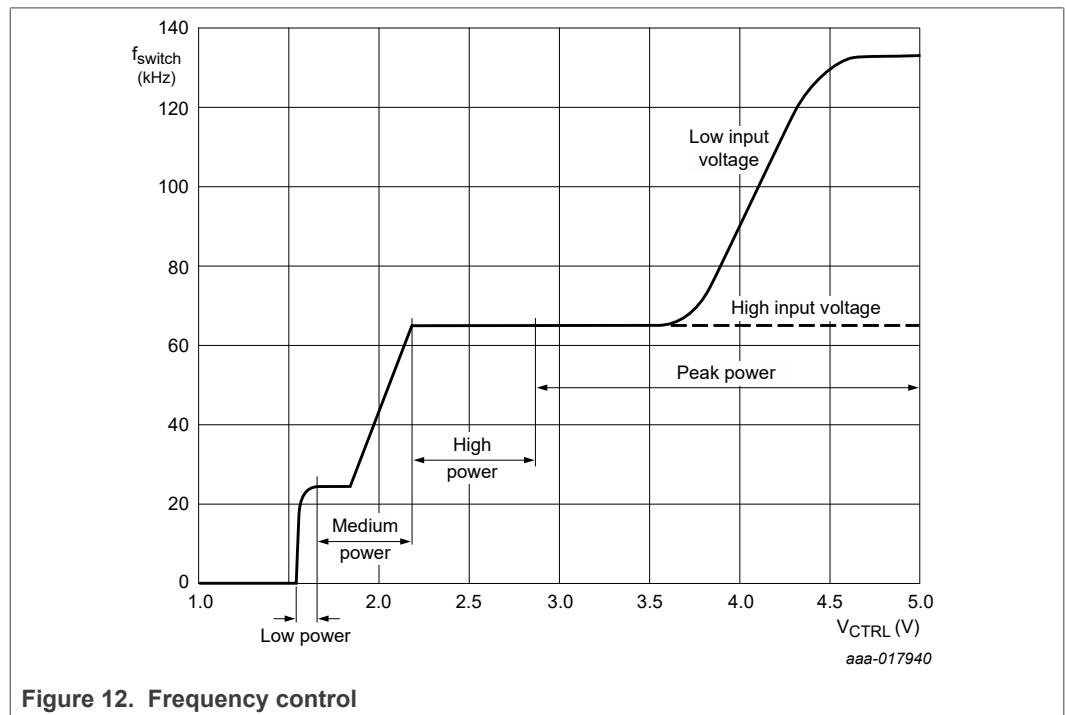
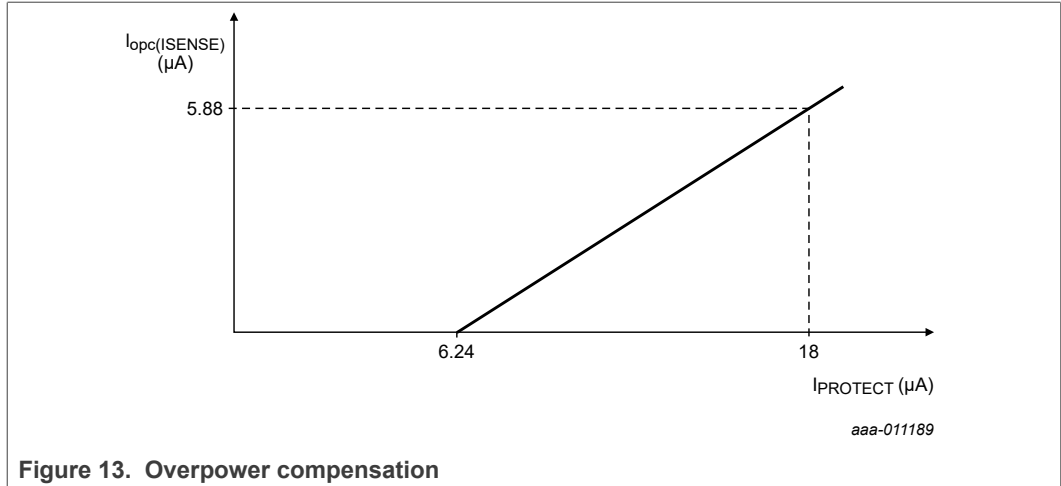

Figure 12. Frequency control

8.13 Overpower or high/low line compensation

The overpower compensation function can be used to realize a maximum output power which is nearly constant over the full input mains. The overpower compensation circuit measures the mains detect input current on the PROTECT pin and outputs a proportionally dependent current on the ISENSE pin. The DC voltage across resistor R3 (see [Figure 3](#)) limits the maximum peak current on the current sense resistor (see [Figure 13](#)).

At low output power levels, the overpower compensation circuit is switched off.



8.14 Burst mode

If the CTRL voltage (V_{CTRL}) < 1.45 V, the system is not switching. It waits until the V_{CTRL} exceeds this minimum level before starting the next cycle. During this period, the TEA1833LTS discharges the primary VCC capacitor. If the voltage on the VCC pin then drops to below the burst threshold level ($V_{th(burst)}$), the system asserts two DRIVER pulses to recharge the VCC capacitor. The assertion avoids that the voltage on the VCC pin drops to below the UVLO level during a large off-time.

Worst off-time occurs when there is a load transient from peak load to no-load. The output voltage shows an overshoot and stops switching until the output voltage drops to below the regulation level while there is no-load at the output.

For minimum no-load input power, the chosen value of the external capacitor at the VCC pin must be high enough to prevent that the voltage on the VCC pin drops below the burst threshold level at continuous no-load operation. The burst mode is only intended to assist at load changes until the output voltage drops to below the regulation level while there is no-load at the output.

8.15 Limitation of the maximum switching frequency

At high mains, the maximum switching frequency is limited (see Figure 14). The 130 kHz switching frequency is required at low mains only. At high mains, the high switching frequency during peak power causes an unnecessary high voltage on the drain of the MOSFET, because the high switching frequency increases the clamp voltage.

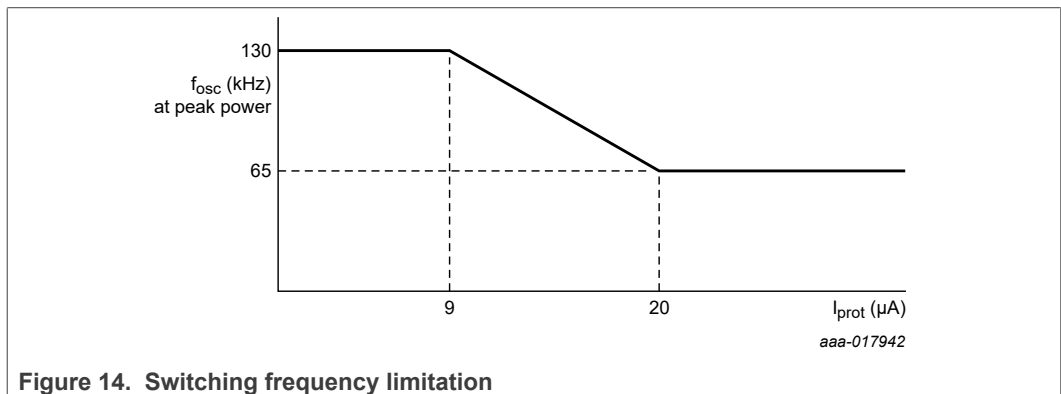

8.16 Driver (pin DRIVER)

The driver circuit to the gate of the power MOSFET has a current sourcing capability of typically 300 mA and a current sink capability of typically 750 mA. These capabilities enable a fast turn-on and turn-off of the power MOSFET for efficient operation.

8.17 Overtemperature protection (OTP)

If the junction temperature exceeds the thermal shutdown limit, integrated overtemperature protection ensures that the IC stops switching.

OTP is a latched protection. It can be reset by removing the voltage on pin VCC.

9 Limiting values

Table 4. Limiting values

In accordance with the Absolute Maximum Rating System (IEC 60134).

Symbol	Parameter	Conditions	Min	Max	Unit
Voltages					
V_{CC}	supply voltage		-0.4	+40	V
$V_{PROTECT}$	voltage on pin PROTECT	current limited	-0.4	+5	V
V_{CTRL}	voltage on pin CTRL		-0.4	+5.5	V
V_{ISENSE}	voltage on pin ISENSE	current limited to 2 mA	-0.7	+5	V
Currents					
I_{VCC}	current on pin VCC	$\delta < 10\%$	-	0.4	A
$I_{I(PROTECT)}$	input current on pin PROTECT		-1	+1	mA
I_{CTRL}	current on pin CTRL		-3	0	mA
I_{ISENSE}	current on pin ISENSE		-10	+0.5	mA
I_{DRIVER}	current on pin DRIVER	$\delta < 10\%$	-0.4	+1	A
General					
P_{tot}	total power dissipation	$T_{amb} < 75\text{ °C}$	-	0.29	W
T_{stg}	storage temperature		-55	+150	°C
T_j	junction temperature		-40	+150	°C
ESD					
V_{ESD}	electrostatic discharge voltage	human body model (HBM); JEDEC class 2; all pins	-2500	+2500	V
		charged device model (CDM); JEDEC class 3; all pins	-750	+750	V

10 Thermal characteristics

Table 5. Thermal characteristics

Symbol	Parameter	Conditions	Typ	Unit
$R_{th(j-a)}$	thermal resistance from junction to ambient	in free air; single-layer JEDEC test board	259	K/W
$R_{th(j-c)}$	thermal resistance from junction to case	in free air; JEDEC test board	152	K/W

11 Characteristics

Table 6. Characteristics

$T_{amb} = 25\text{ }^{\circ}\text{C}$; $V_{CC} = 20\text{ V}$; all voltages are measured with respect to ground (pin 2); currents are positive when flowing into the IC; unless otherwise specified.

Symbol	Parameter	Conditions	Min	Typ	Max	Unit
Supply voltage management (pin VCC)						
$V_{startup}$	start-up voltage		20.2	22	24	V
$V_{th(UVLO)}$	undervoltage lockout threshold voltage		9.4	10.5	11.6	V
V_{hys}	hysteresis voltage	$V_{startup} - V_{th(UVLO)}$	8.5	11.5	14.5	V
$V_{th(burst)}$	burst mode threshold voltage		-	11.1	-	V
$\Delta V_{th(burst-UVLO)}$	burst mode to UVLO threshold voltage difference	$V_{th(burst)} > V_{th(UVLO)}$ ^[1]	0.5	0.6	0.7	V
$V_{rst(latch)}$	latched reset voltage		3.5	4.5	5.5	V
$V_{clamp(VCC)}$	clamp voltage on pin VCC	latched protection mode; $I_{CC} = 15\text{ }\mu\text{A}$	$V_{rst(latch)} + 1$	-	-	V
		latched protection mode; $I_{CC} = 500\text{ }\mu\text{A}$	-	-	$V_{rst(latch)} + 4$	V
$I_{CC(startup)}$	start-up supply current	$V_{CC} < V_{startup}$	9	11	16	μA
$I_{CC(oper)}$	operating supply current	no-load on pin DRIVER; $\delta = 2\text{ }%$; excluding optocurrent	-	0.58	-	mA
		no-load on pin DRIVER; $\delta = 25\text{ }%$; excluding optocurrent	-	0.62	-	mA
$I_{CC(restart)}$	restart supply current		1	2.5	-	mA
Protection input (pin PROTECT)						
$V_{det(PROTECT)}$	detection voltage on pin PROTECT	$I_{I(PROTECT)} = -200\text{ }\mu\text{A}$	1.95	2	2.05	V
$I_{O(PROTECT)}$	output current on pin PROTECT	$V_{PROTECT} = V_{det(PROTECT)}$	-212.5	-200	-187.5	μA
$V_{clamp(PROTECT)}$	clamp voltage on pin PROTECT	$I_{I(PROTECT)} = 6\text{ }\mu\text{A}$; mains detect period; $C_{max(PROTECT)} = 10\text{ pF}$	205	260	315	mV
		$I_{I(PROTECT)} \geq -200\text{ }\mu\text{A}$; OTP measurement period ^[2]	3.5	4.1	4.7	V
Mains detect (pin PROTECT)						
$I_{mains(bi)}$	mains brownin current		5.28	5.7	6.12	μA
$I_{mains(bo)}$	mains brownout current		4.63	5.0	5.37	μA

Table 6. Characteristics ...continued

$T_{amb} = 25\text{ °C}$; $V_{CC} = 20\text{ V}$; all voltages are measured with respect to ground (pin 2); currents are positive when flowing into the IC; unless otherwise specified.

Symbol	Parameter	Conditions	Min	Typ	Max	Unit
Peak current control (pin CTRL)						
V_{CTRL}	voltage on pin CTRL	for minimum flyback peak current	1.3	1.6	1.9	V
		for maximum flyback peak current	3.4	3.9	4.3	V
$R_{int(CTRL)}$	internal resistance on pin CTRL		20	26	32	k Ω
$I_{O(CTRL)}$	output current on pin CTRL	$V_{CTRL} = 1.4\text{ V}$	-183	-138	-93	μA
		$V_{CTRL} = 3.7\text{ V}$	-67.5	-50	-32.5	μA
Pulse width modulator						
f_{osc}	oscillator frequency	OSCP	30	38	46	kHz
		peak power	118	130	142	kHz
		high power	60.5	65	69.5	kHz
		medium power	21	26	31	kHz
f_{mod}	modulation frequency		195	260	325	Hz
Δf_{mod}	modulation frequency variation	high power	± 3	± 4	± 5	kHz
δ_{max}	maximum duty cycle		86	90	94	%
$N_{cy(sw)\delta_{max}}$	number of switching cycles with maximum duty cycle	to trigger maximum duty cycle protection	7	-	8	
V_{CTRL}	voltage on pin CTRL	for zero duty cycle	1.15	1.45	1.75	V
		for start of frequency reduction from medium to low power	1.4	1.6	1.8	V
		for end of frequency reduction from high to medium power mode	1.6	1.8	2.0	V
		for start of frequency reduction from high to medium power mode	1.9	2.15	2.40	V
		for start of frequency increase from high to peak power mode	3.55	3.8	4.05	V
		for maximum frequency (peak power mode); at low mains; $I_{prot} < 8.5\text{ }\mu\text{A}$	4.45	4.75	5.05	V
Overpower protection						
$t_{to(opp)}$	overpower protection time-out time		160	180	200	ms

Table 6. Characteristics ...continued

$T_{amb} = 25\text{ }^{\circ}\text{C}$; $V_{CC} = 20\text{ V}$; all voltages are measured with respect to ground (pin 2); currents are positive when flowing into the IC; unless otherwise specified.

Symbol	Parameter	Conditions	Min	Typ	Max	Unit
Current sense and overpower compensation (pin ISENSE)						
$V_{\text{sense(max)}}$	maximum sense voltage	$\Delta V/\Delta t = 0\text{ V/s}$	0.555	0.590	0.625	V
$t_{\text{PD(sense)}}$	sense propagation delay		130	155	180	ns
$V_{\text{th(sense)opp}}$	overpower protection sense threshold voltage		380	410	440	mV
$\Delta V_{\text{ISENSE}}/\Delta t$	slope compensation voltage on pin ISENSE	high-power mode	-	20	-	mV/ μs
t_{leb}	leading edge blanking time		275	325	375	ns
$I_{\text{opc(ISENSE)}}$	overpower compensation current on pin ISENSE	$I_{\text{PROTECT}} = 10\text{ }\mu\text{A}$; $V_{\text{ctrl(Ipeak)}} > 400\text{ mV}$	-1.5	-2	-2.5	μA
		$I_{\text{PROTECT}} = 18\text{ }\mu\text{A}$; $V_{\text{ctrl(Ipeak)}} > 400\text{ mV}$	-5.5	-6	-6.5	μA
Soft start (pin ISENSE)						
$t_{\text{start(soft)}}$	soft start time		2.7	3.5	4.2	ms
Driver (pin DRIVER)						
$I_{\text{source(DRIVER)}}$	source current on pin DRIVER	$V_{\text{DRIVER}} = 2\text{ V}$	-	-0.3	-0.25	A
$I_{\text{sink(DRIVER)}}$	sink current on pin DRIVER	$V_{\text{DRIVER}} = 2\text{ V}$	0.25	0.3	-	A
		$V_{\text{DRIVER}} = 10\text{ V}$	0.6	0.75	-	A
$V_{\text{O(DRIVER)max}}$	maximum output voltage on pin DRIVER		9	10.5	12	V
Overshoot protection (pins VCC and ISENSE)						
$V_{\text{ovp(VCC)}}$	overshoot protection voltage on pin VCC		34.8	36	37.2	V
$V_{\text{ovp(ISENSE)}}$	overshoot protection voltage on pin ISENSE		2.4	2.5	2.6	V
$t_{\text{blank(ovp)ISENSE}}$	overshoot protection blanking time on pin ISENSE		1.7	2.1	2.5	μs
$N_{\text{cy(ovp)}}$	number of overshoot protection cycles		4	4	4	
Output short circuit protection^[3]						
$V_{\text{dis(oscsp)ISENSE}}$	output short circuit protection disable voltage on pin ISENSE	OSCP is disabled when V_{ISENSE} exceeds $V_{\text{dis(oscsp)ISENSE}}$	1.2	1.25	1.3	V
$t_{\text{to(oscsp)}}$	output short circuit protection time-out time		11	14	17	ms

Table 6. Characteristics ...continued

$T_{amb} = 25\text{ °C}$; $V_{CC} = 20\text{ V}$; all voltages are measured with respect to ground (pin 2); currents are positive when flowing into the IC; unless otherwise specified.

Symbol	Parameter	Conditions	Min	Typ	Max	Unit
Temperature protection						
$T_{pl(IC)}$	IC protection level temperature		130	140	150	°C

[1] Guaranteed by design.

[2] The clamp voltage on the PROTECT pin is lowered when the IC is in power-down mode. (latched or restart protection).

[3] The output short-circuit protection (OSCP) is only enabled when the voltage level on the ISENSE pin during the secondary stroke is below $V_{dis(OSCP)ISENSE}$ level (half the $V_{OVP(ISENSE)}$ level). When enabled, the OSCP becomes active when the V_{sense} level exceeds $V_{th(sense)opp}$ and the V_{sense} level is reached within 1 μs (cycle-by-cycle). The switching period is then stretched to 28 μs (36 kHz, f_{osc} OSCP).

12 Application information

A power supply with the TEA1833LTS is a flyback converter which operates in both discontinuous conduction mode (DCM) and continuous conduction mode (CCM). Which mode depends on the input voltage and output power.

Resistor R1 charges the small buffer capacitor C3 at start-up. The auxiliary winding takes over during normal operation.

The driver pin switches the MOSFET. Resistor R4 is added to protect the driver against switching spikes due to parasitics (inductance and capacitance of tracks, MOSFET, and transformer).

Resistor R6 converts the MOSFET current to a voltage. It is measured on the ISENSE pin. The R6 value determines the maximum primary peak current through the MOSFET.

The measured peak current is compensated for the mains input voltage using a current through resistor R3 that is proportional to the bus voltage of capacitor C1. During the secondary stroke, the auxiliary voltage is measured using diode D4 and resistors R5, R3, and R6. The measured value can be used for an overvoltage protection for the output voltage.

Place capacitor C2 close to the CTRL pin to suppress noise.

The PROTECT pin cycles between mains voltage detect and external overtemperature measurement. During mains voltage detection, the current through resistor R8 is measured. This current relates to the voltage on capacitor C1 and the input voltage. The current is used to realize brownin, brownout, and input voltage compensation for the overpower protection.

During overtemperature protection, a current is sourced from the pin. The voltage over diode D5 and NTC resistor R2 is measured. A fixed comparator level detects when the NTC value drops too much.

To avoid pickup of disturbance, place both resistor R8 and diode D5/resistor R2 as close as possible to the pin.

13 Package outline

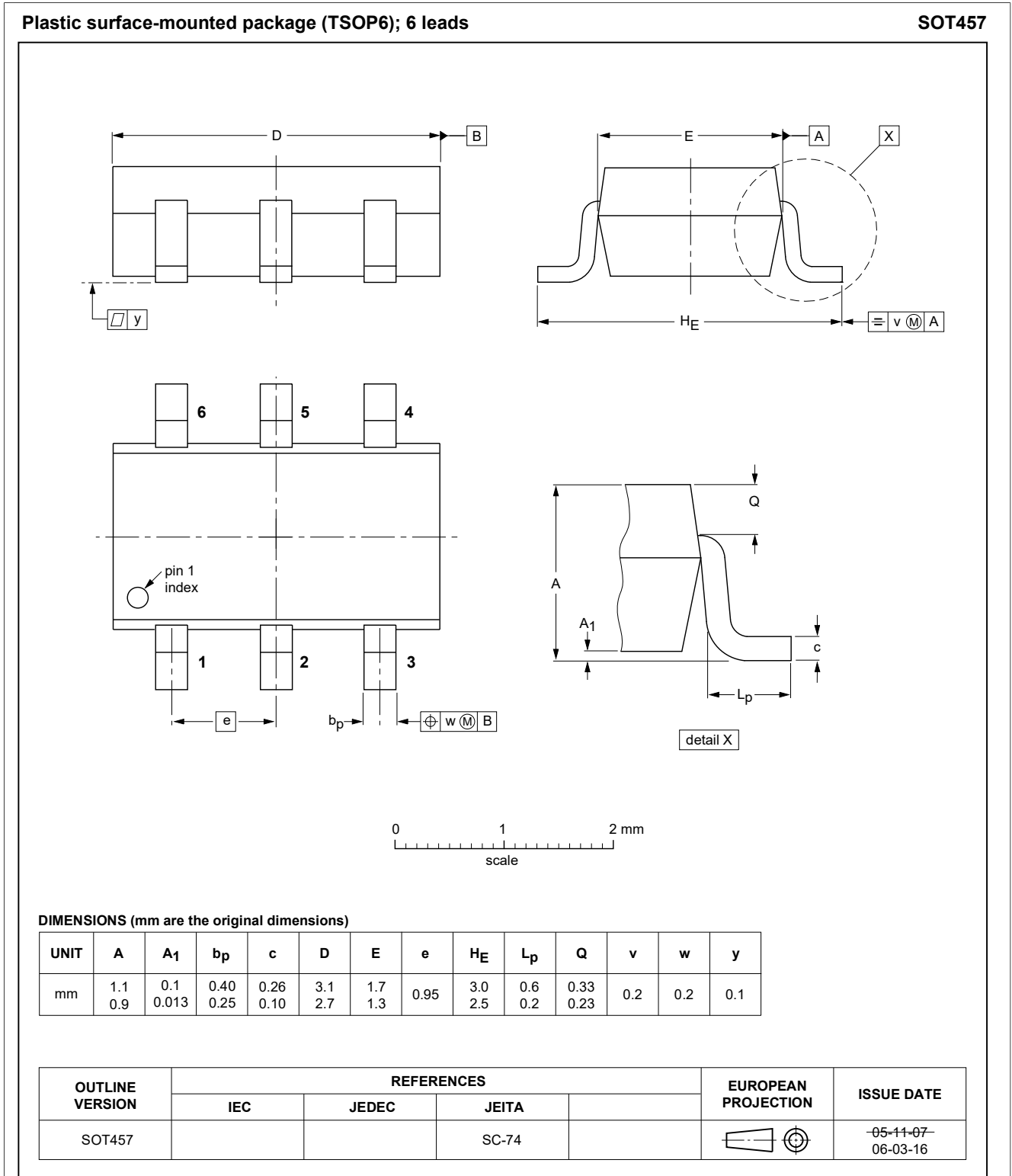

Figure 16. Package outline SOT457 (TSOP6)

14 Revision history

Table 7. Revision history

Document ID	Release date	Data sheet status	Change notice	Supersedes
TEA1833LTS v.1.1	20230208	Product data sheet	-	TEA1833LTS v.1
Modifications:	<ul style="list-style-type: none">• Section 5 "Marking" has been added to this document.• The document template has been updated.			
TEA1833LTS v.1	20170622	Product data sheet	-	-

15 Legal information

15.1 Data sheet status

Document status ^{[1][2]}	Product status ^[3]	Definition
Objective [short] data sheet	Development	This document contains data from the objective specification for product development.
Preliminary [short] data sheet	Qualification	This document contains data from the preliminary specification.
Product [short] data sheet	Production	This document contains the product specification.

[1] Please consult the most recently issued document before initiating or completing a design.

[2] The term 'short data sheet' is explained in section "Definitions".

[3] The product status of device(s) described in this document may have changed since this document was published and may differ in case of multiple devices. The latest product status information is available on the Internet at URL <http://www.nxp.com>.

15.2 Definitions

Draft — A draft status on a document indicates that the content is still under internal review and subject to formal approval, which may result in modifications or additions. NXP Semiconductors does not give any representations or warranties as to the accuracy or completeness of information included in a draft version of a document and shall have no liability for the consequences of use of such information.

Short data sheet — A short data sheet is an extract from a full data sheet with the same product type number(s) and title. A short data sheet is intended for quick reference only and should not be relied upon to contain detailed and full information. For detailed and full information see the relevant full data sheet, which is available on request via the local NXP Semiconductors sales office. In case of any inconsistency or conflict with the short data sheet, the full data sheet shall prevail.

Product specification — The information and data provided in a Product data sheet shall define the specification of the product as agreed between NXP Semiconductors and its customer, unless NXP Semiconductors and customer have explicitly agreed otherwise in writing. In no event however, shall an agreement be valid in which the NXP Semiconductors product is deemed to offer functions and qualities beyond those described in the Product data sheet.

15.3 Disclaimers

Limited warranty and liability — Information in this document is believed to be accurate and reliable. However, NXP Semiconductors does not give any representations or warranties, expressed or implied, as to the accuracy or completeness of such information and shall have no liability for the consequences of use of such information. NXP Semiconductors takes no responsibility for the content in this document if provided by an information source outside of NXP Semiconductors.

In no event shall NXP Semiconductors be liable for any indirect, incidental, punitive, special or consequential damages (including - without limitation - lost profits, lost savings, business interruption, costs related to the removal or replacement of any products or rework charges) whether or not such damages are based on tort (including negligence), warranty, breach of contract or any other legal theory.

Notwithstanding any damages that customer might incur for any reason whatsoever, NXP Semiconductors' aggregate and cumulative liability towards customer for the products described herein shall be limited in accordance with the Terms and conditions of commercial sale of NXP Semiconductors.

Right to make changes — NXP Semiconductors reserves the right to make changes to information published in this document, including without limitation specifications and product descriptions, at any time and without notice. This document supersedes and replaces all information supplied prior to the publication hereof.

Suitability for use — NXP Semiconductors products are not designed, authorized or warranted to be suitable for use in life support, life-critical or safety-critical systems or equipment, nor in applications where failure or malfunction of an NXP Semiconductors product can reasonably be expected to result in personal injury, death or severe property or environmental damage. NXP Semiconductors and its suppliers accept no liability for inclusion and/or use of NXP Semiconductors products in such equipment or applications and therefore such inclusion and/or use is at the customer's own risk.

Applications — Applications that are described herein for any of these products are for illustrative purposes only. NXP Semiconductors makes no representation or warranty that such applications will be suitable for the specified use without further testing or modification.

Customers are responsible for the design and operation of their applications and products using NXP Semiconductors products, and NXP Semiconductors accepts no liability for any assistance with applications or customer product design. It is customer's sole responsibility to determine whether the NXP Semiconductors product is suitable and fit for the customer's applications and products planned, as well as for the planned application and use of customer's third party customer(s). Customers should provide appropriate design and operating safeguards to minimize the risks associated with their applications and products.

NXP Semiconductors does not accept any liability related to any default, damage, costs or problem which is based on any weakness or default in the customer's applications or products, or the application or use by customer's third party customer(s). Customer is responsible for doing all necessary testing for the customer's applications and products using NXP Semiconductors products in order to avoid a default of the applications and the products or of the application or use by customer's third party customer(s). NXP does not accept any liability in this respect.

Limiting values — Stress above one or more limiting values (as defined in the Absolute Maximum Ratings System of IEC 60134) will cause permanent damage to the device. Limiting values are stress ratings only and (proper) operation of the device at these or any other conditions above those given in the Recommended operating conditions section (if present) or the Characteristics sections of this document is not warranted. Constant or repeated exposure to limiting values will permanently and irreversibly affect the quality and reliability of the device.

Terms and conditions of commercial sale — NXP Semiconductors products are sold subject to the general terms and conditions of commercial sale, as published at <http://www.nxp.com/profile/terms>, unless otherwise agreed in a valid written individual agreement. In case an individual agreement is concluded only the terms and conditions of the respective agreement shall apply. NXP Semiconductors hereby expressly objects to applying the customer's general terms and conditions with regard to the purchase of NXP Semiconductors products by customer.

No offer to sell or license — Nothing in this document may be interpreted or construed as an offer to sell products that is open for acceptance or the grant, conveyance or implication of any license under any copyrights, patents or other industrial or intellectual property rights.

Quick reference data — The Quick reference data is an extract of the product data given in the Limiting values and Characteristics sections of this document, and as such is not complete, exhaustive or legally binding.

Export control — This document as well as the item(s) described herein may be subject to export control regulations. Export might require a prior authorization from competent authorities.

Suitability for use in non-automotive qualified products — Unless this data sheet expressly states that this specific NXP Semiconductors product is automotive qualified, the product is not suitable for automotive use. It is neither qualified nor tested in accordance with automotive testing or application requirements. NXP Semiconductors accepts no liability for inclusion and/or use of non-automotive qualified products in automotive equipment or applications.

In the event that customer uses the product for design-in and use in automotive applications to automotive specifications and standards, customer (a) shall use the product without NXP Semiconductors' warranty of the product for such automotive applications, use and specifications, and (b) whenever customer uses the product for automotive applications beyond NXP Semiconductors' specifications such use shall be solely at customer's own risk, and (c) customer fully indemnifies NXP Semiconductors for any liability, damages or failed product claims resulting from customer design and use of the product for automotive applications beyond NXP Semiconductors' standard warranty and NXP Semiconductors' product specifications.

Translations — A non-English (translated) version of a document, including the legal information in that document, is for reference only. The English version shall prevail in case of any discrepancy between the translated and English versions.

Security — Customer understands that all NXP products may be subject to unidentified vulnerabilities or may support established security standards or specifications with known limitations. Customer is responsible for the design and operation of its applications and products throughout their lifecycles to reduce the effect of these vulnerabilities on customer's applications and products. Customer's responsibility also extends to other open and/or proprietary technologies supported by NXP products for use in customer's applications. NXP accepts no liability for any vulnerability. Customer should regularly check security updates from NXP and follow up appropriately.

Customer shall select products with security features that best meet rules, regulations, and standards of the intended application and make the ultimate design decisions regarding its products and is solely responsible for compliance with all legal, regulatory, and security related requirements concerning its products, regardless of any information or support that may be provided by NXP.

NXP has a Product Security Incident Response Team (PSIRT) (reachable at PSIRT@nxp.com) that manages the investigation, reporting, and solution release to security vulnerabilities of NXP products.

15.4 Trademarks

Notice: All referenced brands, product names, service names, and trademarks are the property of their respective owners.

NXP — wordmark and logo are trademarks of NXP B.V.

GreenChip — is a trademark of NXP B.V.