



PART NO. : TG110-5006N1RL

16PIN SMT ISOLATION MODULE FOR 10/100BASE-TX
IEEE802.3u APPLICATIONS

RoHS COMPLIANT

COMPATIBLE TO LEAD-FREE SOLDERING PROCESS
CONDITION PER IPC/JEDEC J-STD-020C

UL/EN60950 AND DEMKO RECOGNIZED

OPERATING TEMPERATURE 0/+70°C

ELECTRICAL SPECIFICATIONS @25°C

URNS RATIO

P1-3:P16-14

1CT:1CT ±3%

P6-8:P11-9

1CT:1CT ±3%

OCL (100KHz,0.1Vrms,8mA)

P1-3,P6-8

350µH min

DCR P9-11,P14-16

0.9Ω max

LL P1-3,P6-8

0.4µH max

Cw/w

35pF max

INSERTION LOSS

0.1-100MHz

-1.1dB max

RETURN LOSS

0.5-30MHz

-18dB min

40MHz

-15.5dB min

50MHz

-13.6dB min

60-80MHz

-12dB min

CROSSTALK 0.1-100MHz

-40dB min

ISOLATION

1,500Vrms

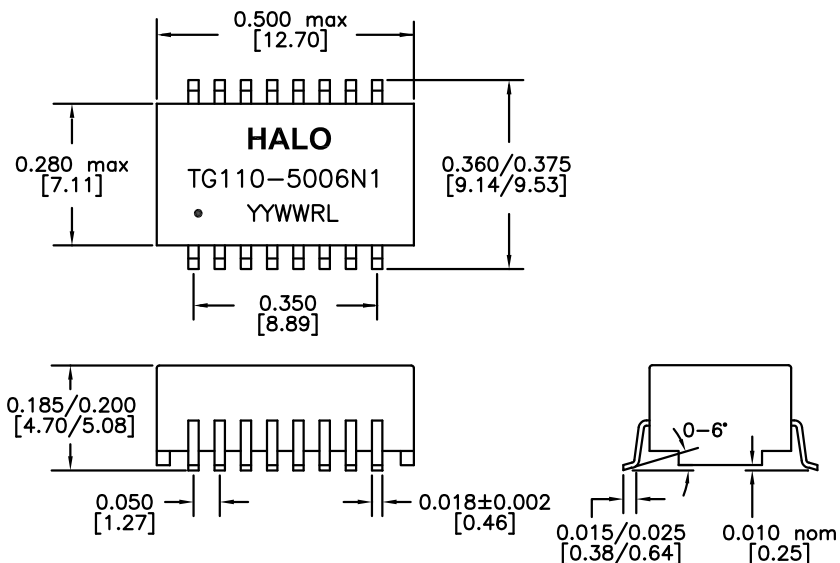

DIMENSIONS: Inch [mm]
CO-PLANARITY: 0.004 [0.10]
TOLERANCES: ±0.005 INCH IF NOT SPECIFIED

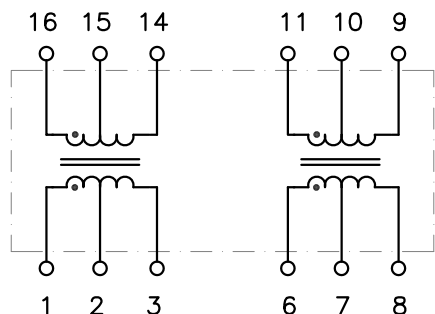

HALO/PBL

CALIFORNIA, USA
KOWLOON, HONG KONG
SINGAPORE

TITLE ISOLATION TRANSFORMERS

FOR FAST ETHERNET

PART NO. TG110-5006N1RL

SCALE NONE PAGE 1 OF 2

SIGNATURES

DRAWN LI ZHI ZHONG

DATE

6/4/07

REV.

A

DESC.

FIRST ISSUE

DATE

6/4/07

CHECKED LEI KEONG

8/5/13

B

PROD. RELEASE

8/5/13

APPROVED PETER LU

8/5/13

FILE 110-5006RL.DWG

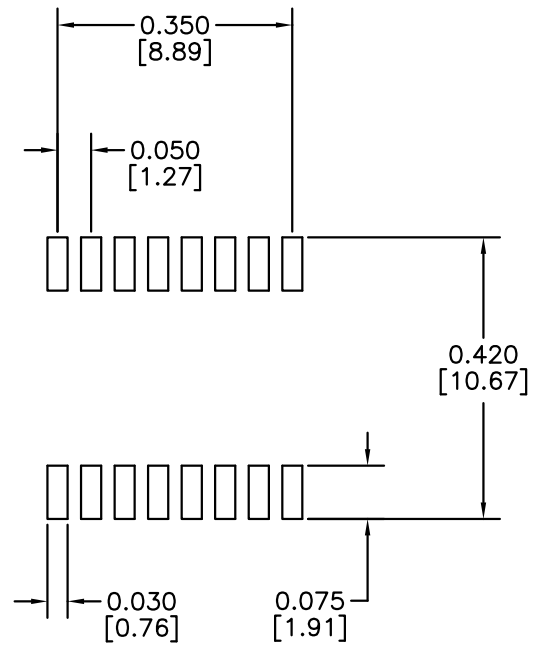

RECOMMENDED SOLDER PAD DIMENSIONS
 DIMENSIONS: Inch [mm]

HALO/PBL	TITLE ISOLATION TRANSFORMERS		SIGNATURES		DATE	REV.	DESC.	DATE
	FOR FAST ETHERNET		DRAWN	LI ZHI ZHONG	6/4/07	A	FIRST ISSUE	6/4/07
	PART NO. TG110-5006N1RL		CHECKED	LEI KEONG	8/5/13	B	PROD. RELEASE	8/5/13
	SCALE NONE		PAGE	2 OF 2	APPROVED	PETER LU	8/5/13	
CALIFORNIA, USA KOWLOON, HONG KONG SINGAPORE		FILE		110-5006RL.DWG				