

DIMENSIONS: Inch [mm]
CO-PLANARITY: 0.004 [0.10]
TOLERANCES: ±0.005 INCH IF NOT SPECIFIED

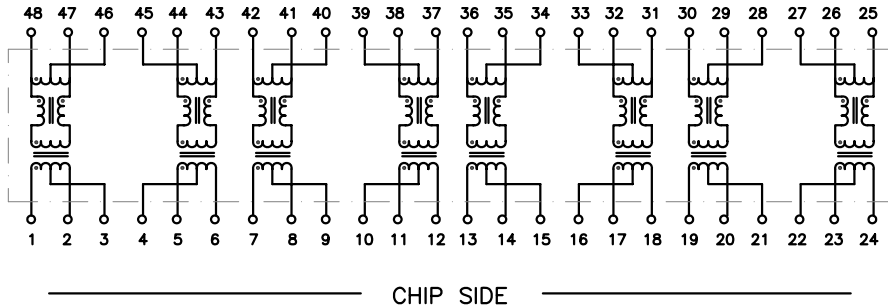

PART NO. : TG110-RP16NV6RL

FOUR PORT FAST ETHERNET ISOLATION MODULE
COMPLIANT WITH IEEE802.3af REQUIREMENTS
350mA CURRENT CARRYING CAPACITY ON LINE-SIDE
FOR PoE APPLICATIONS
RoHS COMPLIANT
COMPATIBLE TO LEAD-FREE SOLDERING PROCESS
CONDITION PER IPC/JEDEC J-STD-020C
OPERATING TEMPERATURE 0/+70°C

ELECTRICAL SPECIFICATIONS @ 25° C

URNS RATIO	1CT:1CT ±2%
OCL (100KHz,0.1Vrms,8mA)	350µH min
DCR (CHIP SIDE)	0.9Ω max
INSERTION LOSS	
0.1-100MHz	-1.1dB max
RETURN LOSS	
0.5-30MHz	-18dB min
40MHz	-16dB min
50MHz	-13dB min
60-80MHz	-12dB min
CMR 0.1-100MHz	-40dB typ
CROSSTALK 0.1-100MHz	-40dB typ
ISOLATION	1,500Vrms



HALO/PBL

CALIFORNIA, USA
KOWLOON, HONG KONG
SINGAPORE

TITLE	ISOLATION MODULE		SIGNATURES	DATE	REV.	DESC.	DATE
FOR	FAST ETHERNET, PoE		DRAWN PETER LU	12/16/05	A	FIRST ISSUE	12/16/05
PART NO.	TG110-RP16NV6RL		CHECKED LEI KEONG	2/8/06	B	PROD. RELEASE	2/8/06
SCALE	NONE	PAGE	1 OF 1	APPROVED PETER LU	2/8/06		
				FILE	RP16NV6RL.DWG		