

### Product Description

Qorvo's TGS2313 is a 4-18 GHz Single Pole Triple Throw (SP3T) Switch. This part is designed using Qorvo's proven standard VPIN production process.

The TGS2313 provides a nominal 1.0 dB insertion loss, 12 dB return loss, and 35 dB isolation.

The TGS2313 integrated DC blocking capacitors on all ports and includes decoupled DC bias pads to reduce the number of off-chip components.

The part is ideally suited for EW receivers, radar, and communication systems.



### Block Diagram

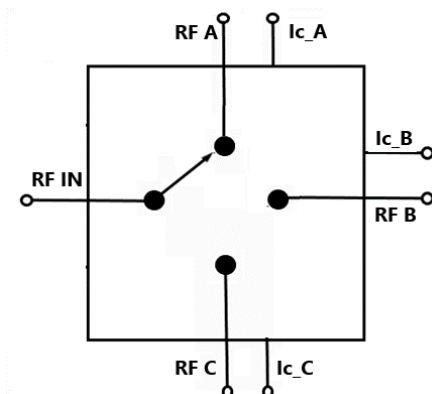

### Product Features

- Frequency Range: 4 - 18 GHz
- Insertion Loss: 1.0 dB
- Isolation: 35 dB Nominal
- Return Loss: 12dB Typical.
- On-Chip Bias Network
- DC Blocked at RF ports
- Die Dimensions: 2.06 x 2.03 x 0.10 mm

*Performance is typical across frequency. Please reference electrical specification table and data plots for more details.*

### Applications

- EW Receivers
- Radar
- Communications Systems

### Ordering Information

Part No.	Description
TGS2313	4 - 18 GHz High Isolation Switch



# TGS2313

## 4 – 18 GHz VPIN SP3T Switch

### Absolute Maximum Ratings

Parameter	Value
Positive Supply Voltage (V <sup>+</sup> )	+3 V
Negative Supply Voltage (V <sup>-</sup> )	-3 V
Positive Supply Current (I <sup>+</sup> )	22 mA
Power Dissipation, (P <sub>DISS</sub> ), CW, T = 25°C	0.45 W
RF Input Power, CW, 50 Ω, T = 25°C	24 dBm
Mounting Temperature (30 sec)	320 °C
Storage Temperature	-65 to 150

Operation of this device outside the parameter ranges given above may cause permanent damage. These are stress ratings only, and functional operation of the device at these conditions is not implied.

### Recommended Operating Conditions

Parameter	Min	Typ	Max	Units
Frequency	4		18	GHz
Input Power Handling (CW)		24		dBm
Control Current (I <sub>CONTROL</sub> )		±20		mA

Electrical specifications are measured at specified test conditions. Specifications are not guaranteed over all recommended operating conditions.

### Electrical Specifications

Test conditions unless otherwise noted: CW RF Input, Temp = +25 °C, Bias Conditions: I<sub>c</sub> = ±20 mA, See Function Table on page 4

Parameter	Conditions	Min	Typical	Max	Units
Operational Frequency Range		4		18	GHz
Insertion Loss	On-State		1.0		dB
Input Return Loss – Common Port RL	On-State		12		dB
Output Return Loss – Switched Port RL	On-State		12		dB
Isolation	Off-State		35		dB
Input Power			24		dBm

### Performance Plots –

Test conditions unless otherwise noted: CW RF Input, Temp= +25 °C, Bias Conditions: I<sub>CONTROL</sub> = ±20 mA

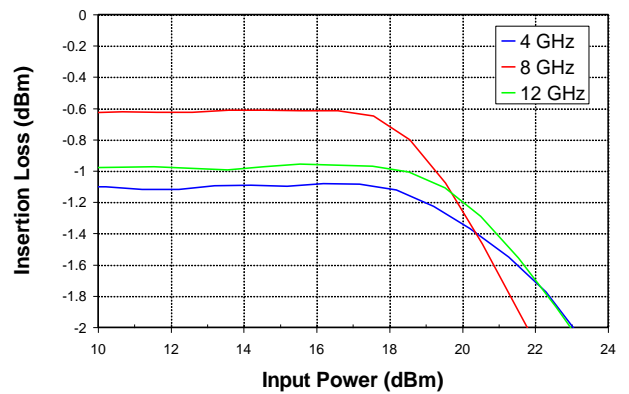
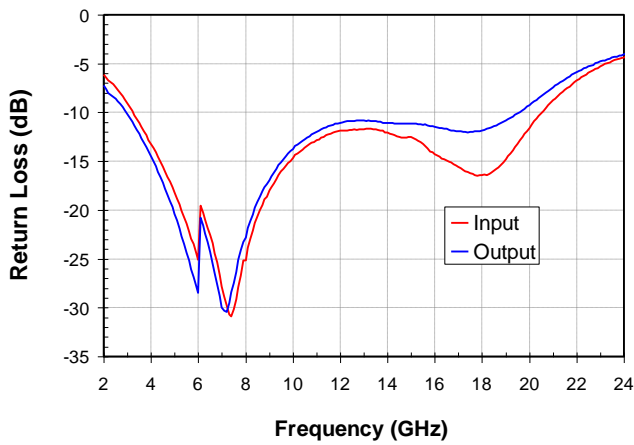
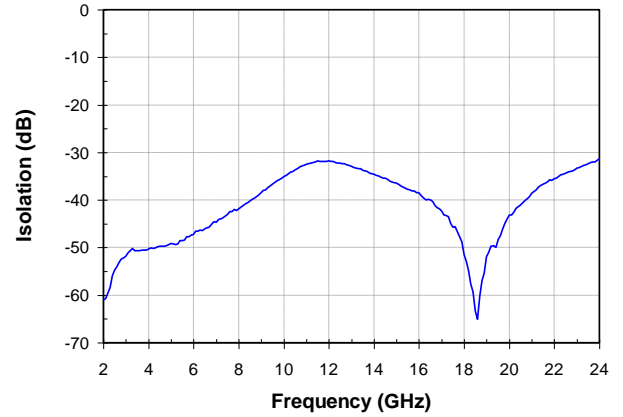
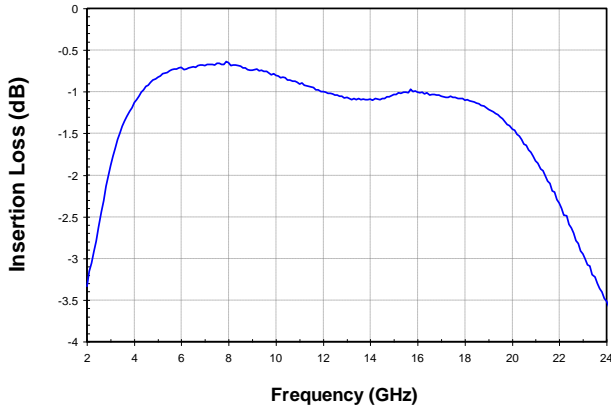

### Applications Circuit

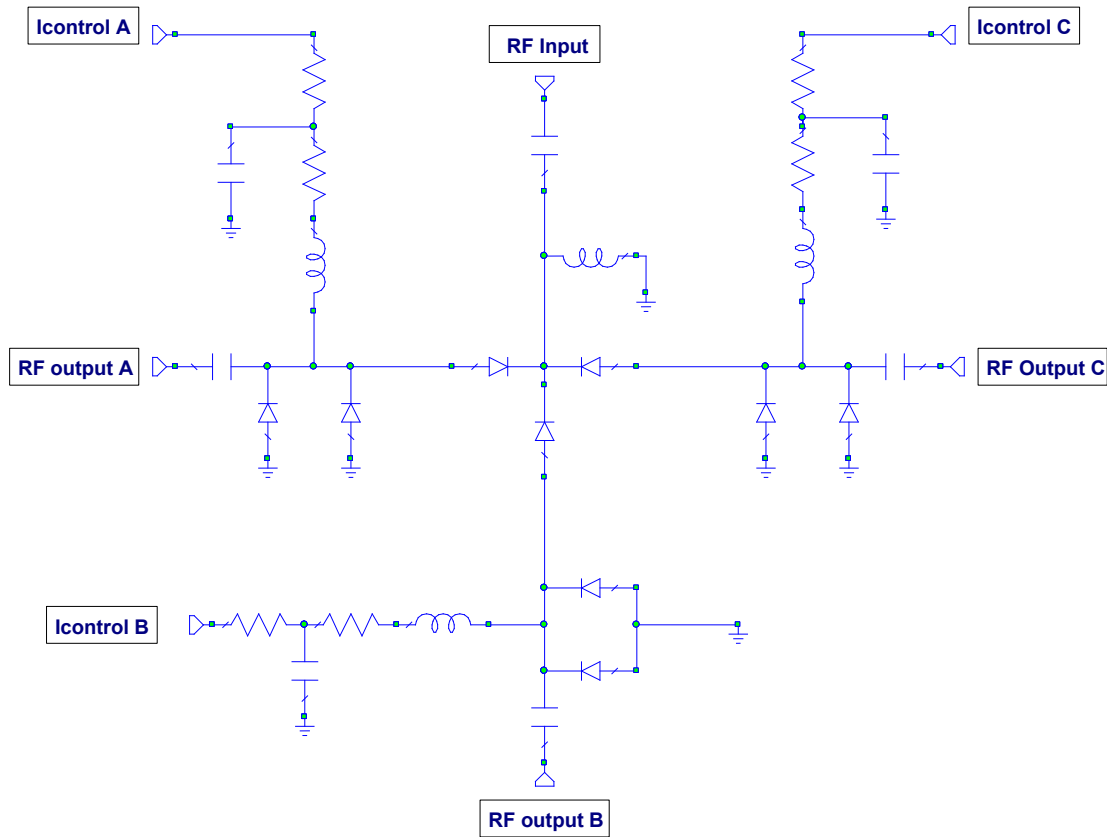

### Function Table

State	RF-A	RF-B	RF-C	I <sub>CONTROL A</sub>	I <sub>CONTROL B</sub>	I <sub>CONTROL C</sub>
1	Low-Loss	Isolated	Isolated	+20 mA	-20 mA	-20 mA
2	Isolated	Low-Loss	Isolated	-20 mA	+20 mA	-20 mA
3	Isolated	Isolated	Low-Loss	-20 mA	-20 mA	+20 mA

Notes: Typical DC voltage to achieve  $\pm 20$  mA at I<sub>CONTROL</sub> node is  $\pm 2.6$  -  $\pm 2.8$  V

## Assembly Drawing

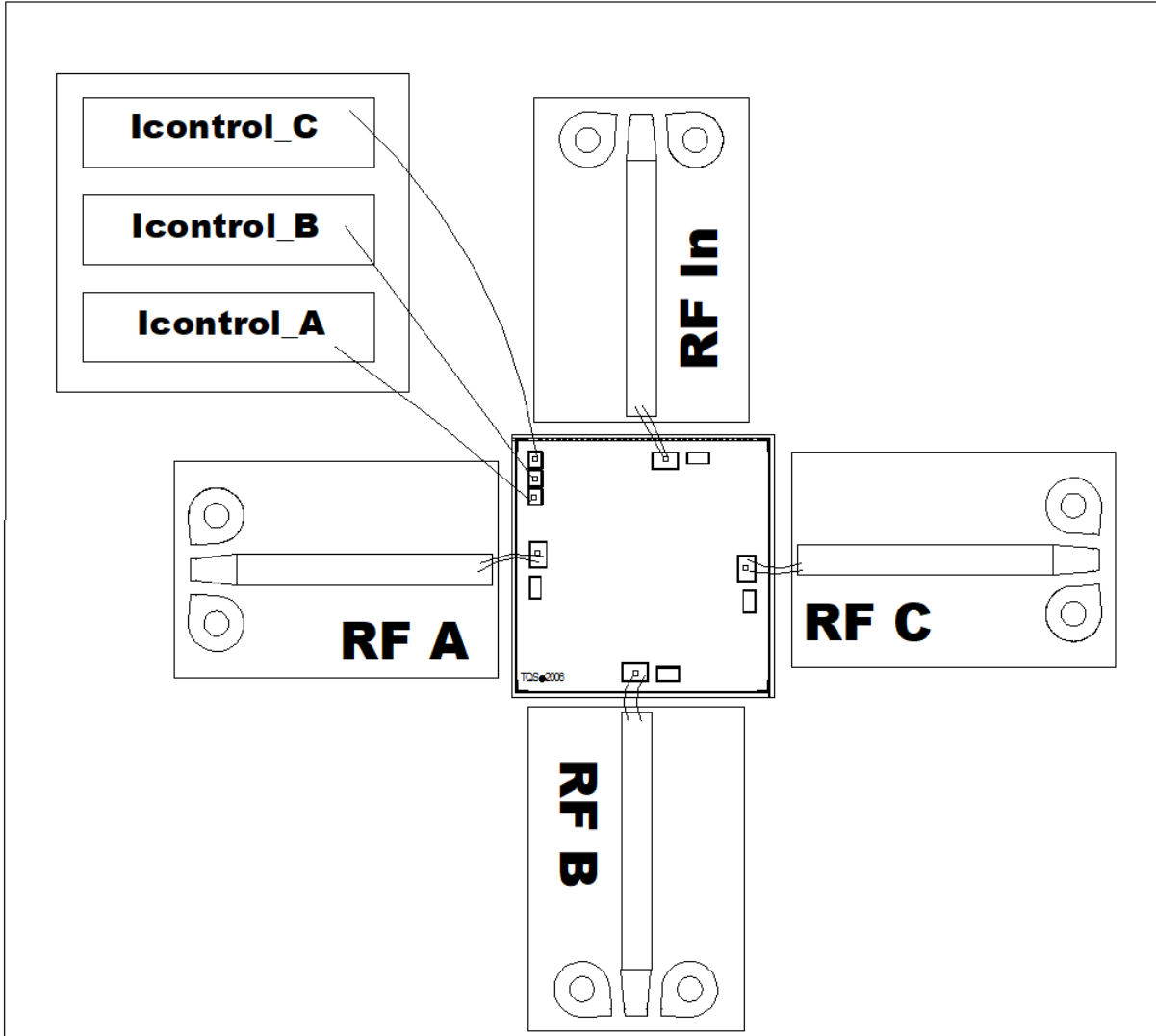

Note:

$\pm 20\text{mA}$  control lines (I<sub>CONTROL A</sub>, I<sub>CONTROL B</sub>, I<sub>CONTROL C</sub>) use on-chip resistors for diode current control.

### Mechanical Drawing and Bond Pad Description

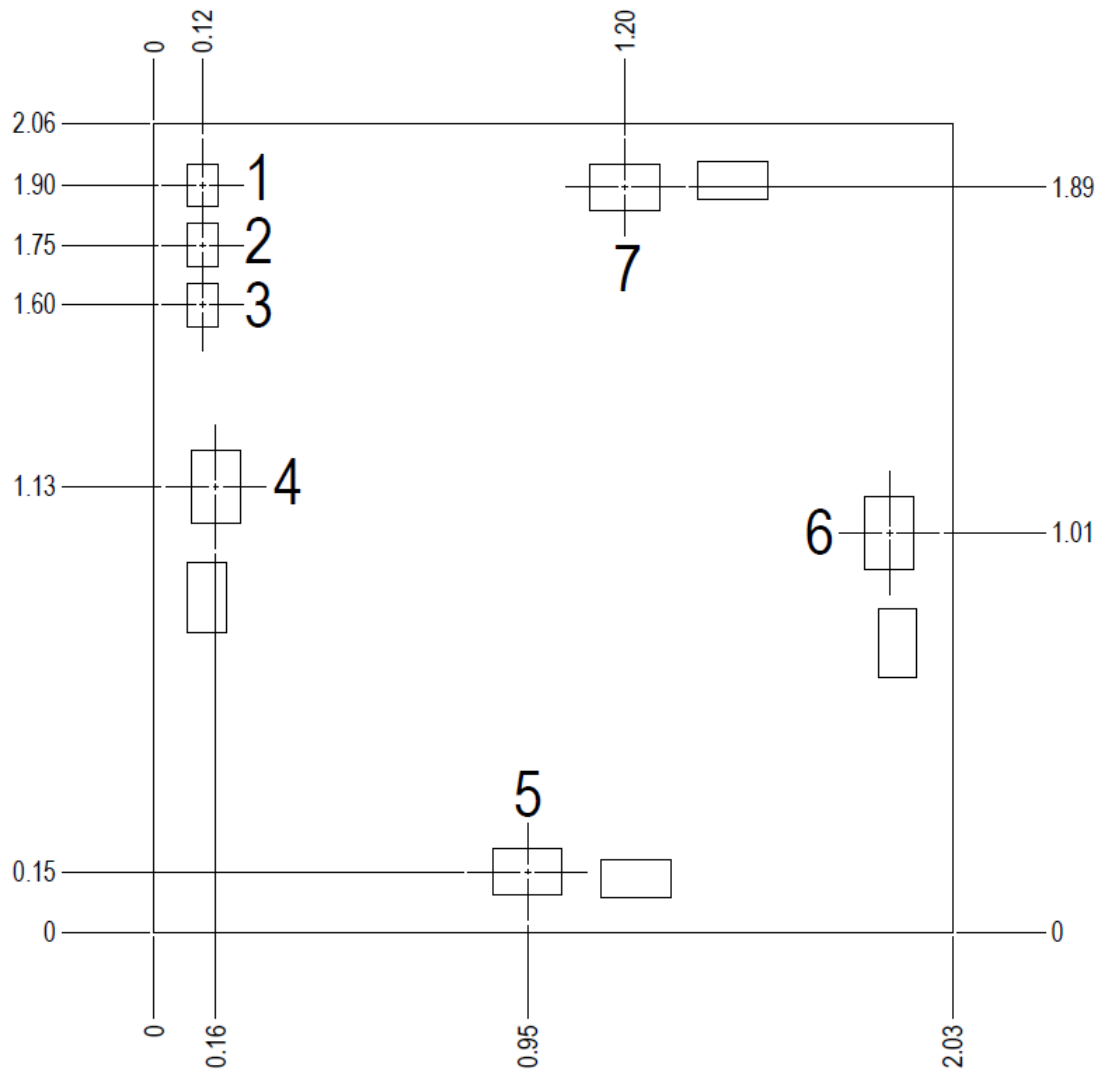

Pin No.	Symbol	Description	Pad Size (mm)
1	V <sub>C</sub>	Control voltage C	0.078 x 0.109
2	V <sub>B</sub>	Control voltage B	0.078 x 0.109
3	V <sub>A</sub>	Control voltage A	0.078 x 0.109
4	RF Output A	Output A, RF switched port A; matched to 50 Ω; DC coupled	0.127 x 0.185
5	RF Output B	Output B, RF switched port B; matched to 50 Ω; DC coupled	0.176 x 0.118
6	RF Output C	Output C, RF switched port C; matched to 50 Ω; DC coupled	0.125 x 0.185
7	RF Input	Input, RF common port; matched to 50 Ω; DC coupled	0.176 x 0.118

Thickness: 0.100 mm  
 Chip edge to bond pad dimensions is shown to center of bond pad  
 Chip size tolerance: ± 0.050 mm  
 GND is backside of MMIC

## Assembly Notes

---

Component placement and adhesive attachment assembly notes:

- Vacuum pencils and/or vacuum collets are the preferred method of pick up.
- Air bridges must be avoided during placement.
- The force impact is critical during auto placement.
- Organic attachment (i.e., conductive epoxy) can be used in low-power applications.
- Curing should be done in a convection oven; proper exhaust is a safety concern.

Reflow process assembly notes:

- Use AuSn (80/20) solder and limit exposure to temperatures above 300 °C to 3–4 minutes, maximum.
- An alloy station or conveyor furnace with reducing atmosphere should be used.
- Do not use any kind of flux.
- Coefficient of thermal expansion matching is critical for long-term reliability.
- Devices must be stored in a dry nitrogen atmosphere.

Interconnect process assembly notes:

- Thermosonic ball bonding is the preferred interconnect technique.
- Force, time, and ultrasonic are critical parameters.
- Aluminum wire should not be used.
- Devices with small pad sizes should be bonded with 0.0007-inch wire.