

Complementary power Darlingtons

Datasheet — production data

Features

- Monolithic Darlingtons configuration
- Integrated antiparallel collector-emitter diode

Applications

- Linear and switching industrial equipment

Description

The devices are manufactured in planar technology with “base island” layout and monolithic Darlingtons configuration. The resulting transistors show exceptional high gain performance coupled with very low saturation voltage.

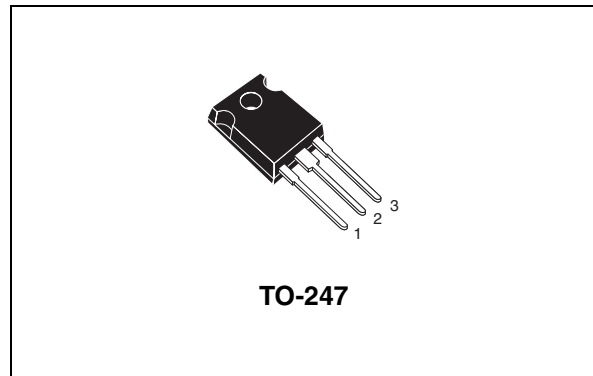

Figure 1. Internal schematic diagrams

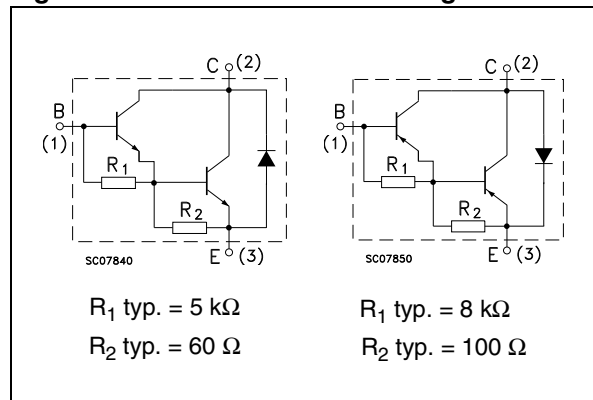

Table 1. Device summary

Part number	Marking	Polarity	Package	Packaging
TIP142	TIP142	NPN	TO-247	Tube
TIP147	TIP147	PNP		

1 Absolute maximum ratings

Table 2. Absolute maximum ratings

Symbol	Parameter	Value	Unit
V_{CBO}	Collector-base voltage ($I_E = 0$)	100	V
V_{CEO}	Collector-emitter voltage ($I_B = 0$)	100	V
V_{EBO}	Emitter-base voltage ($I_C = 0$)	5	V
I_C	Collector current	10	A
I_{CM}	Collector peak current	20	A
I_B	Base current	0.5	A
P_{TOT}	Total dissipation at $T_{case} = 25\text{ °C}$	125	W
T_{STG}	Storage temperature	-65 to 150	°C
T_J	Max. operating junction temperature	150	°C

Note: For PNP type voltage and current are negative.

Table 3. Thermal data

Symbol	Parameter	Value	Unit
R_{thJC}	Thermal resistance junction-case	max 1	°C/W

2 Electrical characteristics

$T_{\text{case}} = 25\text{ }^{\circ}\text{C}$; unless otherwise specified.

Table 4. Electrical characteristics

Symbol	Parameter	Test conditions	Min.	Typ.	Max.	Unit
I_{CBO}	Collector cut-off current ($I_{\text{E}} = 0$)	$V_{\text{CB}} = 100\text{ V}$			1	mA
I_{CEO}	Collector cut-off current ($I_{\text{B}} = 0$)	$V_{\text{CE}} = 50\text{ V}$			2	mA
I_{EBO}	Emitter cut-off current ($I_{\text{C}} = 0$)	$V_{\text{EB}} = 5\text{ V}$			2	mA
$V_{\text{CEO(sus)}}^{(1)}$	Collector-emitter sustaining voltage ($I_{\text{B}} = 0$)	$I_{\text{C}} = 30\text{ mA}$	100			V
$V_{\text{CE(sat)}}^{(1)}$	Collector-emitter saturation voltage	$I_{\text{C}} = 5\text{ A}$ $I_{\text{B}} = 10\text{ mA}$ $I_{\text{C}} = 10\text{ A}$ $I_{\text{B}} = 40\text{ mA}$			2 3	V V
$V_{\text{BE(on)}}^{(1)}$	Base-emitter on voltage	$I_{\text{C}} = 10\text{ A}$ $V_{\text{CE}} = 4\text{ V}$			3	V
$h_{\text{FE}}^{(1)}$	DC current gain	$I_{\text{C}} = 5\text{ A}$ $V_{\text{CE}} = 4\text{ V}$ $I_{\text{C}} = 10\text{ A}$ $V_{\text{CE}} = 4\text{ V}$	1000 500			
t_{on} t_{off}	Resistive load Turn-on time Turn-off time	$I_{\text{C}} = 10\text{ A}$ $R_{\text{L}} = 3\text{ }\Omega$ $I_{\text{B1}} = -I_{\text{B2}} = 40\text{ mA}$		0.9 4		μs μs

1. Pulse test: pulse duration $\leq 300\text{ }\mu\text{s}$, duty cycle $\leq 2\%$.

For PNP type voltage and current are negative.

3 Electrical characteristics (curve)

Figure 2. Safe operating area

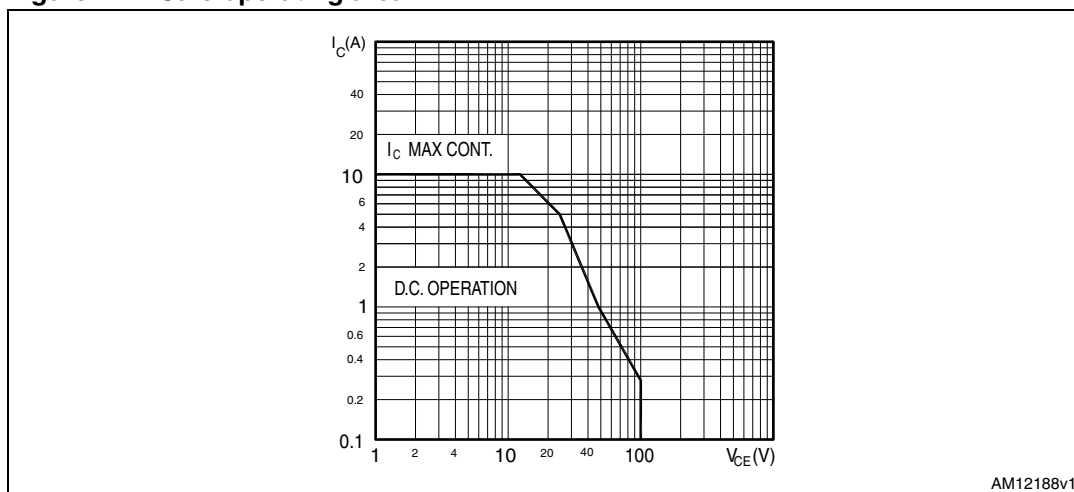

4 Test circuits

Figure 3. Resistive load switching test circuit (NPN type)

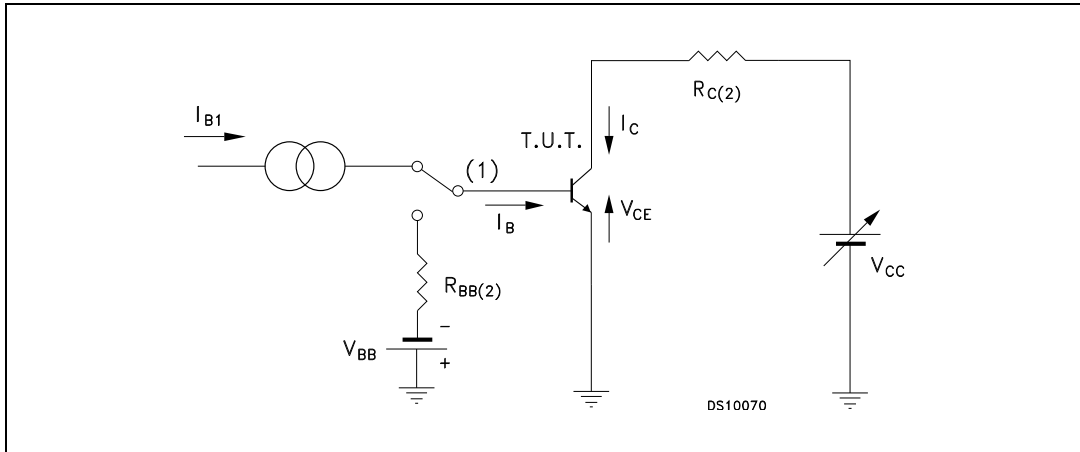

1. Fast electronic switch
2. Non-inductive resistor

Figure 4. Resistive load switching test circuit (PNP type)

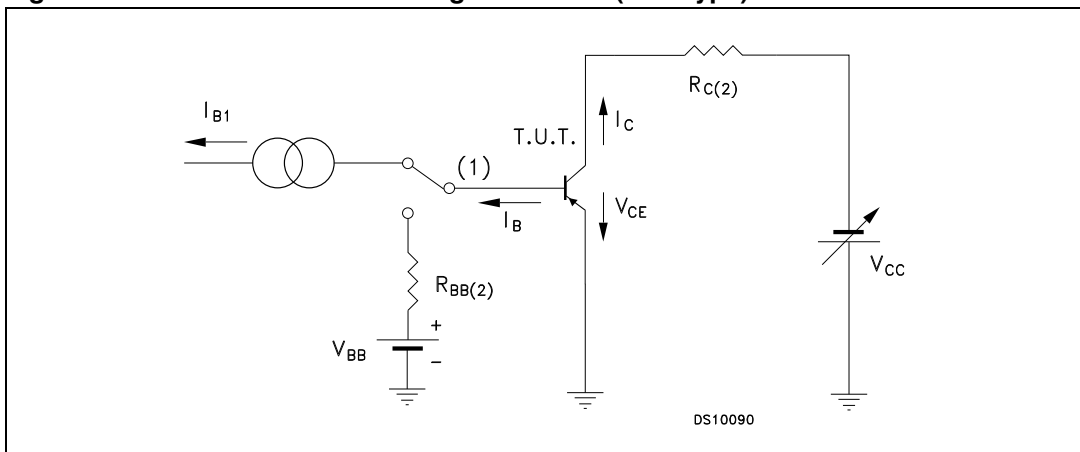

1. Fast electronic switch
2. Non-inductive resistor

5 Package mechanical data

In order to meet environmental requirements, ST offers these devices in different grades of ECOPACK[®] packages, depending on their level of environmental compliance. ECOPACK[®] specifications, grade definitions and product status are available at: www.st.com. ECOPACK[®] is an ST trademark.

Table 5. TO-247 mechanical data

Dim.	mm.		
	Min.	Typ.	Max.
A	4.85		5.15
A1	2.20		2.60
b	1.0		1.40
b1	2.0		2.40
b2	3.0		3.40
c	0.40		0.80
D	19.85		20.15
E	15.45		15.75
e	5.30	5.45	5.60
L	14.20		14.80
L1	3.70		4.30
L2		18.50	
ØP	3.55		3.65
ØR	4.50		5.50
S	5.30	5.50	5.70

Figure 5. TO-247 drawing

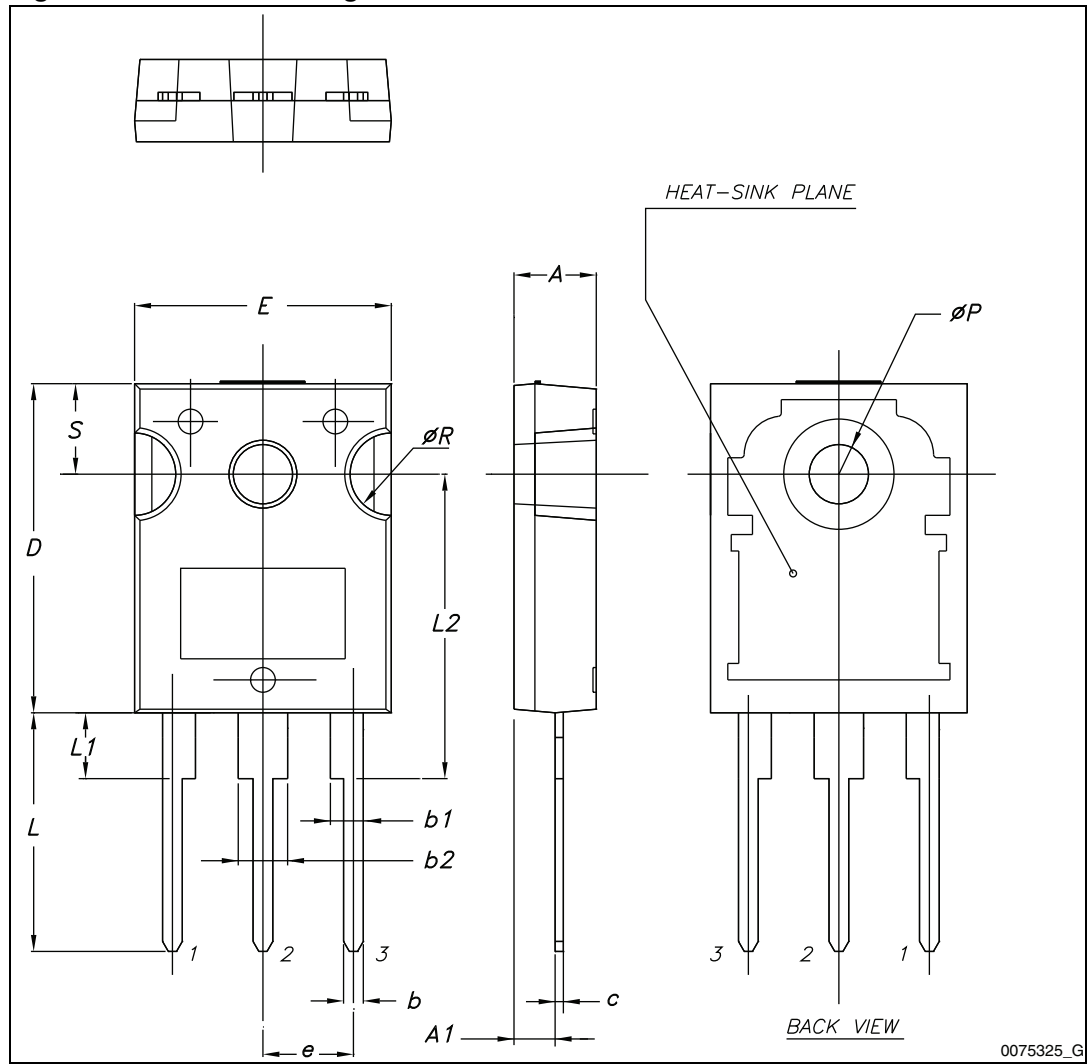

6 Revision history

Table 6. Document revision history

Date	Revision	Changes
15-Oct-2007	6	Package change from SOT-93 to TO-247.
12-May-2010	7	Technology change from epitaxial base to planar base island.
19-Apr-2012	8	Added: Figure 2: Safe operating area Updated: mechanical data