

Complementary power transistors

Features

- Low collector-emitter saturation voltage
- Complementary NPN - PNP transistors

Applications

- General purpose
- Audio Amplifier

Description

The devices are manufactured in epitaxial-base planar technology and are suitable for audio, power linear and switching applications.

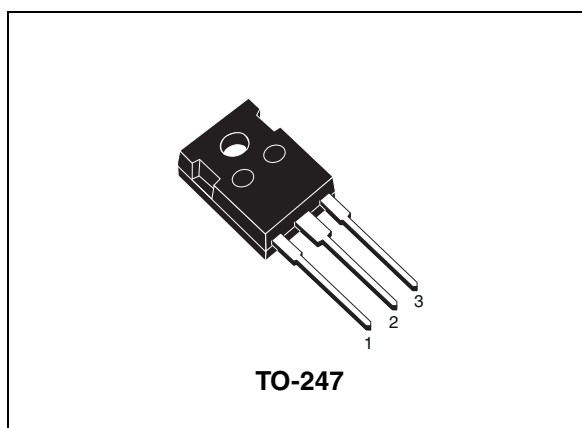

Figure 1. Internal schematic diagrams

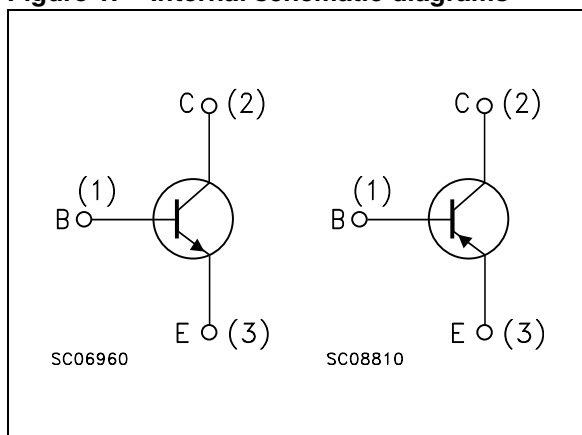

Table 1. Device summary

Order code	Marking	Package	Packaging
TIP2955	TIP2955	TO-247	tube
TIP3055	TIP3055		

1 Absolute maximum rating

Table 2. Absolute maximum rating

Symbol	Parameter	Value		Unit
		NPN	TIP3055	
		PNP	TIP2955	
V_{CBO}	Collector-emitter voltage ($I_E = 0$)	100		V
V_{CER}	Collector-emitter voltage ($R_{BE} = 100 \Omega$)	70		V
V_{CEO}	Collector-emitter voltage ($I_B = 0$)	60		V
V_{EBO}	Collector-base voltage ($I_C = 0$)	7		V
I_C	Collector current	15		A
I_B	Base current	7		A
P_{tot}	Total dissipation at $T_c \leq 25^\circ\text{C}$	90		W
T_{stg}	Storage temperature	-65 to 150		$^\circ\text{C}$
T_J	Max. operating junction temperature	150		$^\circ\text{C}$

Note: For PNP type voltage and current values are negative

2 Electrical characteristics

($T_{\text{case}} = 25\text{ °C}$; unless otherwise specified)

Table 3. Electrical characteristics

Symbol	Parameter	Test conditions	Min.	Typ.	Max.	Unit
I_{CEX}	Collector cut-off current ($V_{\text{BE}} = -1.5\text{ V}$)	$V_{\text{CE}} = 100\text{ V}$ $V_{\text{CE}} = 100\text{ V}$ $T_{\text{C}} = 150\text{ °C}$			1 5	mA mA
I_{CEO}	Collector cut-off current ($I_{\text{B}} = 0$)	$V_{\text{CE}} = 30\text{ V}$			0.7	mA
I_{EBO}	Emitter cut-off current ($I_{\text{C}} = 0$)	$V_{\text{EB}} = 7\text{ V}$			5	mA
$V_{\text{CEO(sus)}}^{(1)}$	Collector-emitter sustaining voltage ($I_{\text{B}} = 0$)	$I_{\text{C}} = 200\text{ mA}$	60			V
$V_{\text{CER(sus)}}^{(1)}$	Collector-emitter sustaining voltage ($R_{\text{BE}} = 100\ \Omega$)	$I_{\text{C}} = 200\text{ mA}$	70			V
$V_{\text{CE(sat)}}^{(1)}$	Collector-emitter saturation voltage	$I_{\text{C}} = 4\text{ A}$ $I_{\text{B}} = 400\text{ mA}$ $I_{\text{C}} = 10\text{ A}$ $I_{\text{B}} = 3.3\text{ A}$			1 3	V V
$V_{\text{BE}}^{(1)}$	Base-emitter voltage	$I_{\text{C}} = 4\text{ A}$ $V_{\text{CE}} = 4\text{ V}$			1.8	V
$h_{\text{FE}}^{(1)}$	DC current gain	$I_{\text{C}} = 4\text{ A}$ $V_{\text{CE}} = 4\text{ V}$ $I_{\text{C}} = 10\text{ A}$ $V_{\text{CE}} = 4\text{ V}$	20 5		70	

1. Pulse duration = 300 μs , duty cycle $\leq 1.5\%$

Note: For PNP type voltage and current values are negative

3 Package mechanical data

In order to meet environmental requirements, ST offers these devices in ECOPACK® packages. These packages have a Lead-free second level interconnect . The category of second level interconnect is marked on the package and on the inner box label, in compliance with JEDEC Standard JESD97. The maximum ratings related to soldering conditions are also marked on the inner box label. ECOPACK is an ST trademark. ECOPACK specifications are available at : www.st.com

TO-247 Mechanical data

Dim.	mm.		
	Min.	Typ	Max.
A	4.85		5.15
A1	2.20		2.60
b	1.0		1.40
b1	2.0		2.40
b2	3.0		3.40
c	0.40		0.80
D	19.85		20.15
E	15.45		15.75
e		5.45	
L	14.20		14.80
L1	3.70		4.30
L2		18.50	
øP	3.55		3.65
øR	4.50		5.50
S		5.50	

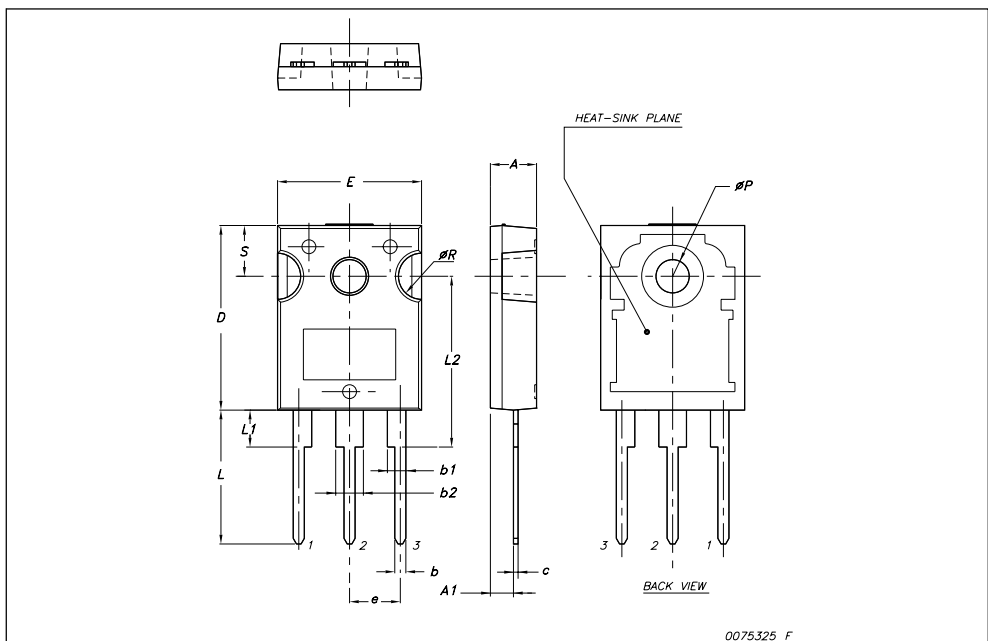

4 Revision history

Table 4. Document revision history

Date	Revision	Changes
30-Aug-1999	4	
10-Jan-2008	5	Package change from TO-218 to TO-247.