

## Complementary power transistors

### Features

- Low collector-emitter saturation voltage
- Complementary NPN - PNP transistors

### Applications

- General purpose
- Audio amplifier

### Description

The devices are manufactured in planar technology with “base island” layout. The resulting transistors show exceptional high gain performance coupled with very low saturation voltage.

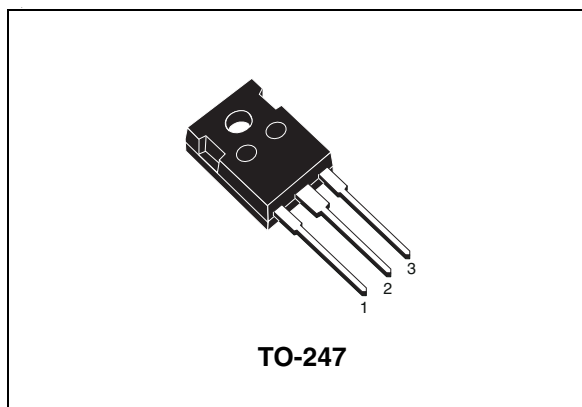

**Figure 1. Internal schematic diagrams**

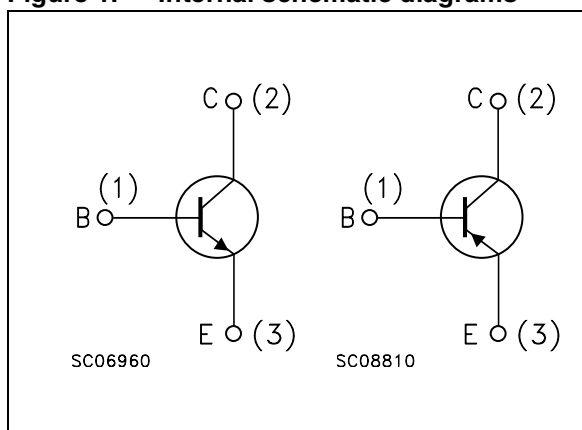

**Table 1. Device summary**

Order code	Marking	Package	Packaging
TIP35C	TIP35C	TO-247	Tube
TIP36C	TIP36C		

# 1 Electrical ratings

**Table 2. Absolute maximum ratings**

Symbol	Parameter		Value	Unit
		NPN	TIP35C	
		PNP	TIP36C	
$V_{CBO}$	Collector-base voltage ( $I_E = 0$ )		100	V
$V_{CEO}$	Collector-emitter voltage ( $I_B = 0$ )		100	V
$V_{EBO}$	Emitter-base voltage ( $I_C = 0$ )		5	V
$I_C$	Collector current		25	A
$I_{CM}$	Collector peak current ( $t_p < 5$ ms)		50	A
$I_B$	Base current		5	A
$P_{tot}$	Total dissipation at $T_{case} = 25$ °C		125	W
$T_{stg}$	Storage temperature		-65 to 150	°C
$T_J$	Max. operating junction temperature		150	°C

For PNP type voltage and current values are negative.

**Table 3. Thermal data**

Symbol	Parameter		Value	Unit
$R_{thj-case}$	Thermal resistance junction-case	max	1	°C/W

## 2 Electrical characteristics

( $T_{\text{case}} = 25\text{ }^{\circ}\text{C}$ ; unless otherwise specified)

**Table 4. Electrical characteristics**

Symbol	Parameter	Test conditions	Min.	Typ.	Max.	Unit
$I_{\text{CEO}}$	Collector cut-off current ( $I_{\text{B}} = 0$ )	$V_{\text{CE}} = 60\text{ V}$			1	mA
$I_{\text{EBO}}$	Emitter cut-off current ( $I_{\text{C}} = 0$ )	$V_{\text{EB}} = 5\text{ V}$			1	mA
$I_{\text{CES}}$	Collector cut-off current ( $V_{\text{BE}} = 0$ )	$V_{\text{CE}} = 100\text{ V}$			0.7	mA
$V_{\text{CEO(sus)}}^{(1)}$	Collector-emitter sustaining voltage ( $I_{\text{B}} = 0$ )	$I_{\text{C}} = 30\text{ mA}$	100			V
$V_{\text{CE(sat)}}^{(1)}$	Collector-emitter saturation voltage	$I_{\text{C}} = 15\text{ A}$			1.8	V
		$I_{\text{C}} = 25\text{ A}$			4	V
$V_{\text{BE(on)}}^{(1)}$	Base-emitter voltage	$I_{\text{C}} = 15\text{ A}$	$V_{\text{CE}} = 4\text{ V}$		2	V
		$I_{\text{C}} = 25\text{ A}$	$V_{\text{CE}} = 4\text{ V}$		4	V
$h_{\text{FE}}^{(1)}$	DC current gain	$I_{\text{C}} = 1.5\text{ A}$	$V_{\text{CE}} = 4\text{ V}$	25		
		$I_{\text{C}} = 15\text{ A}$	$V_{\text{CE}} = 4\text{ V}$	10		50
$f_{\text{T}}$	Transition frequency	$I_{\text{C}} = 1\text{ A}$ $f = 1\text{ MHz}$	$V_{\text{CE}} = 10\text{ V}$	3		MHz

1. Pulsed duration = 300 ms, duty cycle  $\geq 1.5\%$ .

For PNP type voltage and current are negative.

## 2.1 Electrical characteristic (curves)

Figure 2. DC current gain for NPN type      Figure 3. DC current gain for PNP type

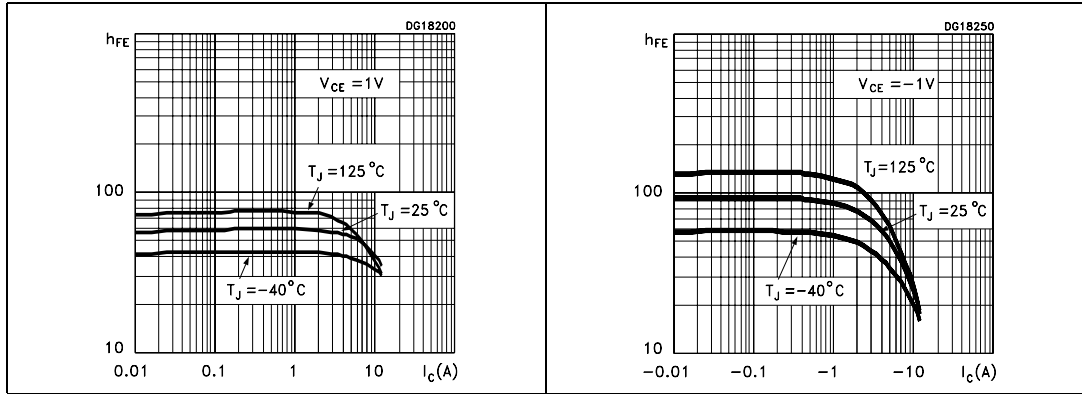

Figure 4. DC current gain for NPN type      Figure 5. DC current gain for PNP type

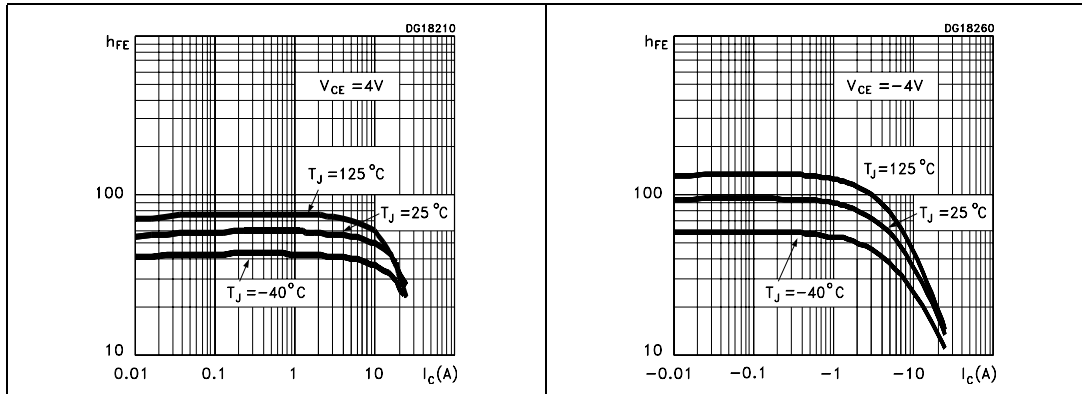
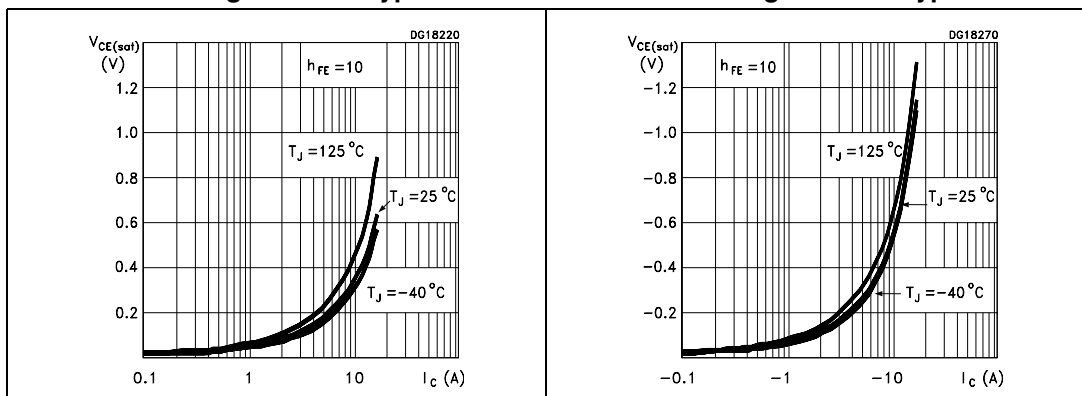
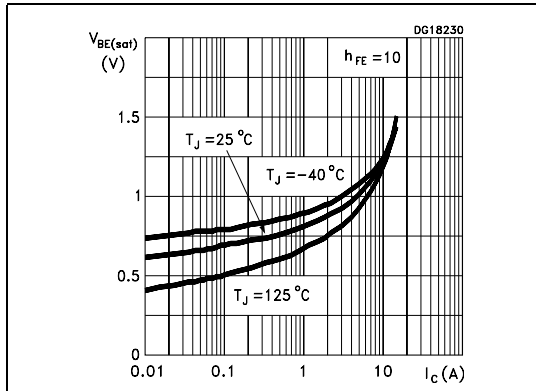

Figure 6. Collector-emitter saturation voltage for NPN type      Figure 7. Collector-emitter saturation voltage for PNP type



**Figure 8. Base-emitter saturation voltage for NPN type**



**Figure 9. Base-emitter saturation voltage for PNP type**

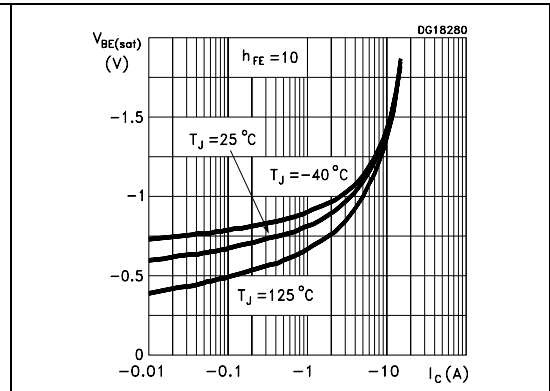

**Figure 10. Base-emitter on voltage for NPN type**

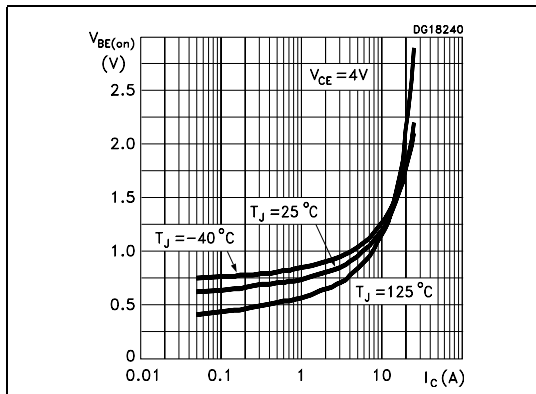

**Figure 11. Base-emitter on voltage for PNP type**

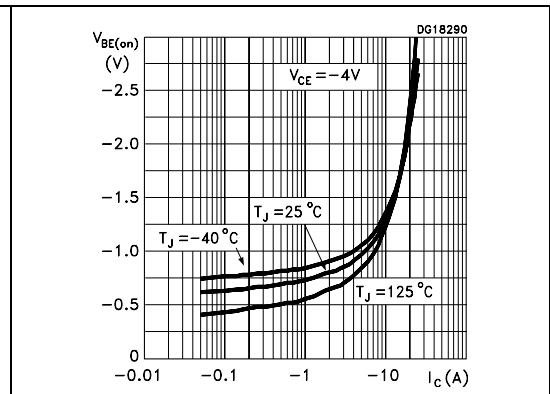

### 3 Package mechanical data

In order to meet environmental requirements, ST offers these devices in ECOPACK® packages. These packages have a Lead-free second level interconnect . The category of second level interconnect is marked on the package and on the inner box label, in compliance with JEDEC Standard JESD97. The maximum ratings related to soldering conditions are also marked on the inner box label. ECOPACK is an ST trademark. ECOPACK specifications are available at : [www.st.com](http://www.st.com)

## TO-247 Mechanical data

Dim.	mm.		
	Min.	Typ	Max.
A	4.85		5.15
A1	2.20		2.60
b	1.0		1.40
b1	2.0		2.40
b2	3.0		3.40
c	0.40		0.80
D	19.85		20.15
E	15.45		15.75
e		5.45	
L	14.20		14.80
L1	3.70		4.30
L2		18.50	
øP	3.55		3.65
øR	4.50		5.50
S		5.50	

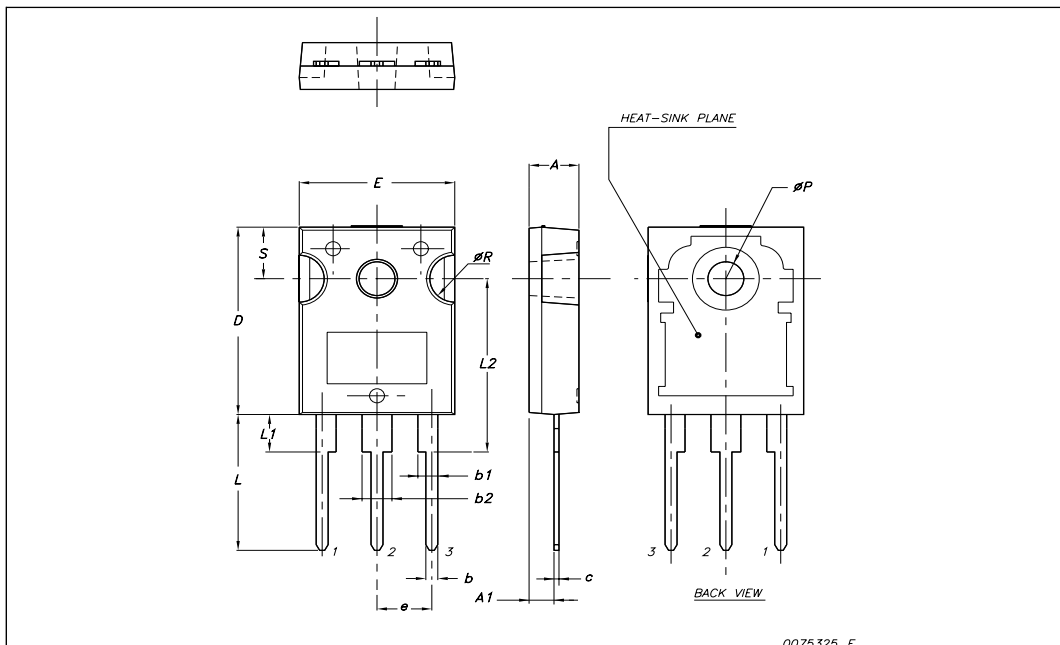

## 4 Revision history

**Table 5. Document revision history**

Date	Revision	Changes
07-Sep-2003	3	
07-Mar-2008	4	Package change from TO-218 to TO-247.
23-Sep-2008	5	Added figures <a href="#">2</a> , <a href="#">3</a> , <a href="#">4</a> , <a href="#">5</a> , <a href="#">6</a> , <a href="#">7</a> , <a href="#">8</a> , <a href="#">9</a> , <a href="#">10</a> , <a href="#">11</a> .