

NOTES:

1. EACH PART SHALL BE MARKED WITH U-92A/U & M9177/3-1.
2. PART SHALL BE ON QUALIFIED PRODUCT LIST FOR MIL-C-9177/3A.
3. CRIMPING TOOLS USE M22520/5-01 HAND TOOL W/CRIMP DIE M22520/5-29, M22520/5-35 OR M22520/5-55.
4. MATING CONNECTORS M9177/1-1 & M9177/2-1.

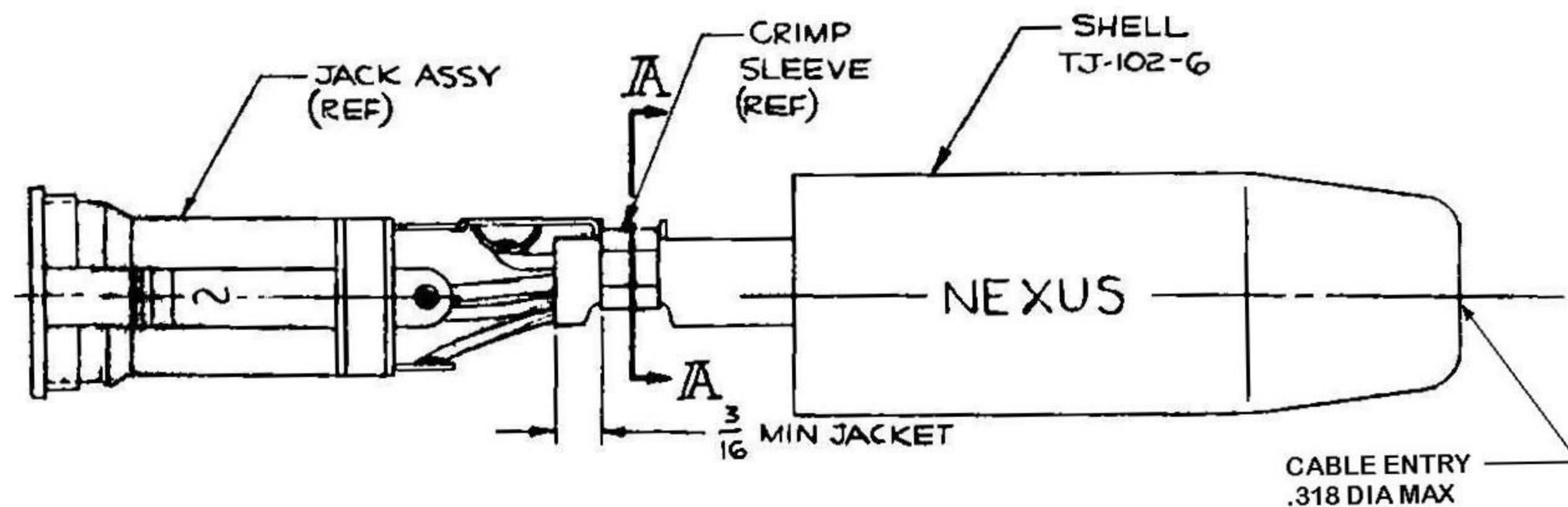

C TJ-102

CORD: WF-14/U (4 COND)
FOR USE WITH U-94A/U

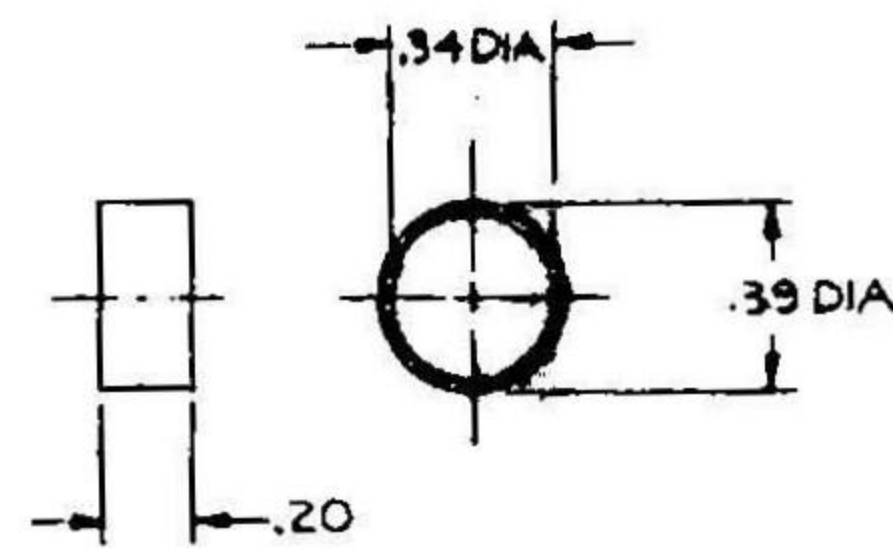
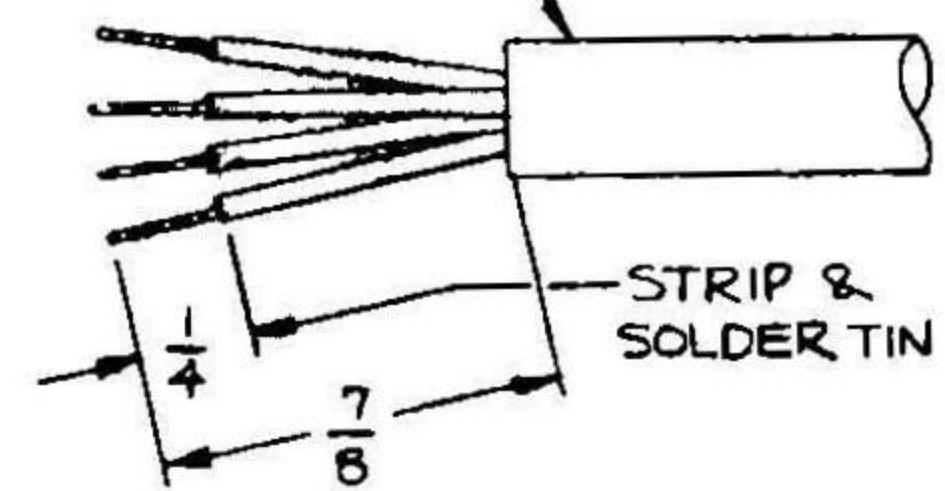

CRIMP SLEEVE
TP-102-20

DES. BY IDH	DATE 1/23/87	MATERIAL	NEXUS STAMFORD, CONN.
CHECKED BY		FINISH	
APP'D BY		WEIGHT	SCALE 2:1
UNLESS OTHERWISE SPECIFIED DIMENSIONS ARE IN INCHES TOLERANCES BY FRACTIONS DECIMALS ANGLES		TITLE TELEPHONE JACK	REV. NO. C TJ-102
DO NOT SCALE DWG.		SHEET	OF

A	1) SECT A-A CONFIG CHANGED	1-2-87
REVISION	DATE	CHG.