

# TJA1028

## LIN transceiver with integrated voltage regulator

Rev. 5 — 30 January 2023

Product data sheet

## 1 General description

---

The TJA1028 is a LIN 2.0/2.1/SAE J2602 and ISO 17987-4:2016 (12 V) compliant transceiver with an integrated low-drop voltage regulator. The voltage regulator can deliver up to 70 mA and is available in 3.3 V and 5.0 V variants. TJA1028 facilitates the development of compact nodes in Local Interconnect Network (LIN) bus systems. To support robust designs, the TJA1028 offers strong ElectroStatic Discharge (ESD) performance and can withstand high voltages on the LIN bus. In order to minimize current consumption, the TJA1028 supports a Sleep mode in which the LIN transceiver and the voltage regulator are powered down while still having wake-up capability via the LIN bus.

The TJA1028 comes in an SO8 package, and also in a 3 mm × 3 mm HVSON8 package that reduces the required board space by over 70 %. This feature can prove extremely valuable when board space is limited.

## 2 Features and benefits

---

- LIN 2.0/2.1/2.2 compliant
- SAE J2602 compliant
- ISO 17987-4:2016 (12 V) compliant (TJA1028A/B/C/D)
- Downward compatible with LIN 1.3
- Internal LIN responder termination resistor
- Voltage regulator offering 5 V or 3.3 V, 70 mA capability
- 2 % voltage regulator accuracy over specified temperature and supply ranges
- Voltage regulator output undervoltage detection with reset output
- Voltage regulator is short-circuit proof to ground
- Voltage regulator stable with ceramic, tantalum and aluminum electrolyte capacitors
- Robust ESD performance; ±8 kV according to IEC61000-4-2 for pins LIN and V<sub>BAT</sub>
- Pins LIN and V<sub>BAT</sub> protected against transients in the automotive environment (ISO 7637)
- Very low LIN bus leakage current of < 2 μA when battery not connected
- LIN pin short-circuit proof to battery and ground
- Transmit data (TXD) dominant time-out function
- Thermally protected
- Very low ElectroMagnetic Emission (EME)
- High ElectroMagnetic Immunity (EMI)
- Typical Standby mode current of 45 μA
- Typical Sleep mode current of 12 μA
- LIN bus wake-up function
- K-line compatible
- Available in SO8 and HVSON8 packages



- Leadless HVSON8 package (3.0 mm × 3.0 mm) with improved Automated Optical Inspection (AOI) capability
- Dark green product (halogen free and Restriction of Hazardous Substances (RoHS) compliant)

### 3 Quick reference data

Table 1. Quick reference data

Symbol	Parameter	Conditions	Min	Typ	Max	Unit
V <sub>BAT</sub>	battery supply voltage	limiting value with respect to GND	-0.3	-	+40	V
I <sub>BAT</sub>	battery supply current	Standby mode; V <sub>LIN</sub> = V <sub>BAT</sub>	-	45	59	μA
		Sleep mode; V <sub>LIN</sub> = V <sub>BAT</sub>	-	12	18	μA
		Normal mode; bus recessive;	-	850	1800	μA
		Normal mode; bus dominant;	-	2.0	4.5	mA
V <sub>LIN</sub>	voltage on pin LIN	limiting value with respect to GND	-40	-	+40	V
T <sub>vj</sub>	virtual junction temperature	limiting value	-40	-	+150	°C

### 4 Ordering information

Table 2. Ordering information

Type number	Regulator	Baud rate	Package		
			Name	Description	Version
TJA1028T/3V3/10	3.3 V	10.4 kBd	SO8	small plastic outline package; 8 leads; body width 3.9 mm	SOT96-1
TJA1028T/3V3/20	3.3 V	20 kBd			
TJA1028T/5V0/10	5 V	10.4 kBd			
TJA1028T/5V0/20	5 V	20 kBd			
TJA1028AT	3.3 V	10.4 kBd			
TJA1028BT	3.3 V	20 kBd			
TJA1028CT	5 V	10.4 kBd			
TJA1028DT	5 V	20 kBd			
TJA1028TK/3V3/10	3.3 V	10.4 kBd	HVSON8	plastic thermal enhanced very thin small outline package; no leads; 8 terminals; body 3 × 3 × 0.85 mm	SOT782-1
TJA1028TK/3V3/20	3.3 V	20 kBd			
TJA1028TK/5V0/10	5 V	10.4 kBd			
TJA1028TK/5V0/20	5 V	20 kBd			
TJA1028ATK	3.3 V	10.4 kBd			
TJA1028BTK	3.3 V	20 kBd			
TJA1028CTK	5 V	10.4 kBd			
TJA1028DTK	5 V	20 kBd			

5 Block diagram

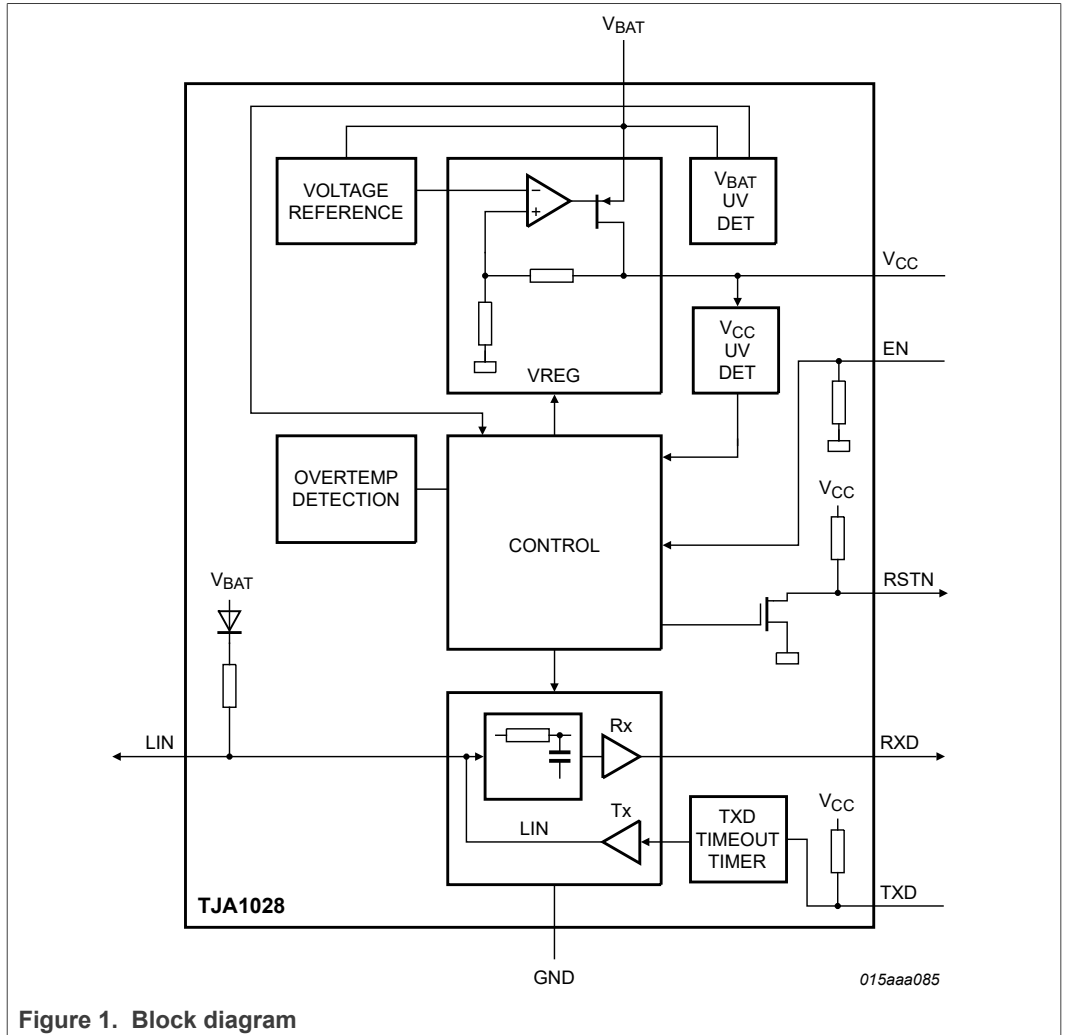
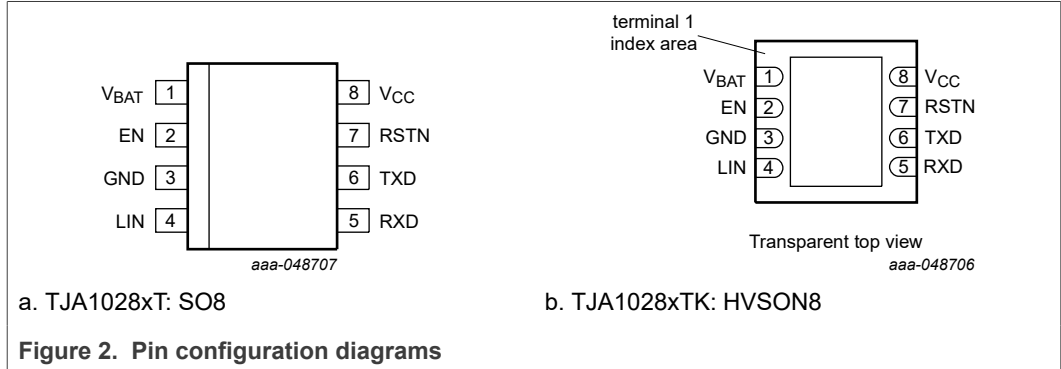

Figure 1. Block diagram

## 6 Pinning information

### 6.1 Pinning



### 6.2 Pin description

Table 3. Pin description

Symbol	Pin	Type <sup>[1]</sup>	Description
V <sub>BAT</sub>	1	P	battery supply for the TJA1028
EN	2	I	enable input
GND	3 [2]	G	ground
LIN	4	AIO	LIN bus line
RXD	5	O	LIN receive data output
TXD	6	I	LIN transmit data input
RSTN	7	I	reset output (active LOW)
V <sub>CC</sub>	8	P	voltage regulator output

[1] I: digital input; O: digital output; AIO: analog input/output; P: power supply; G: ground.

[2] HVSON8 package die supply ground is connected to both the GND pin and the exposed center pad. The GND pin must be soldered to board ground. For enhanced thermal and electrical performance, it is recommended that the exposed center pad also be soldered to board ground.

## 7 Functional description

The TJA1028 combines the functionality of a LIN transceiver and a voltage regulator in a single chip and offers wake-up by bus activity. The voltage regulator is designed to power the Electronic Control Unit (ECU) in the microcontroller and its peripherals.

The LIN transceiver is the interface between a LIN commander/responder protocol controller and the physical bus in a LIN network. According to the Open System Interconnect (OSI) model, these modules make up the LIN physical layer.

The TJA1028Tx/20, TJA1028Bx and TJA1028Dx variants are optimized for a transmission speed of 20 kBd. The TJA1028Tx/10, TJA1028Ax and TJA1028Cx variants are optimized for a transmission speed of 10.4 kBd. All variants achieve optimum ElectroMagnetic Compatibility (EMC) performance by wave shaping the LIN output.

7.1 LIN 2.x/SAE J2602 and ISO 17987-4:2016 (12 V) compliant

The TJA1028 is fully LIN 2.0, LIN 2.1, LIN 2.2, SAE J2602 and ISO 17987-4:2016 (12 V) compliant. Since the LIN physical layer is independent of higher OSI model layers (e.g. the LIN protocol), nodes containing an SO17987-4:2016 (12 V) compliant physical layer can be combined, without restriction, with LIN physical layer nodes that comply with earlier revisions (i.e. LIN 1.0, LIN 1.1, LIN 1.2, LIN 1.3, LIN 2.0, LIN 2.1, LIN 2.2 and LIN 2.2A).

7.2 Operating modes

The TJA1028 supports four operating modes: Normal, Standby, Sleep and Off. The operating modes, and the transitions between modes, are illustrated in Figure 3.

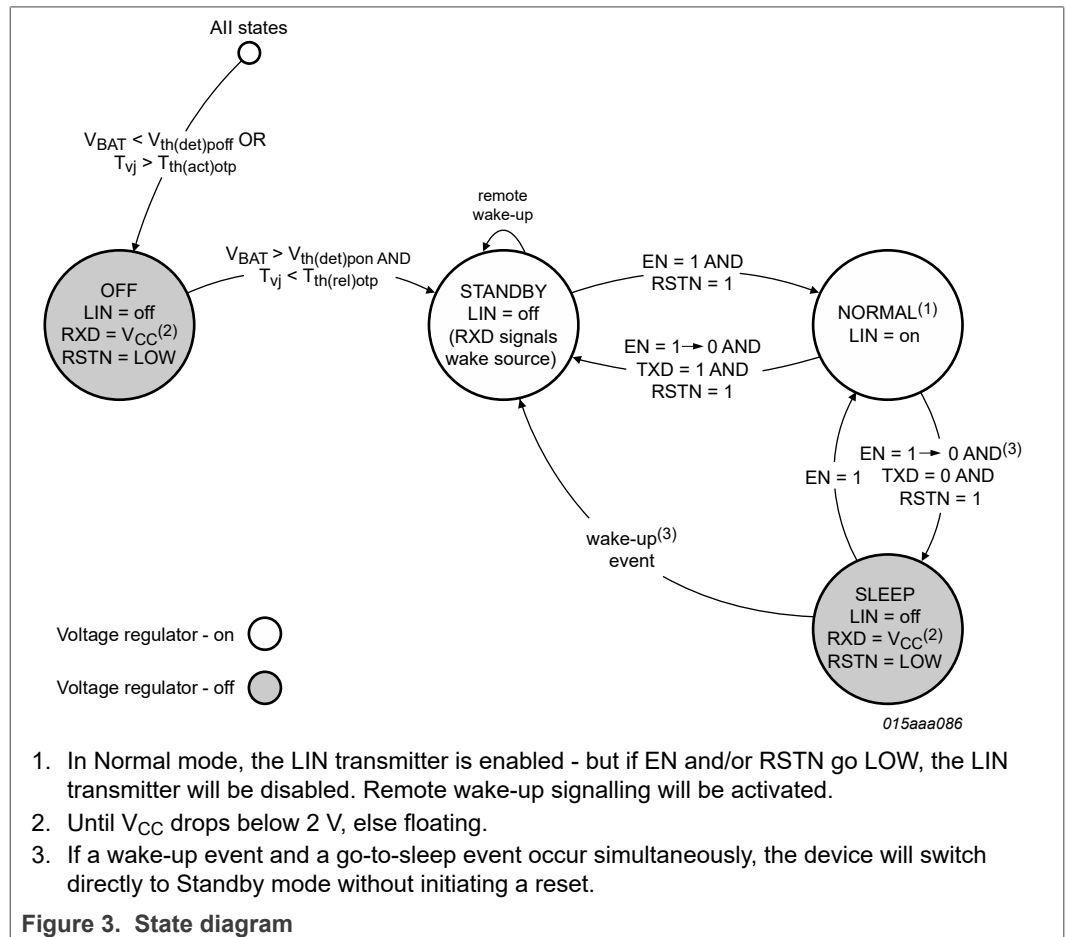

7.2.1 Off mode

The TJA1028 switches to Off mode from all other modes if the battery supply voltage drops below the power-off detection threshold (V<sub>th(det)poff</sub>) or the junction temperature exceeds the overtemperature protection activation threshold (T<sub>th(act)otp</sub>).

The voltage regulator and the LIN physical layer are disabled in Off mode, and pin RSTN is forced LOW.

### 7.2.2 Standby mode

Standby mode is a low-power mode that guarantees very low current consumption.

The TJA1028 switches from Off mode to Standby mode as soon as the battery supply voltage rises above the power-on detection threshold ( $V_{BAT} > V_{th(det)pon}$ ), provided the junction temperature is below the overtemperature protection release threshold ( $T_{vj} < T_{th(rel)otp}$ ).

The TJA1028 switches to Standby mode from Normal mode during the mode select window if TXD is HIGH and EN is LOW (see [Section 7.2.5](#)), provided RSTN = 1.

A remote wake-up event will trigger a transition to Standby mode from Sleep mode. The remote wake-up event will be signalled by a continuous LOW level on pin RXD.

In Standby mode, the voltage regulator is on, the LIN physical layer is disabled and remote wake-up detection is active. The wake-up source is indicated by the level on RXD (LOW indicates a remote wake-up).

### 7.2.3 Normal mode

If the EN pin is pulled HIGH while the TJA1028 is in Standby mode (with RSTN = 1) or Sleep mode, the device will enter Normal mode. The LIN physical layer and the voltage regulator are enabled in Normal mode.

#### 7.2.3.1 The LIN transceiver in Normal mode

The LIN transceiver is activated when the TJA1028 enters Normal mode.

In Normal mode, the transceiver can transmit and receive data via the LIN bus. The receiver detects data streams on the LIN pin and transfers them to the microcontroller via pin RXD. LIN recessive is represented by a HIGH level on RXD, LIN dominant by a LOW level.

The transmit data streams of the protocol controller at the TXD input are converted by the transmitter into bus signals with optimized slew rate and wave shaping to minimize EME. A LOW level at the TXD input is converted to a LIN dominant level while a HIGH level is converted to a LIN recessive level.

### 7.2.4 Sleep mode

Sleep mode features extremely low power consumption.

The TJA1028 switches to Sleep mode from Normal mode during the mode select window if TXD and EN are both LOW (see [Section 7.2.5](#)), provided RSTN = 1.

The voltage regulator and the LIN physical layer are disabled in Sleep mode. Pin RSTN is forced LOW. Remote wake-up detection is active.

### 7.2.5 Transition from Normal to Sleep or Standby mode

When EN is driven LOW in Normal mode, the TJA1028 disables the transmit path. The mode select window opens  $t_{msel(min)}$  after EN goes LOW, and remains open until  $t_{msel(max)}$  after EN goes LOW (see [Figure 4](#)).

The TXD pin is sampled in the mode select window. A transition to Standby mode is triggered if TXD is HIGH, or to Sleep mode if TXD is LOW.

To avoid complicated timing in the application, EN and TXD can be pulled LOW at the same time without having any effect on the LIN bus. In order to ensure that the remote wake-up time ( $t_{wake(dom)LIN}$ ) is not reset on a transition to Sleep mode, TXD should be pulled LOW at least  $t_{d(EN-TXD)}$  after EN goes LOW. This is guaranteed by design.

The user must ensure the appropriate level is present on pin TXD while the mode select window is open.

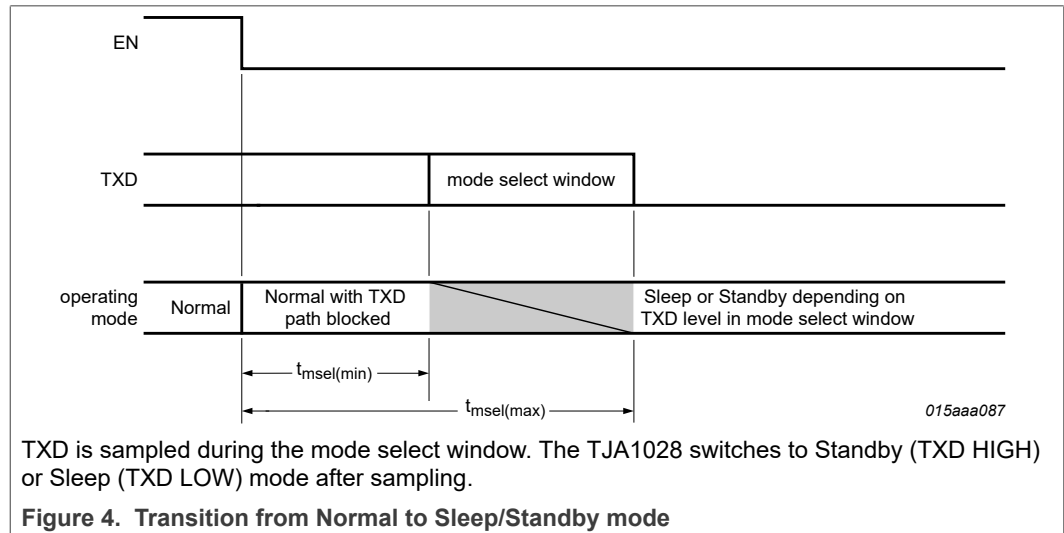

### 7.3 Power supplies

#### 7.3.1 Battery (pin V<sub>BAT</sub>)

The TJA1028 contains a single supply pin, V<sub>BAT</sub>. An external diode is needed in series to protect the device against negative voltages. The operating range is from 4.5 V to 28 V. The TJA1028 can handle voltages up to 40 V (max). If the voltage on pin V<sub>BAT</sub> falls below V<sub>th(det)poff</sub>, the TJA1028 switches to Off mode, shutting down the internal logic and the voltage regulator and disabling the LIN transmitter. The TJA1028 exits Off mode as soon as the voltage rises above V<sub>th(det)pon</sub>, provided the junction temperature is below T<sub>th(rel)otp</sub>.

#### 7.3.2 Voltage regulator (pin V<sub>CC</sub>)

The TJA1028 contains a voltage regulator supplied via pin V<sub>BAT</sub>, which delivers up to 70 mA. It is designed to supply the microcontroller and its periphery via pin V<sub>CC</sub>.

#### 7.3.3 Reset (pin RSTN)

The output voltage on pin V<sub>CC</sub> is monitored continuously and a system reset signal is generated (pin RSTN goes LOW) if an undervoltage event is detected ( $V_{CC} < V_{UVd}$  for  $t_{det(uv)(VCC)}$ ). Pin RSTN will go HIGH again once the voltage on V<sub>CC</sub> exceeds the undervoltage recovery threshold (V<sub>UVR</sub>) for t<sub>rst</sub>.

7.4 LIN transceiver

The transceiver is the interface between a LIN commander/responder protocol controller and the physical bus in a LIN network. It is primarily intended for in-vehicle sub-networks using baud rates from 2.4 kBd up to 20 kBd and is LIN 2.0/LIN 2.1/SAE J2602 compliant.

7.5 Remote wake-up

A remote wake-up is triggered by a falling edge on pin LIN, followed by LIN remaining LOW for at least  $t_{wake(dom)LIN}$ , followed by a rising edge on pin LIN (see Figure 5).

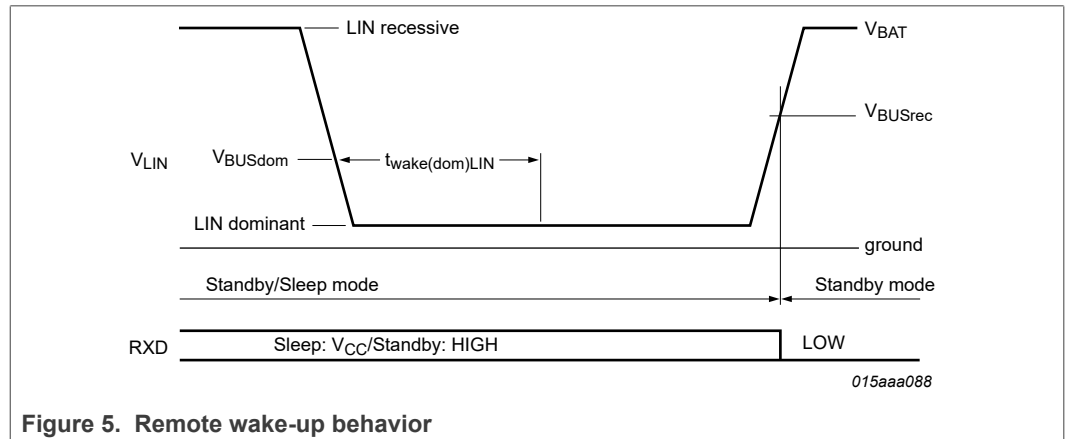

Figure 5. Remote wake-up behavior

The remote wake-up request is communicated to the microcontroller in Standby mode by a continuous LOW level on pin RXD.

Note that  $t_{wake(dom)LIN}$  is measured in Sleep and Standby modes, and in Normal mode if TXD is HIGH.

7.6 Fail-safe features

7.6.1 General fail-safe features

The following general fail-safe features have been implemented:

- An internal pull-up towards  $V_{CC}$  on pin TXD guarantees a recessive bus level if the pin is left floating by a bad solder joint or floating microcontroller port pin.
- The current in the transmitter output stage is limited in order to protect the transmitter against short circuits to pin  $V_{BAT}$ .
- A loss of power (pins  $V_{BAT}$  and GND) has no impact on the bus line or on the microcontroller. There will be no reverse currents from the bus.
- The LIN transmitter is automatically disabled when either EN or RSTN is LOW.
- After a transition to Normal mode, the LIN transmitter is only enabled if a recessive level is present on pin TXD.

7.6.2 TXD dominant time-out function

A TXD dominant time-out timer circuit prevents the bus line being driven to a permanent dominant state (blocking all network communications) if TXD is forced permanently LOW by a hardware or software application failure. The timer is triggered by a negative edge



on the TXD pin. If the pin remains LOW for longer than the TXD dominant time-out time ( $t_{to(dom)TXD}$ ), the transmitter is disabled, driving the bus line to a recessive state. The timer is reset by a positive edge on TXD.

### 7.6.3 Temperature protection

The temperature of the IC is monitored in Normal, Standby and Off modes. If the temperature is too high ( $T_{vj} > T_{th(act)otp}$ ), the TJA1028 will switch to Off mode (if in Standby or Normal modes). The voltage regulator and the LIN transmitter will be switched off and the RSTN pin driven LOW.

When the temperature falls below the overtemperature protection release threshold ( $T_{vj} < T_{th(rel)otp}$ ), the TJA1028 switches to Standby mode.

## 8 Limiting values

**Table 4. Limiting values**

In accordance with the Absolute Maximum Rating System (IEC 60134); all voltages are referenced to ground.

Symbol	Parameter	Conditions	Min	Max	Unit
V <sub>BAT</sub>	battery supply voltage <sup>[1]</sup>	DC; continuous	-0.3	+40	V
V <sub>x</sub>	voltage on pin x <sup>[1]</sup>	DC value			
		pin V <sub>CC</sub>	-0.3	+7	V
		pins TXD, RXD, RSTN and EN	-0.3	V <sub>CC</sub> + 0.3	V
		pin LIN with respect to GND	-40	+40	V
V <sub>trt</sub>	transient voltage	on pin V <sub>BAT</sub> via reverse polarity diode/capacitor; on pin LIN via 1 nF coupling capacitor <sup>[2]</sup>			
		pulse 1	-100	-	V
		pulse 2a	-	75	V
		pulse 3a	-150	-	V
		pulse 3b	-	100	V
V <sub>ESD</sub>	electrostatic discharge voltage	IEC 61000-4-2 (150 pF, 330 Ω discharge circuit) <sup>[3]</sup>			
		on pins LIN and V <sub>BAT</sub>	-8	+8	kV
		Human Body Model (HBM)			
		on any pin <sup>[4]</sup>	-2	+2	kV
		on pins LIN and V <sub>BAT</sub> <sup>[5]</sup>	-8	+8	kV
		Machine Model (MM); 200 pF, 0.75 μH, 10 Ω <sup>[6]</sup>	-250	+250	V
		on any pin			
		Charged Device Model (CDM) <sup>[7]</sup>			
		on corner pins	-750	+750	V
on any other pin	-500	+500	V		
T <sub>vj</sub>	virtual junction temperature	<sup>[8]</sup>	-40	+150	°C
T <sub>stg</sub>	storage temperature	<sup>[9]</sup>	-55	+150	°C

- [1] The device can sustain voltages up to the specified values over the product lifetime, provided applied voltages (including transients) never exceed these values.
- [2] Verified by an external test house according to LIN Conformance Test Specification Package for LIN 2.1; parameters for standard pulses defined in ISO 7637.
- [3] Verified by an external test house according to LIN Conformance Test Specification Package for LIN 2.1.
- [4] According to AEC-Q100-002.
- [5] Pins stressed to reference group containing all ground and supply pins, emulating the application circuit (xx). HBM pulse as specified in AEC-Q100-002 used.
- [6] According to AEC-Q100-003.
- [7] According to AEC-Q100-011.
- [8] In accordance with IEC 60747-1. An alternative definition of virtual junction temperature is:  $T_{vj} = T_{amb} + P \times R_{th(vj-a)}$ , where  $R_{th(vj-a)}$  is a fixed value to be used for the calculation of  $T_{vj}$ . The rating for  $T_{vj}$  limits the allowable combinations of power dissipation (P) and ambient temperature ( $T_{amb}$ ).
- [9] T<sub>stg</sub> in application according to IEC61360-4. For component transport and storage conditions, see instead IEC61760-2.

## 9 Thermal characteristics

**Table 5. Thermal characteristics**

Value determined for free convection conditions on a JEDEC 2S2P board.

Symbol	Parameter	Conditions <sup>[1]</sup>	Typ	Unit
R <sub>th(j-a)</sub>	thermal resistance from junction to ambient	SO8 package; in free air	88	K/W
		HVSON8 package; in free air	59	K/W
R <sub>th(j-c)</sub>	thermal resistance from junction to case	HVSON8 package; in free air	21	K/W
Ψ <sub>j-top</sub>	thermal characterization parameter from junction to top of package	SO8 package; in free air	17	K/W
		HVSON8 package; in free air	10	K/W

[1] According to JEDEC JESD51-2, JESD51-5 and JESD51-7 at natural convection on 2s2p board. Board with two inner copper layers (thickness: 35 μm) and thermal via array under the exposed pad connected to the first inner copper layer (thickness: 70 μm).

## 10 Static characteristics

**Table 6. Static characteristics**

V<sub>BAT</sub> = 5.5 V to 28 V; T<sub>vj</sub> = -40 °C to +150 °C; R<sub>L(LIN-VBAT)</sub> = 500 Ω; typical values are given at V<sub>BAT</sub> = 12 V unless otherwise specified; all voltages are defined with respect to ground; positive currents flow into the IC.<sup>[1]</sup>

Symbol	Parameter	Conditions	Min	Typ	Max	Unit
<b>Supply; pin V<sub>BAT</sub></b>						
I <sub>BAT</sub>	battery supply current	Standby mode; V <sub>LIN</sub> = V <sub>BAT</sub>	-	45	59	μA
		Sleep mode; V <sub>LIN</sub> = V <sub>BAT</sub>	-	12	18	μA
		Normal mode; bus recessive; V <sub>LIN</sub> = V <sub>BAT</sub> ; V <sub>RXD</sub> = V <sub>CC</sub> ; V <sub>RSTN</sub> = HIGH	-	850	1800	μA
		Normal mode; bus dominant; V <sub>BAT</sub> = 12 V; V <sub>TXD</sub> = 0 V; V <sub>RSTN</sub> = HIGH	-	2.0	4.5	mA
V <sub>th(det)pon</sub>	power-on detection threshold voltage		-	-	5.25	V
V <sub>th(det)poff</sub>	power-off detection threshold voltage		3	-	4.2	V
V <sub>hys(det)pon</sub>	power-on detection hysteresis voltage	V <sub>BAT</sub> = 2 V to 28 V	50	-	-	mV
<b>Supply; pin V<sub>CC</sub></b>						
V <sub>CC</sub>	supply voltage	V <sub>CC(nom)</sub> = 5 V; I <sub>VCC</sub> = -70 mA to 0 mA	4.9	5	5.1	V
		V <sub>CC(nom)</sub> = 3.3 V; V <sub>BAT</sub> = 4.5 V to 28 V; I <sub>VCC</sub> = -70 mA to 0 mA	3.234	3.3	3.366	V
I <sub>Olim</sub>	output current limit	V <sub>CC</sub> = 0 V to 5.5 V	-250	-	-70	mA
V <sub>uvd</sub>	undervoltage detection voltage	V <sub>CC(nom)</sub> = 5 V	4.5	-	4.75	V
		V <sub>CC(nom)</sub> = 3.3 V	2.97	-	3.135	V
V <sub>uvr</sub>	undervoltage recovery voltage	V <sub>CC(nom)</sub> = 5 V	4.6	-	4.9	V
		V <sub>CC(nom)</sub> = 3.3 V	3.036	-	3.234	V

**Table 6. Static characteristics...continued**

$V_{BAT} = 5.5\text{ V to }28\text{ V}$ ;  $T_{vj} = -40\text{ }^{\circ}\text{C to }+150\text{ }^{\circ}\text{C}$ ;  $R_{L(LIN-VBAT)} = 500\ \Omega$ ; typical values are given at  $V_{BAT} = 12\text{ V}$  unless otherwise specified; all voltages are defined with respect to ground; positive currents flow into the IC.<sup>[1]</sup>

Symbol	Parameter	Conditions	Min	Typ	Max	Unit
$R_{(VBAT-VCC)}$	resistance between pin $V_{BAT}$ and pin $V_{CC}$	$V_{CC(nom)} = 5\text{ V}$ ; $V_{BAT} = 4.5\text{ V to }5.5\text{ V}$ ; <sup>[2]</sup> $I_{VCC} = -70\text{ mA to }-5\text{ mA}$ ; regulator in saturation <sup>[3]</sup>				
		$T_{vj} = 85\text{ }^{\circ}\text{C}$	-	-	7	$\Omega$
		$T_{vj} = 150\text{ }^{\circ}\text{C}$	-	-	9	$\Omega$
$C_o$	output capacitance	equivalent series resistance < $5\ \Omega$ <sup>[3]</sup>	1.8	10	-	$\mu\text{F}$
<b>LIN transmit data input; pin TXD</b>						
$V_{th(sw)}$	switching threshold voltage	$V_{CC} = 2.97\text{ V to }5.5\text{ V}$	$0.3 \times V_{CC}$	-	$0.7 \times V_{CC}$	V
$V_{hys(i)}$	input hysteresis voltage	$V_{CC} = 2.97\text{ V to }5.5\text{ V}$	200	-	-	mV
$R_{pu}$	pull-up resistance		5	12	25	k $\Omega$
<b>LIN receive data output; pin RXD</b>						
$I_{OH}$	HIGH-level output current	Normal mode; $V_{LIN} = V_{BAT}$ ; $V_{RXD} = V_{CC} - 0.4\text{ V}$	-	-	-0.4	mA
$I_{OL}$	LOW-level output current	Normal mode; $V_{LIN} = \text{GND}$ ; $V_{RXD} = 0.4\text{ V}$	0.4	-	-	mA
<b>Enable input; pin EN</b>						
$V_{th(sw)}$	switching threshold voltage		0.8	-	2	V
$R_{pd}$	pull-down resistance		50	130	400	k $\Omega$
<b>Reset output; pin RSTN</b>						
$R_{pu}$	pull-up resistance	$V_{RSTN} = V_{CC} - 0.4\text{ V}$ ; $V_{CC} = 2.97\text{ V to }5.5\text{ V}$	3	-	12	k $\Omega$
$I_{OL}$	LOW-level output current	$V_{RSTN} = 0.4\text{ V}$ ; $V_{CC} = 2.97\text{ V to }5.5\text{ V}$ ; $-40\text{ }^{\circ}\text{C} < T_{vj} < 195\text{ }^{\circ}\text{C}$	3.2	-	40	mA
$V_{OL}$	LOW-level output voltage	$V_{CC} = 2.5\text{ V to }5.5\text{ V}$ ; $-40\text{ }^{\circ}\text{C} < T_{vj} < 195\text{ }^{\circ}\text{C}$	-	-	0.5	V
$V_{OH}$	HIGH-level output voltage	$-40\text{ }^{\circ}\text{C} < T_{vj} < 195\text{ }^{\circ}\text{C}$	$0.8 \times V_{CC}$	-	$V_{CC} + 0.3$	V
<b>LIN bus line; pin LIN</b>						
$I_{BUS\_LIM}$	current limitation for driver dominant state	$V_{BAT} = V_{LIN} = 18\text{ V}$ ; $V_{TXD} = 0\text{ V}$	40	-	100	mA
$I_{BUS\_PAS\_rec}$	receiver recessive input leakage current	$V_{LIN} = 18\text{ V}$ ; $V_{BAT} = 5.5\text{ V}$ ; $V_{TXD} = V_{CC}$	-	-	2	$\mu\text{A}$
$I_{BUS\_PAS\_dom}$	receiver dominant input leakage current including pull-up resistor	Normal mode; $V_{TXD} = V_{CC}$ ; $V_{LIN} = 0\text{ V}$ ; $V_{BAT} = 12\text{ V}$	-600	-	-	$\mu\text{A}$
$I_{BUS\_NO\_GND}$	loss-of-ground bus current	$V_{BAT} = 18\text{ V}$ ; $V_{LIN} = 0\text{ V}$	-750	-	+10	$\mu\text{A}$
$I_{BUS\_NO\_BAT}$	loss-of-battery bus current	$V_{BAT} = 0\text{ V}$ ; $V_{LIN} = 18\text{ V}$	-	-	2	$\mu\text{A}$

**Table 6. Static characteristics...continued**

$V_{BAT} = 5.5\text{ V to }28\text{ V}$ ;  $T_{vj} = -40\text{ °C to }+150\text{ °C}$ ;  $R_{L(LIN-VBAT)} = 500\ \Omega$ ; typical values are given at  $V_{BAT} = 12\text{ V}$  unless otherwise specified; all voltages are defined with respect to ground; positive currents flow into the IC.<sup>[1]</sup>

Symbol	Parameter	Conditions	Min	Typ	Max	Unit
$V_{BUSrec}$	receiver recessive state	$V_{BAT} = 5.5\text{ V to }18\text{ V}$	$0.6 \times V_{BAT}$	-	-	V
$V_{BUSdom}$	receiver dominant state	$V_{BAT} = 5.5\text{ V to }18\text{ V}$	-	-	$0.4 \times V_{BAT}$	V
$V_{BUS\_CNT}$	receiver center voltage	$V_{BAT} = 5.5\text{ V to }18\text{ V}$ ; $V_{BUS\_CNT} = (V_{BUSdom} + V_{BUSrec}) / 2$	$0.475 \times V_{BAT}$	$0.5 \times V_{BAT}$	$0.525 \times V_{BAT}$	V
$V_{HYS}$	receiver hysteresis voltage	$V_{BAT} = 5.5\text{ V to }18\text{ V}$ ; $V_{HYS} = V_{BUSrec} - V_{BUSdom}$	$0.05 \times V_{BAT}$	$0.15 \times V_{BAT}$	$0.175 \times V_{BAT}$	V
$V_{SerDiode}$	voltage drop at the serial diode	in pull-up path with $R_{res}$ ; $I_{SerDiode} = 0.9\text{ mA}$	0.4	-	1.0	V
$C_{LIN}$	capacitance on pin LIN	with respect to GND	-	-	30	pF
$V_{O(dom)}$	dominant output voltage	Normal mode; $V_{TXD} = 0\text{ V}$ ; $V_{BAT} = 7\text{ V}$	-	-	1.4	V
		Normal mode; $V_{TXD} = 0\text{ V}$ ; $V_{BAT} = 18\text{ V}$	-	-	2.0	V
$R_{res}$	responder resistance	between pin LIN and $V_{BAT}$ ; $V_{LIN} = 0\text{ V}$ ; $V_{BAT} = 12\text{ V}$	20	30	60	k $\Omega$
<b>Temperature protection</b>						
$T_{th(act)otp}$	overtemperature protection activation threshold temperature		165	180	195	°C
$T_{th(rel)otp}$	overtemperature protection release threshold temperature		126	138	150	°C

[1] All parameters are guaranteed over the virtual junction temperature range by design. Factory testing uses correlated test conditions to cover the specified temperature and power supply voltage range.  
 [2] See [Figure 1](#) and [Figure 6](#).  
 [3] Not tested in production; guaranteed by design.  
 [4] See [Figure 8](#).

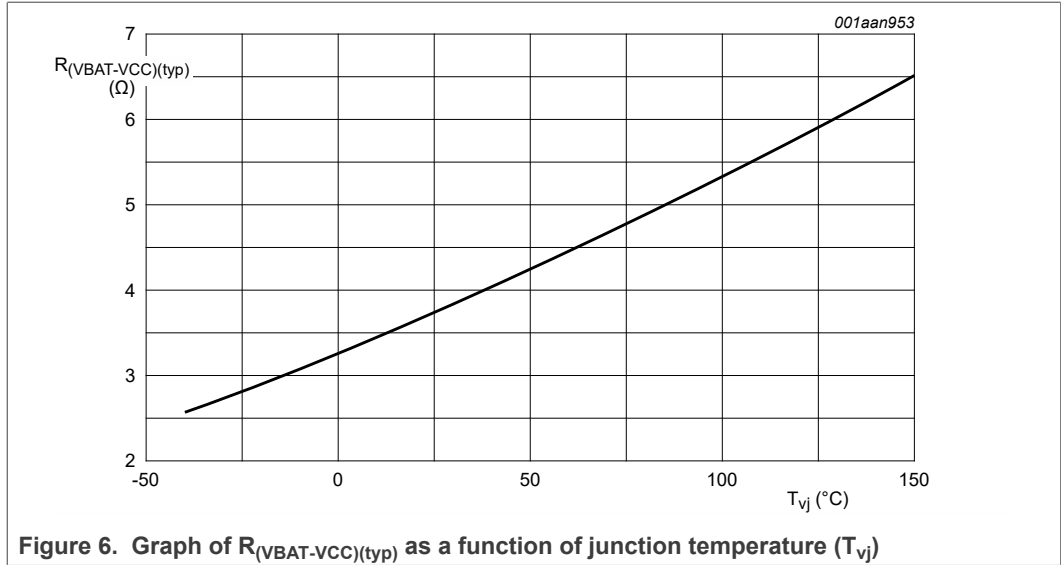

## 11 Dynamic characteristics

Table 7. Dynamic characteristics

$V_{BAT} = 5.5\text{ V to }18\text{ V}$ ;  $T_{vj} = -40\text{ }^{\circ}\text{C to }+150\text{ }^{\circ}\text{C}$ ;  $R_{L(LIN-VBAT)} = 500\text{ }\Omega$ ; typical values are given at  $V_{BAT} = 12\text{ V}$  unless otherwise specified; all voltages are defined with respect to ground.<sup>[1]</sup>

Symbol	Parameter	Conditions	Min	Typ	Max	Unit
<b>Duty cycles</b>						
$\delta 1$	duty cycle 1	$V_{th(rec)(max)} = 0.744V_{BAT}$ ; [2] $V_{th(dom)(max)} = 0.581V_{BAT}$ ; [3] $t_{bit} = 50\text{ }\mu\text{s}$ ; [4] $V_{BAT} = 7\text{ V to }18\text{ V}$ [5]	0.396	-	-	
		$V_{th(rec)(max)} = 0.76V_{BAT}$ ; [2] $V_{th(dom)(max)} = 0.593V_{BAT}$ ; [3] $t_{bit} = 50\text{ }\mu\text{s}$ ; [4] $V_{BAT} = 5.5\text{ V to }7.0\text{ V}$ [5]	0.396	-	-	
$\delta 2$	duty cycle 2	$V_{th(rec)(min)} = 0.422V_{BAT}$ ; [2] $V_{th(dom)(min)} = 0.284V_{BAT}$ ; [4] $t_{bit} = 50\text{ }\mu\text{s}$ ; [5] $V_{BAT} = 7.6\text{ V to }18\text{ V}$ [6]	-	-	0.581	
		$V_{th(rec)(min)} = 0.41V_{BAT}$ ; [2] $V_{th(dom)(min)} = 0.275V_{BAT}$ ; [4] $t_{bit} = 50\text{ }\mu\text{s}$ ; [5] $V_{BAT} = 6.1\text{ V to }7.6\text{ V}$ [6]	-	-	0.581	
$\delta 3$	duty cycle 3	$V_{th(rec)(max)} = 0.778V_{BAT}$ ; [3] $V_{th(dom)(max)} = 0.616V_{BAT}$ ; [4] $t_{bit} = 96\text{ }\mu\text{s}$ ; [5] $V_{BAT} = 7\text{ V to }18\text{ V}$	0.417	-	-	
		$V_{th(rec)(max)} = 0.797V_{BAT}$ ; [3] $V_{th(dom)(max)} = 0.630V_{BAT}$ ; [4] $t_{bit} = 96\text{ }\mu\text{s}$ ; [5] $V_{BAT} = 5.5\text{ V to }7\text{ V}$	0.417	-	-	

Table 7. Dynamic characteristics...continued

$V_{BAT} = 5.5\text{ V to }18\text{ V}$ ;  $T_{vj} = -40\text{ }^{\circ}\text{C to }+150\text{ }^{\circ}\text{C}$ ;  $R_{L(LIN-VBAT)} = 500\ \Omega$ ; typical values are given at  $V_{BAT} = 12\text{ V}$  unless otherwise specified; all voltages are defined with respect to ground.<sup>[1]</sup>

Symbol	Parameter	Conditions	Min	Typ	Max	Unit
$\delta 4$	duty cycle 4	$V_{th(rec)(min)} = 0.389V_{BAT}$ ; <sup>[4]</sup> $V_{th(dom)(min)} = 0.251V_{BAT}$ ; <sup>[5]</sup> $t_{bit} = 96\ \mu\text{s}$ ; <sup>[6]</sup> $V_{BAT} = 7.6\text{ V to }18\text{ V}$	-	-	0.590	
		$V_{th(rec)(min)} = 0.378V_{BAT}$ ; <sup>[4]</sup> $V_{th(dom)(min)} = 0.242V_{BAT}$ ; <sup>[5]</sup> $t_{bit} = 96\ \mu\text{s}$ ; <sup>[6]</sup> $V_{BAT} = 6.1\text{ V to }7.6\text{ V}$	-	-	0.590	
<b>Timing characteristics</b>						
$t_{rx\_pd}$	receiver propagation delay	rising and falling; $C_{RXD} = 20\text{ pF}$	-	-	6	$\mu\text{s}$
$t_{rx\_sym}$	receiver propagation delay symmetry	$C_{RXD} = 20\text{ pF}$	-2	-	+2	$\mu\text{s}$
$t_{wake(dom)LIN}$	LIN dominant wake-up time	Sleep mode	30	80	150	$\mu\text{s}$
$t_{to(dom)TXD}$	TXD dominant time-out time	$V_{TXD} = 0\text{ V}$	6	-	20	ms
$t_{mSel}$	mode select time		3	-	20	$\mu\text{s}$
$t_{d(EN-TXD)}$	delay time from EN to TXD		<sup>[7]</sup> 0	-	1	$\mu\text{s}$
$t_{det(uv)(VCC)}$	undervoltage detection time on pin $V_{CC}$	$C_{RSTN} = 20\text{ pF}$	1	-	15	$\mu\text{s}$
<b>Reset output; pin RSTN</b>						
$t_{rst}$	reset time		2	-	8	ms

[1] All parameters are guaranteed over the virtual junction temperature range by design. Factory testing uses correlated test conditions to cover the specified temperature and power supply voltage ranges.

[2] Not applicable to the low slope versions (TJA1028T/xxx/10 and TJA1028TK/xxx/10) of the TJA1028.

[3]  $\delta 1, \delta 3 = \frac{t_{bus(rec)(min)}}{2 \times t_{bit}}$ . Variable  $t_{bus(rec)(min)}$  is illustrated in the LIN timing diagram in Figure 8.

[4] Bus load conditions are:  $C_{BUS} = 1\text{ nF}$  and  $R_{BUS} = 1\text{ k}\Omega$ ;  $C_{BUS} = 6.8\text{ nF}$  and  $R_{BUS} = 660\ \Omega$ ;  $C_{BUS} = 10\text{ nF}$  and  $R_{BUS} = 500\ \Omega$ .

[5] For  $V_{BAT} > 18\text{ V}$ , the LIN transmitter might be suppressed. If TXD is HIGH then the LIN transmitter output is recessive.

[6]  $\delta 2, \delta 4 = \frac{t_{bus(rec)(max)}}{2 \times t_{bit}}$ . Variable  $t_{bus(rec)(max)}$  is illustrated in the LIN timing diagram in Figure 8.

[7] Not tested in production; guaranteed by design.

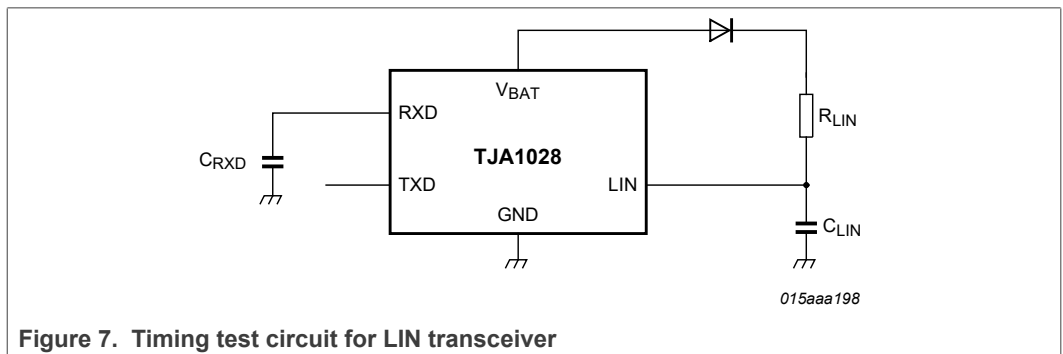

Figure 7. Timing test circuit for LIN transceiver

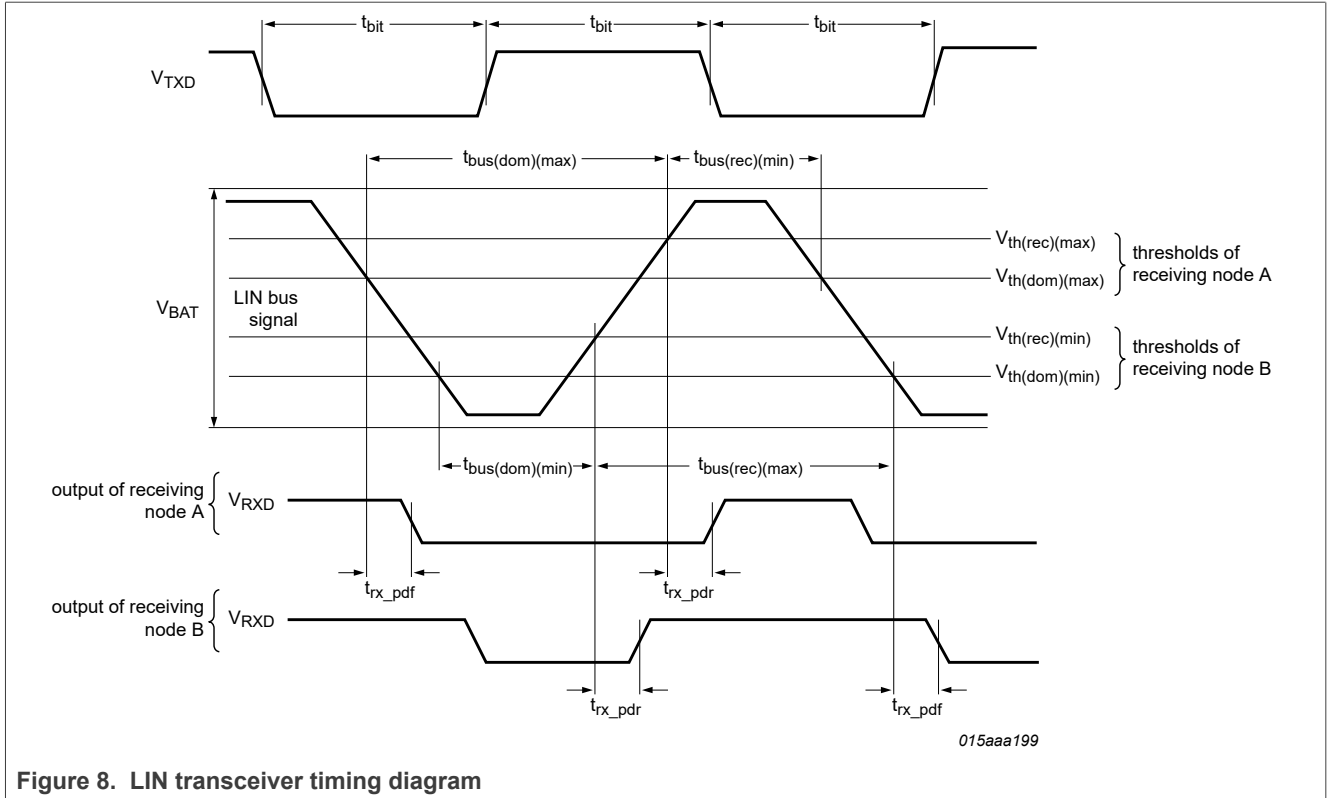

Figure 8. LIN transceiver timing diagram

## 12 Application information

The minimum external circuitry needed with the TJA1028 is shown in [Figure 9](#). See the Application Hints ([Section 12.1](#)) for further information about external components and PCB layout

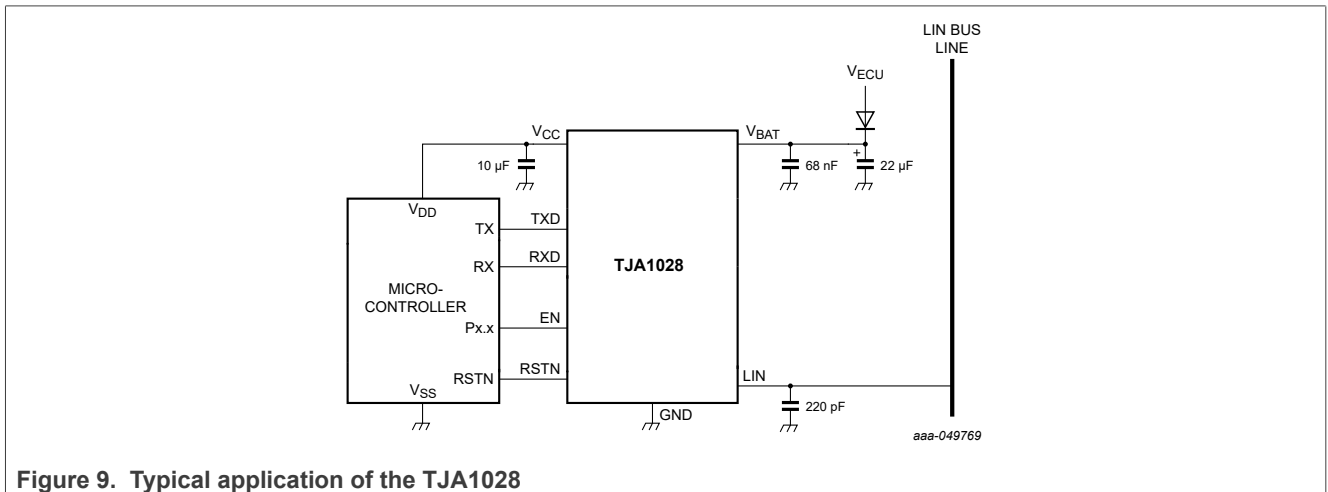

Figure 9. Typical application of the TJA1028



## 12.1 Application hints

Further information on the application of the TJA1028 can be found in NXP application hints *AH1103 Application Hints TJA1028 LIN transceiver with integrated voltage regulator*.

## 13 Quality information

---

This product has been qualified in accordance with the Automotive Electronics Council (AEC) standard *Q100 Rev-G - Failure mechanism based stress test qualification for integrated circuits*, and is suitable for use in automotive applications.

14 Package outline

SO8: plastic small outline package; 8 leads; body width 3.9 mm

SOT96-1

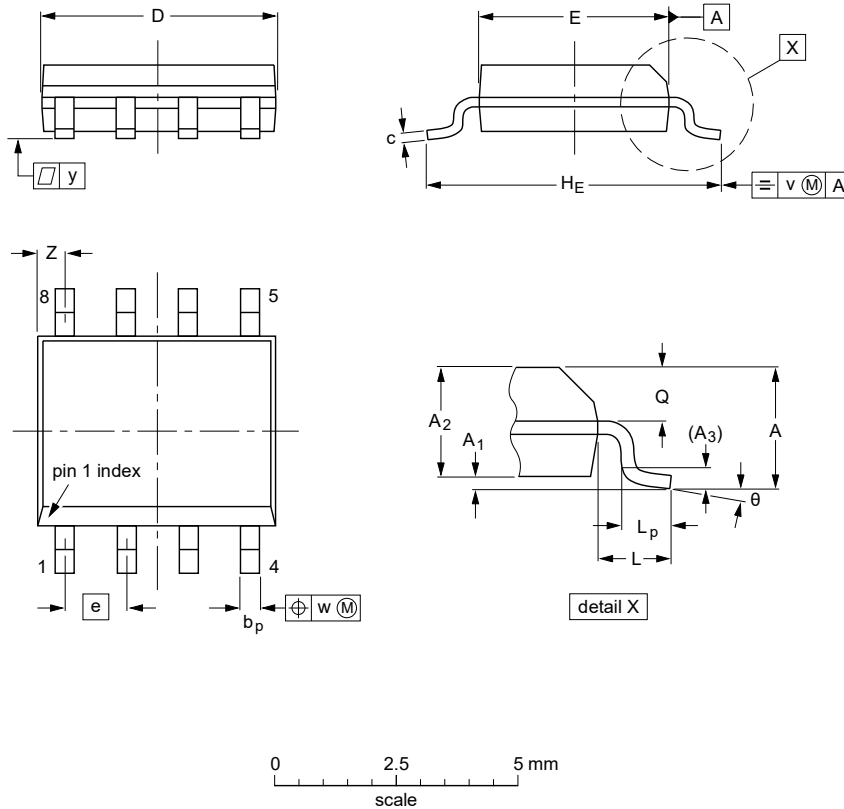

DIMENSIONS (inch dimensions are derived from the original mm dimensions)

UNIT	A max.	A <sub>1</sub>	A <sub>2</sub>	A <sub>3</sub>	b <sub>p</sub>	c	D <sup>(1)</sup>	E <sup>(2)</sup>	e	H <sub>E</sub>	L	L <sub>p</sub>	Q	v	w	y	Z <sup>(1)</sup>	θ
mm	1.75	0.25 0.10	1.45 1.25	0.25	0.49 0.36	0.25 0.19	5.0 4.8	4.0 3.8	1.27	6.2 5.8	1.05	1.0 0.4	0.7 0.6	0.25	0.25	0.1	0.7 0.3	8° 0°
inches	0.069	0.010 0.004	0.057 0.049	0.01	0.019 0.014	0.0100 0.0075	0.20 0.19	0.16 0.15	0.05	0.244 0.228	0.041	0.039 0.016	0.028 0.024	0.01	0.01	0.004	0.028 0.012	

Notes

1. Plastic or metal protrusions of 0.15 mm (0.006 inch) maximum per side are not included.
2. Plastic or metal protrusions of 0.25 mm (0.01 inch) maximum per side are not included.

OUTLINE VERSION	REFERENCES			EUROPEAN PROJECTION	ISSUE DATE
	IEC	JEDEC	JEITA		
SOT96-1	076E03	MS-012			99-12-27 03-02-18

Figure 10. Package outline SOT96-1 (SO8)

HVSON8: plastic thermal enhanced very thin small outline package; no leads;  
8 terminals; body 3 x 3 x 0.85 mm

SOT782-1

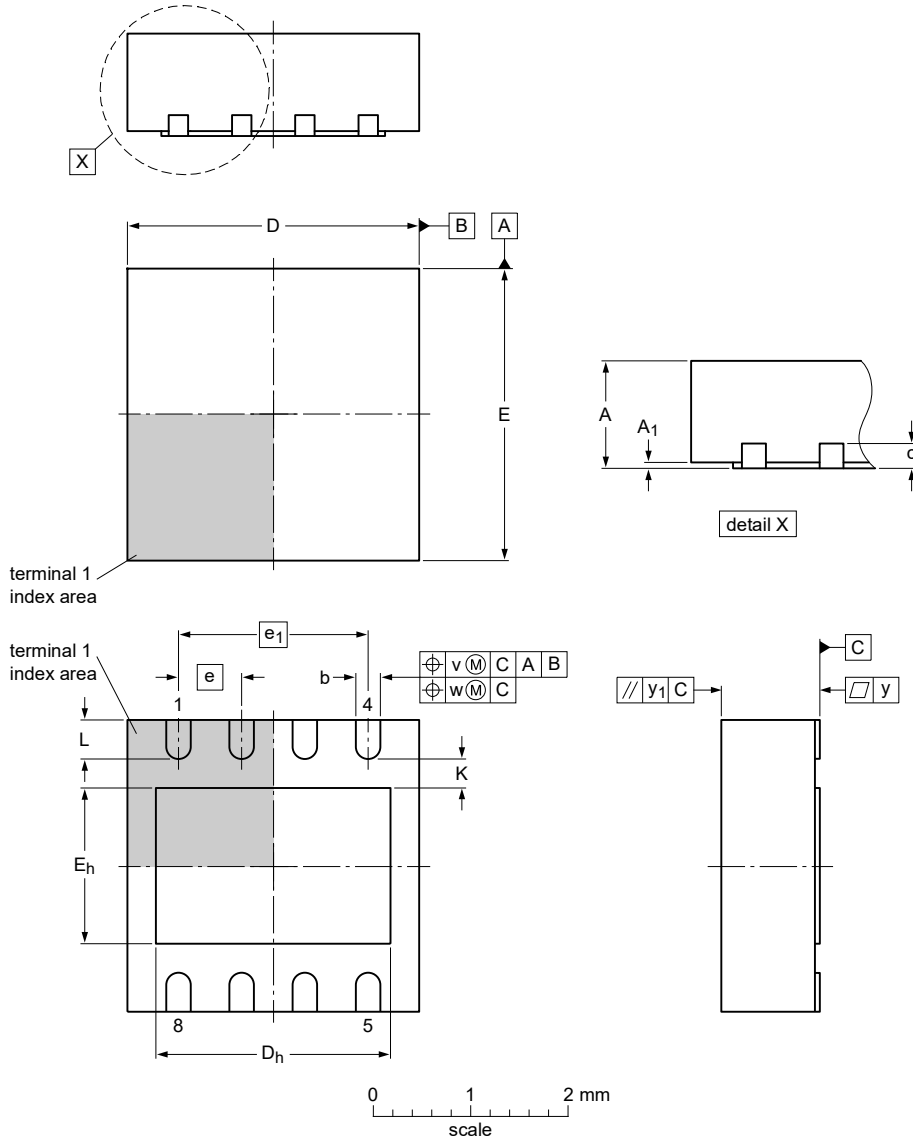

Dimensions

Unit <sup>(1)</sup>	A	A <sub>1</sub>	b	c	D	D <sub>h</sub>	E	E <sub>h</sub>	e	e <sub>1</sub>	K	L	v	w	y	y <sub>1</sub>
max	1.00	0.05	0.35		3.10	2.45	3.10	1.65			0.35	0.45				
mm nom	0.85	0.03	0.30	0.2	3.00	2.40	3.00	1.60	0.65	1.95	0.30	0.40	0.1	0.05	0.05	0.1
min	0.80	0.00	0.25		2.90	2.35	2.90	1.55			0.25	0.35				

Note

1. Plastic or metal protrusions of 0.075 maximum per side are not included.

sot782-1\_po

Outline version	References				European projection	Issue date
	IEC	JEDEC	JEITA			
SOT782-1	---	MO-229	---			09-08-25 09-08-28

Figure 11. Package outline SOT782-1 (HVSON8)

## 15 Handling information

All input and output pins are protected against ElectroStatic Discharge (ESD) under normal handling. When handling ensure that the appropriate precautions are taken as described in *JESD625-A* or equivalent standards.

## 16 Soldering of SMD packages

This text provides a very brief insight into a complex technology. A more in-depth account of soldering ICs can be found in Application Note *AN10365 "Surface mount reflow soldering description"*.

### 16.1 Introduction to soldering

Soldering is one of the most common methods through which packages are attached to Printed Circuit Boards (PCBs), to form electrical circuits. The soldered joint provides both the mechanical and the electrical connection. There is no single soldering method that is ideal for all IC packages. Wave soldering is often preferred when through-hole and Surface Mount Devices (SMDs) are mixed on one printed wiring board; however, it is not suitable for fine pitch SMDs. Reflow soldering is ideal for the small pitches and high densities that come with increased miniaturization.

### 16.2 Wave and reflow soldering

Wave soldering is a joining technology in which the joints are made by solder coming from a standing wave of liquid solder. The wave soldering process is suitable for the following:

- Through-hole components
- Leaded or leadless SMDs, which are glued to the surface of the printed circuit board

Not all SMDs can be wave soldered. Packages with solder balls, and some leadless packages which have solder lands underneath the body, cannot be wave soldered. Also, leaded SMDs with leads having a pitch smaller than ~0.6 mm cannot be wave soldered, due to an increased probability of bridging.

The reflow soldering process involves applying solder paste to a board, followed by component placement and exposure to a temperature profile. Leaded packages, packages with solder balls, and leadless packages are all reflow solderable.

Key characteristics in both wave and reflow soldering are:

- Board specifications, including the board finish, solder masks and vias
- Package footprints, including solder thieves and orientation
- The moisture sensitivity level of the packages
- Package placement
- Inspection and repair
- Lead-free soldering versus SnPb soldering

### 16.3 Wave soldering

Key characteristics in wave soldering are:

- Process issues, such as application of adhesive and flux, clinching of leads, board transport, the solder wave parameters, and the time during which components are exposed to the wave
- Solder bath specifications, including temperature and impurities

**16.4 Reflow soldering**

Key characteristics in reflow soldering are:

- Lead-free versus SnPb soldering; note that a lead-free reflow process usually leads to higher minimum peak temperatures (see [Figure 12](#)) than a SnPb process, thus reducing the process window
- Solder paste printing issues including smearing, release, and adjusting the process window for a mix of large and small components on one board
- Reflow temperature profile; this profile includes preheat, reflow (in which the board is heated to the peak temperature) and cooling down. It is imperative that the peak temperature is high enough for the solder to make reliable solder joints (a solder paste characteristic). In addition, the peak temperature must be low enough that the packages and/or boards are not damaged. The peak temperature of the package depends on package thickness and volume and is classified in accordance with [Table 8](#) and [Table 9](#)

**Table 8. SnPb eutectic process (from J-STD-020D)**

Package thickness (mm)	Package reflow temperature (°C)	
	Volume (mm <sup>3</sup> )	
	< 350	≥ 350
< 2.5	235	220
≥ 2.5	220	220

**Table 9. Lead-free process (from J-STD-020D)**

Package thickness (mm)	Package reflow temperature (°C)		
	Volume (mm <sup>3</sup> )		
	< 350	350 to 2000	> 2000
< 1.6	260	260	260
1.6 to 2.5	260	250	245
> 2.5	250	245	245

Moisture sensitivity precautions, as indicated on the packing, must be respected at all times.

Studies have shown that small packages reach higher temperatures during reflow soldering, see [Figure 12](#).

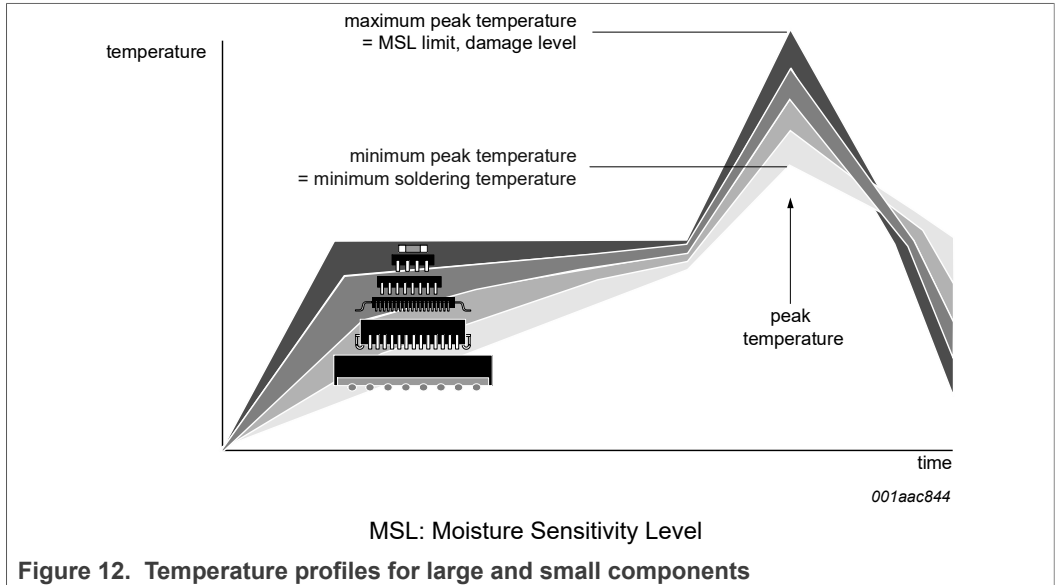

For further information on temperature profiles, refer to Application Note AN10365 “Surface mount reflow soldering description”.

## 17 Revision history

Table 10. Revision history

Document ID	Release date	Data sheet status	Change notice	Supersedes
TJA1028 v.5	20230130	Product data sheet		TJA1028 v.4
Modifications:	<ul style="list-style-type: none"> <li>• Added variants TJA1028AT(K), TJA1028BT(K), TJA1028CT(K) and TJA1028DT(K)</li> <li>• 'master/slave' replaced by 'commander/responder' throughout document</li> <li>• <a href="#">Section 2</a>: added ISO 17987-4:2016 (12 V) compliance</li> <li>• <a href="#">Section 3</a>: section added</li> <li>• Section 4 'Marking' removed</li> <li>• <a href="#">Table 3</a>: added pin type column</li> <li>• <a href="#">Figure 5</a>: amended text on RXD trace</li> <li>• <a href="#">Table 4</a>: format and footnotes revised; no specification changes</li> <li>• <a href="#">Table 5</a>: parameter definitions and specifications updated</li> <li>• <a href="#">Section 12</a>: section added</li> <li>• Section 13: test informatin section removed</li> <li>• <a href="#">Section 18</a>: legal information updated</li> </ul>			
TJA1028 v.4	20120725	Product data sheet	-	TJA1028 v.3
TJA1028 v.3	20110519	Product data sheet	-	TJA1028 v.2
TJA1028 v.2	20100225	Product data sheet	-	TJA1028 v.1
TJA1028 v.1	20100921	Product data sheet	-	-

## 18 Legal information

### 18.1 Data sheet status

Document status <sup>[1][2]</sup>	Product status <sup>[3]</sup>	Definition
Objective [short] data sheet	Development	This document contains data from the objective specification for product development.
Preliminary [short] data sheet	Qualification	This document contains data from the preliminary specification.
Product [short] data sheet	Production	This document contains the product specification.

[1] Please consult the most recently issued document before initiating or completing a design.

[2] The term 'short data sheet' is explained in section "Definitions".

[3] The product status of device(s) described in this document may have changed since this document was published and may differ in case of multiple devices. The latest product status information is available on the Internet at URL <http://www.nxp.com>.

### 18.2 Definitions

**Draft** — A draft status on a document indicates that the content is still under internal review and subject to formal approval, which may result in modifications or additions. NXP Semiconductors does not give any representations or warranties as to the accuracy or completeness of information included in a draft version of a document and shall have no liability for the consequences of use of such information.

**Short data sheet** — A short data sheet is an extract from a full data sheet with the same product type number(s) and title. A short data sheet is intended for quick reference only and should not be relied upon to contain detailed and full information. For detailed and full information see the relevant full data sheet, which is available on request via the local NXP Semiconductors sales office. In case of any inconsistency or conflict with the short data sheet, the full data sheet shall prevail.

**Product specification** — The information and data provided in a Product data sheet shall define the specification of the product as agreed between NXP Semiconductors and its customer, unless NXP Semiconductors and customer have explicitly agreed otherwise in writing. In no event however, shall an agreement be valid in which the NXP Semiconductors product is deemed to offer functions and qualities beyond those described in the Product data sheet.

### 18.3 Disclaimers

**Limited warranty and liability** — Information in this document is believed to be accurate and reliable. However, NXP Semiconductors does not give any representations or warranties, expressed or implied, as to the accuracy or completeness of such information and shall have no liability for the consequences of use of such information. NXP Semiconductors takes no responsibility for the content in this document if provided by an information source outside of NXP Semiconductors.

In no event shall NXP Semiconductors be liable for any indirect, incidental, punitive, special or consequential damages (including - without limitation - lost profits, lost savings, business interruption, costs related to the removal or replacement of any products or rework charges) whether or not such damages are based on tort (including negligence), warranty, breach of contract or any other legal theory.

Notwithstanding any damages that customer might incur for any reason whatsoever, NXP Semiconductors' aggregate and cumulative liability towards customer for the products described herein shall be limited in accordance with the Terms and conditions of commercial sale of NXP Semiconductors.

**Right to make changes** — NXP Semiconductors reserves the right to make changes to information published in this document, including without limitation specifications and product descriptions, at any time and without notice. This document supersedes and replaces all information supplied prior to the publication hereof.

**Applications** — Applications that are described herein for any of these products are for illustrative purposes only. NXP Semiconductors makes no representation or warranty that such applications will be suitable for the specified use without further testing or modification.

Customers are responsible for the design and operation of their applications and products using NXP Semiconductors products, and NXP Semiconductors accepts no liability for any assistance with applications or customer product design. It is customer's sole responsibility to determine whether the NXP Semiconductors product is suitable and fit for the customer's applications and products planned, as well as for the planned application and use of customer's third party customer(s). Customers should provide appropriate design and operating safeguards to minimize the risks associated with their applications and products.

NXP Semiconductors does not accept any liability related to any default, damage, costs or problem which is based on any weakness or default in the customer's applications or products, or the application or use by customer's third party customer(s). Customer is responsible for doing all necessary testing for the customer's applications and products using NXP Semiconductors products in order to avoid a default of the applications and the products or of the application or use by customer's third party customer(s). NXP does not accept any liability in this respect.

**Limiting values** — Stress above one or more limiting values (as defined in the Absolute Maximum Ratings System of IEC 60134) will cause permanent damage to the device. Limiting values are stress ratings only and (proper) operation of the device at these or any other conditions above those given in the Recommended operating conditions section (if present) or the Characteristics sections of this document is not warranted. Constant or repeated exposure to limiting values will permanently and irreversibly affect the quality and reliability of the device.

**Terms and conditions of commercial sale** — NXP Semiconductors products are sold subject to the general terms and conditions of commercial sale, as published at <http://www.nxp.com/profile/terms>, unless otherwise agreed in a valid written individual agreement. In case an individual agreement is concluded only the terms and conditions of the respective agreement shall apply. NXP Semiconductors hereby expressly objects to applying the customer's general terms and conditions with regard to the purchase of NXP Semiconductors products by customer.

**No offer to sell or license** — Nothing in this document may be interpreted or construed as an offer to sell products that is open for acceptance or the grant, conveyance or implication of any license under any copyrights, patents or other industrial or intellectual property rights.

**Suitability for use in automotive applications** — This NXP product has been qualified for use in automotive applications. If this product is used by customer in the development of, or for incorporation into, products or services (a) used in safety critical applications or (b) in which failure could lead to death, personal injury, or severe physical or environmental damage (such products and services hereinafter referred to as “Critical Applications”), then customer makes the ultimate design decisions regarding its products and is solely responsible for compliance with all legal, regulatory, safety, and security related requirements concerning its products, regardless of any information or support that may be provided by NXP. As such, customer assumes all risk related to use of any products in Critical Applications and NXP and its suppliers shall not be liable for any such use by customer. Accordingly, customer will indemnify and hold NXP harmless from any claims, liabilities, damages and associated costs and expenses (including attorneys’ fees) that NXP may incur related to customer’s incorporation of any product in a Critical Application.

**Quick reference data** — The Quick reference data is an extract of the product data given in the Limiting values and Characteristics sections of this document, and as such is not complete, exhaustive or legally binding.

**Export control** — This document as well as the item(s) described herein may be subject to export control regulations. Export might require a prior authorization from competent authorities.

**Translations** — A non-English (translated) version of a document, including the legal information in that document, is for reference only. The English version shall prevail in case of any discrepancy between the translated and English versions.

**Security** — Customer understands that all NXP products may be subject to unidentified vulnerabilities or may support established security standards or specifications with known limitations. Customer is responsible for the design and operation of its applications and products throughout their lifecycles to reduce the effect of these vulnerabilities on customer’s applications and products. Customer’s responsibility also extends to other open and/or proprietary technologies supported by NXP products for use in customer’s applications. NXP accepts no liability for any vulnerability. Customer should regularly check security updates from NXP and follow up appropriately. Customer shall select products with security features that best meet rules, regulations, and standards of the intended application and make the ultimate design decisions regarding its products and is solely responsible for compliance with all legal, regulatory, and security related requirements concerning its products, regardless of any information or support that may be provided by NXP.

NXP has a Product Security Incident Response Team (PSIRT) (reachable at [PSIRT@nxp.com](mailto:PSIRT@nxp.com)) that manages the investigation, reporting, and solution release to security vulnerabilities of NXP products.

## 18.4 Trademarks

Notice: All referenced brands, product names, service names, and trademarks are the property of their respective owners.

**NXP** — wordmark and logo are trademarks of NXP B.V.