

Low noise JFET dual operational amplifiers

Datasheet - production data

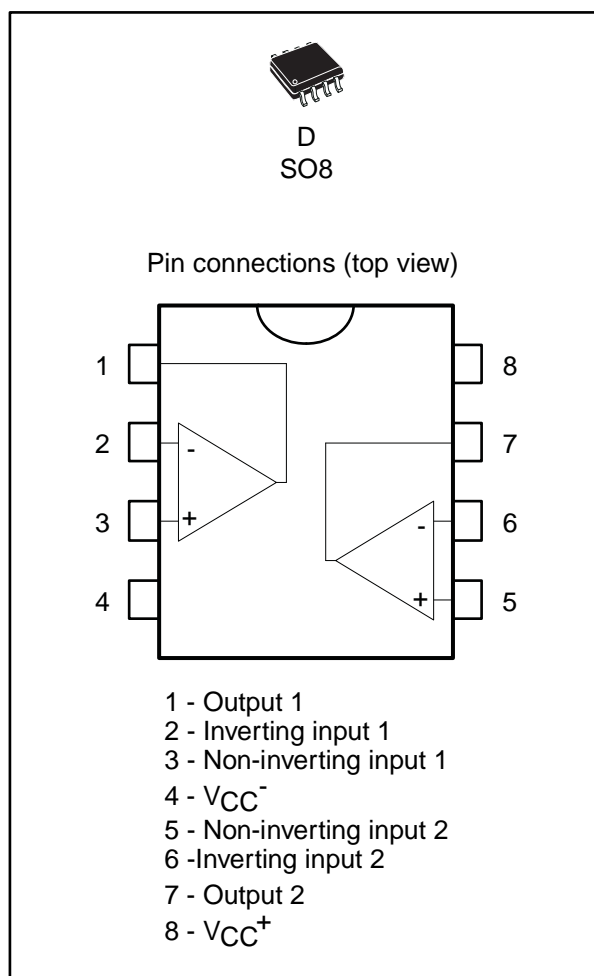

Features

- Wide common-mode (up to V_{CC}^+) and differential voltage range
- Low input bias and offset current
- Low noise $e_n = 15 \text{ nV}/\sqrt{\text{Hz}}$ (typ)
- Output short-circuit protection
- High input impedance JFET input stage
- Low harmonic distortion: 0.01 % (typical)
- Internal frequency compensation
- Latch-up free operation
- High slew rate: $16 \text{ V}/\mu\text{s}$ (typ)

Related products

- See TL071 for single op amp version
- See TL074 for quad op amp version

Description

The TL072, TL072A, and TL072B are high speed JFET input dual operational amplifiers incorporating well-matched, high-voltage JFET and bipolar transistors in a monolithic integrated circuit.

The devices feature high slew rates, low input bias and offset current, and low offset voltage temperature coefficients.

Contents

1	Schematic diagram.....	3
2	Absolute maximum ratings and operating conditions	4
3	Electrical characteristics	5
4	Parameter measurement information	10
5	Typical application	11
6	Package information	12
	6.1 SO8 package information.....	12
7	Ordering information.....	14
8	Revision history	15

1 Schematic diagram

Figure 1: Schematic diagram

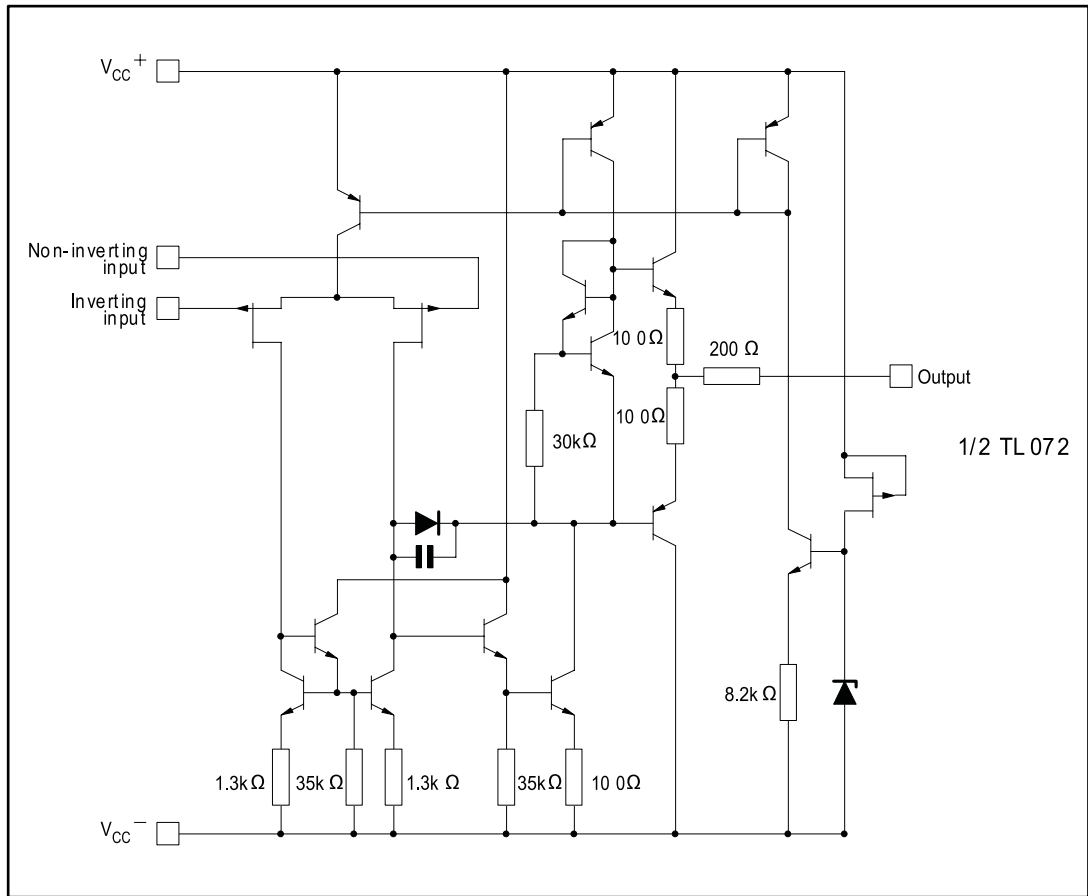

2 Absolute maximum ratings and operating conditions

Table 1: Absolute maximum ratings

Symbol	Parameter	TL072I, AI, BI	TL072C, AC, BC	Unit
V_{CC}	Supply voltage ⁽¹⁾	±18		V
V_{in}	Input voltage ⁽²⁾	±15		
V_{id}	Differential input voltage ⁽³⁾	±30		
R_{thja}	Thermal resistance junction to ambient, SO8 ⁽⁴⁾	125		°C/W
R_{thjc}	Thermal resistance junction to case, SO8 ⁽⁴⁾	40		
	Output short-circuit duration ⁽⁵⁾	Infinite		
T_{stg}	Storage temperature range	-65 to +150		°C
ESD	HBM: human body model ⁽⁶⁾	1		kV
	MM: machine model ⁽⁷⁾	200		V
	CDM: charged device model ⁽⁸⁾	1.5		kV

Notes:

⁽¹⁾All voltage values, except the differential voltage, are with respect to the zero reference level (ground) of the supply voltages where the zero reference level is the midpoint between V_{CC}^+ and V_{CC}^- .

⁽²⁾The magnitude of the input voltage must never exceed the magnitude of the supply voltage or 15 volts, whichever is less.

⁽³⁾Differential voltages are the non-inverting input terminal voltages with respect to the inverting input terminal.

⁽⁴⁾Short-circuits can cause excessive heating. Destructive dissipation can result from simultaneous short-circuits on all amplifiers.

⁽⁵⁾The output may be shorted to ground or to either supply. Temperature and/or supply voltages must be limited to ensure that the dissipation rating is not exceeded.

⁽⁶⁾Human body model: 100 pF discharged through a 1.5 kΩ resistor between two pins of the device. This is done for all couples of pin combinations with other pins floating.

⁽⁷⁾Machine model: a 200 pF cap is charged to the specified voltage, then discharged directly between two pins of the device with no external series resistor (internal resistor < 5 W). This is done for all couples of pin combinations with other pins floating.

⁽⁸⁾Charged device model: all pins plus package are charged together to the specified voltage and then discharged directly to the ground.

Table 2: Operating conditions

Symbol	Parameter	TL072I, AI, BI	TL072C, AC, BC	Unit
V_{CC}	Supply voltage	6 to 36		V
T_{oper}	Operating free-air temperature range	-40 to +125	0 to +70	°C

3 Electrical characteristics

Table 3: Electrical characteristics at VCC = ±15 V, Tamb = +25 °C (unless otherwise specified).

Symbol	Parameter	TL072I, AC, AI, BC, BI			TL072C			Unit	
		Min.	Typ.	Max.	Min.	Typ.	Max.		
V _{io}	Input offset voltage (R _s = 50 Ω) T _{amb} = +25 °C	TL072		3	10		3	10	mV
		TL072A		3	6				
		TL072B		1	3				
	Input offset voltage (R _s = 50 Ω) T _{min} ≤ T _{amb} ≤ T _{max}	TL072			13			13	
		TL072A			7				
		TL072B			5				
ΔV _{io} /ΔT	Input offset voltage drift		10			10		μV/°C	
I _{io}	Input offset current, T _{amb} = +25 °C ⁽¹⁾		5	100		5	100	pA	
	Input offset current, T _{min} ≤ T _{amb} ≤ T _{max}			4			10	nA	
I _{ib}	Input bias current, T _{amb} = +25 °C ⁽¹⁾		20	200		20	200	pA	
	Input bias current, T _{min} ≤ T _{amb} ≤ T _{max} ⁽¹⁾			20			20	nA	
A _{vd}	Large signal voltage gain (R _L = 2 kΩ, V _o = ±10 V), T _{amb} = +25 °C	50	200		25	200		V/mV	
	Large signal voltage gain (R _L = 2 kΩ, V _o = ±10 V), T _{min} ≤ T _{amb} ≤ T _{max}	25			15				
SVR	Supply voltage rejection ratio (R _S = 50 Ω), T _{amb} = +25 °C	80	86		70	86		dB	
	Supply voltage rejection ratio (R _S = 50 Ω), T _{min} ≤ T _{amb} ≤ T _{max}	80			70				
I _{CC}	Supply current, no load, T _{amb} = +25 °C		1.4	2.5		1.4	2.5	mA	
	Supply current, no load, T _{min} ≤ T _{amb} ≤ T _{max}			2.5			2.5		
V _{icm}	Input common mode voltage range	±11	-12 to +15		±11	-12 to +15		V	
CMR	Common mode rejection ratio (R _S = 50 Ω), T _{amb} = +25 °C	80	86		70	86		dB	
	Common mode rejection ratio (R _S = 50 Ω), T _{min} ≤ T _{amb} ≤ T _{max}	80			70				
I _{os}	Output short-circuit current, T _{amb} = +25 °C	10	40	60	10	40	60	mA	
	Output short-circuit current, T _{min} ≤ T _{amb} ≤ T _{max}	10		60	10		60		
±V _{opp}	Output voltage swing, T _{amb} = +25 °C	R _L = 2 kΩ	10	12		10	12	V	
		R _L = 10 kΩ	12	13.5		12	13.5		
	Output voltage swing, T _{min} ≤ T _{amb} ≤ T _{max}	R _L = 2 kΩ	10			10			
		R _L = 10 kΩ	12			12			

Electrical characteristics

TL072, TL072A, TL072B

Symbol	Parameter	TL072I, AC, AI, BC, BI			TL072C			Unit
		Min.	Typ.	Max.	Min.	Typ.	Max.	
SR	Slew rate, $V_{in} = 10\text{ V}$, $R_L = 2\text{ k}\Omega$, $C_L = 100\text{ pF}$, unity gain	8	16		8	16		V/ μs
t_r	Rise time, $V_{in} = 20\text{ mV}$, $R_L = 2\text{ k}\Omega$, $C_L = 100\text{ pF}$, unity gain		0.1			0.1		μs
K_{ov}	Overshoot, $V_{in} = 20\text{ mV}$, $R_L = 2\text{ k}\Omega$, $C_L = 100\text{ pF}$, unity gain		10			10		%
GBP	Gain bandwidth product, $V_{in} = 10\text{ mV}$, $R_L = 2\text{ k}\Omega$, $C_L = 100\text{ pF}$, $F = 100\text{ kHz}$	2.5	4		2.5	4		MHz
R_i	Input resistance		10^{12}			10^{12}		Ω
THD	Total harmonic distortion, $F = 1\text{ kHz}$, $R_L = 2\text{ k}\Omega$, $C_L = 100\text{ pF}$, $A_v = 20\text{ dB}$, $V_o = 2\text{ V}_{pp}$		0.01			0.01		%
e_n	Equivalent input noise voltage, $R_S = 100\ \Omega$, $F = 1\text{ kHz}$		15			15		$\frac{\text{nV}}{\sqrt{\text{Hz}}}$
ϕ_m	Phase margin		45			45		degrees
V_{o1}/V_{o2}	Channel separation, $A_v = 100$		120			120		dB

Notes:

(1) The input bias currents are junction leakage currents which approximately double for every 10 °C increase in the junction temperature.

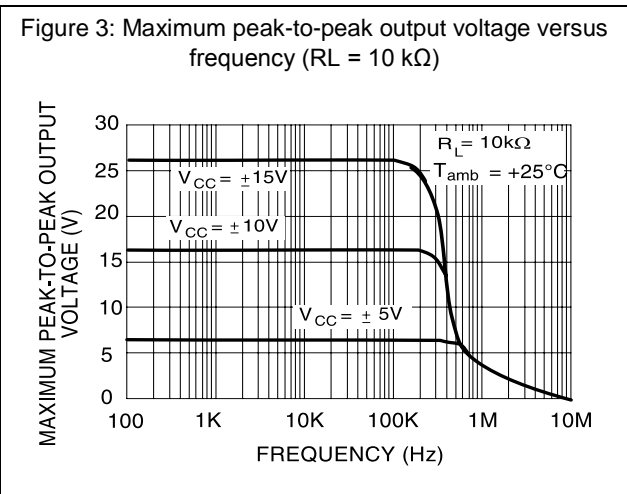
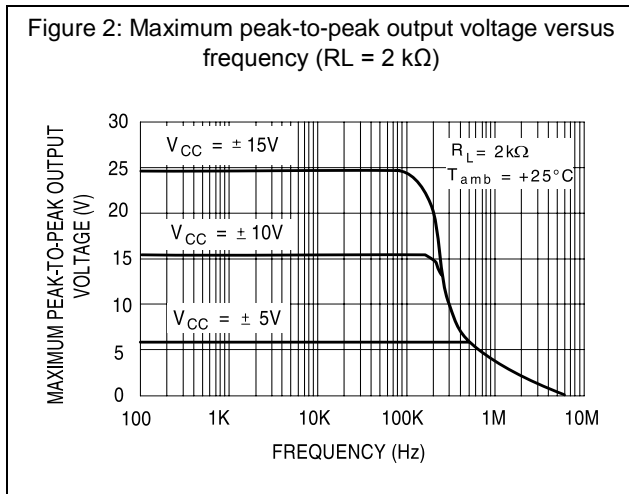

Figure 4: Maximum peak-to-peak output voltage versus frequency

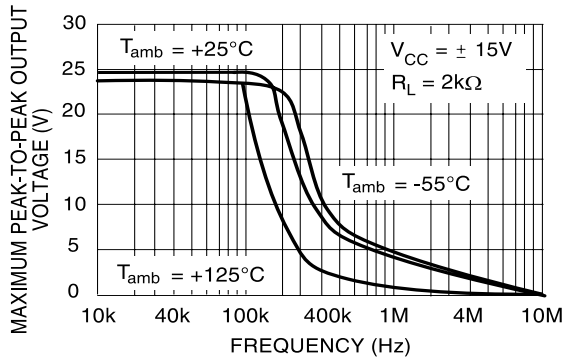

Figure 5: Maximum peak-to-peak output voltage versus free air temperature

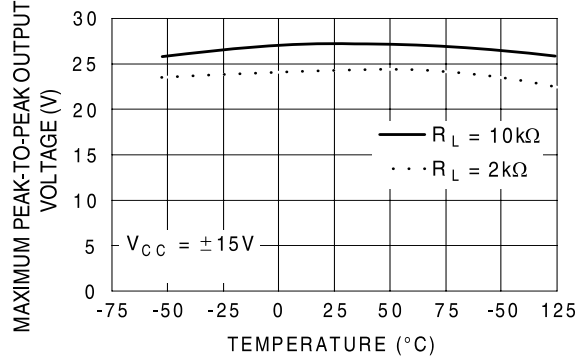

Figure 6: Maximum peak-to-peak output voltage versus load resistance

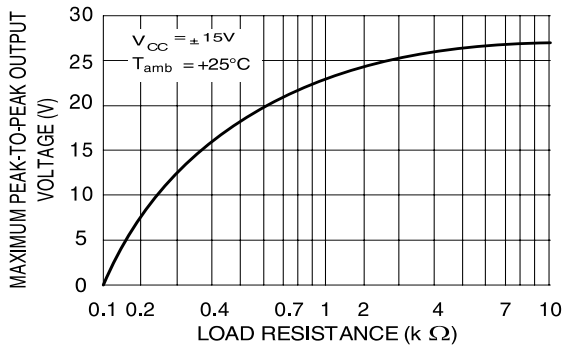

Figure 7: Maximum peak-to-peak output voltage versus supply voltage

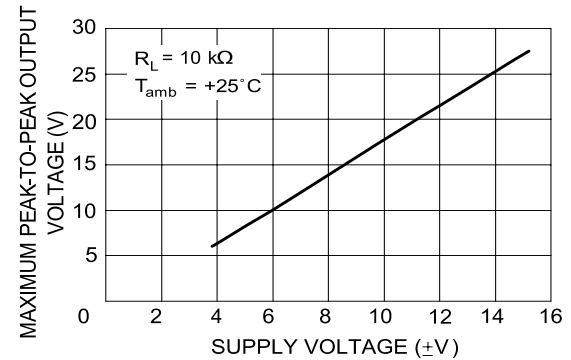

Figure 8: Input bias current versus free air temperature

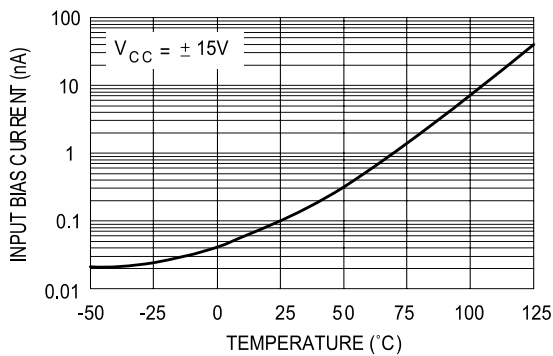

Figure 9: Large signal differential voltage amplification versus free air temperature

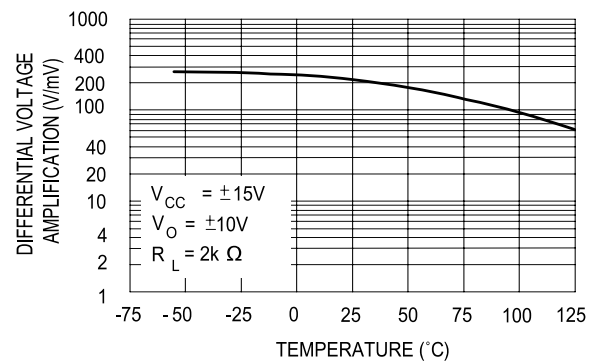

Figure 10: Large signal differential voltage amplification and phase shift versus frequency

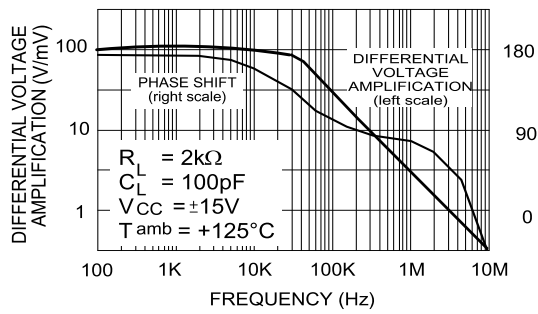

Figure 11: Total power dissipation versus free air temperature

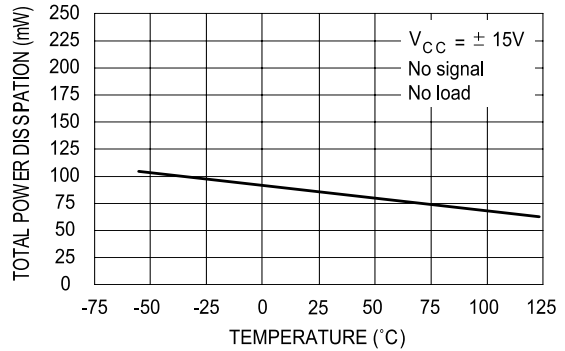

Figure 12: Supply current per amplifier versus free air temperature

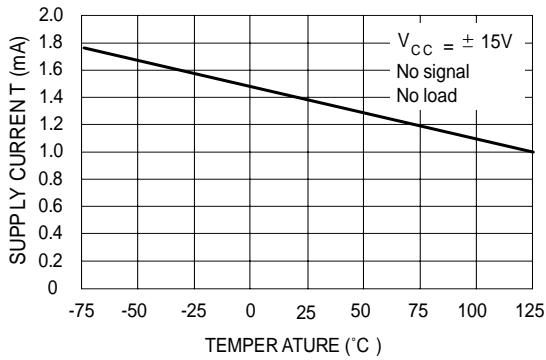

Figure 13: Common mode rejection ratio versus free air temperature

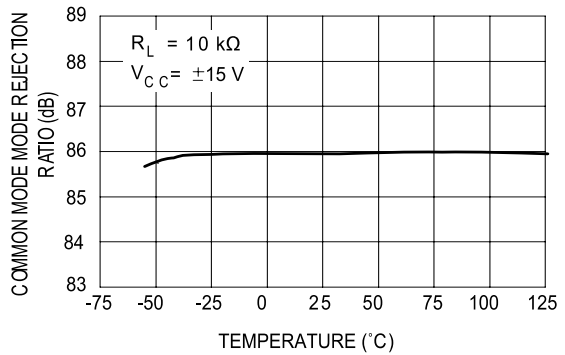

Figure 14: Voltage follower large signal pulse response

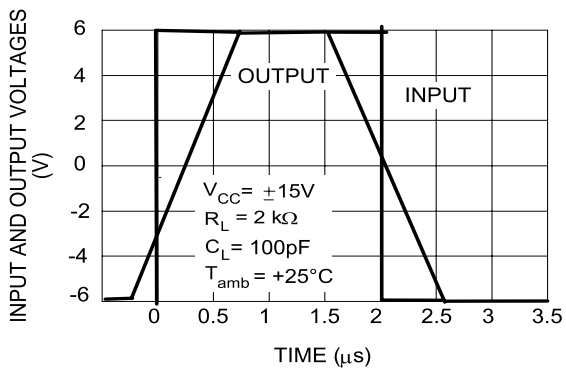

Figure 15: Output voltage versus elapsed time

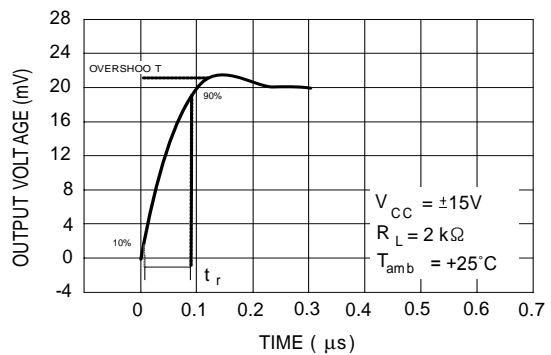

Figure 16: Equivalent input noise voltage versus frequency

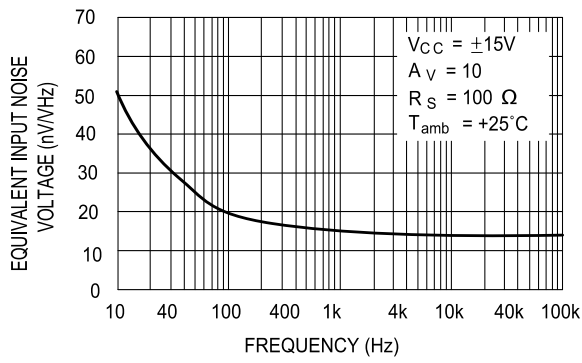
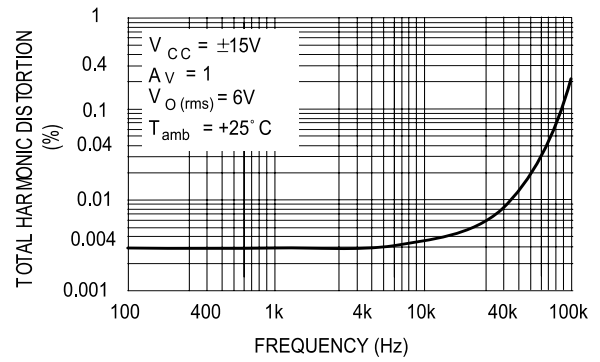

Figure 17: Total harmonic distortion versus frequency



4 Parameter measurement information

Figure 18: Voltage follower

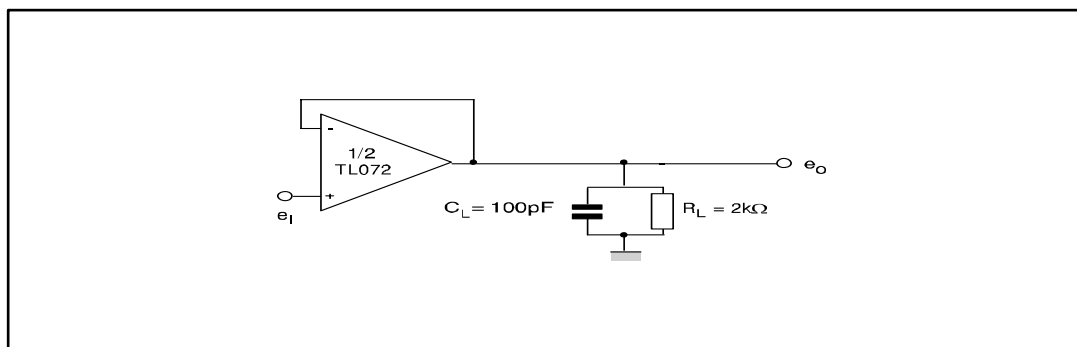
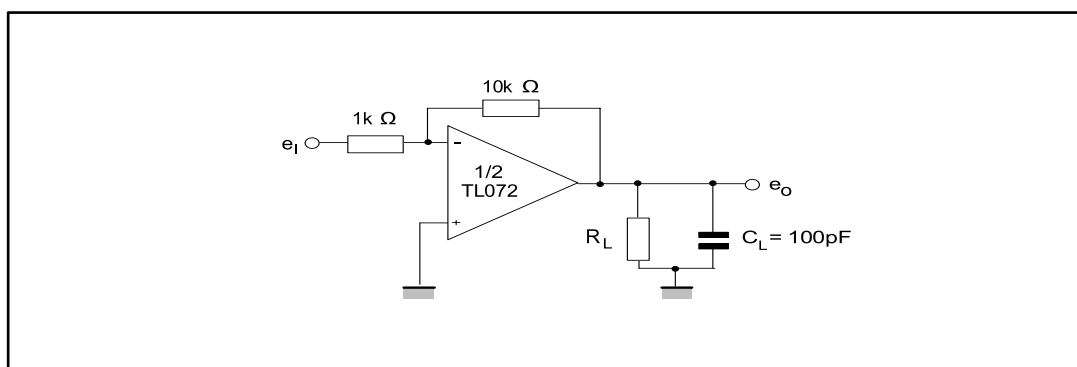
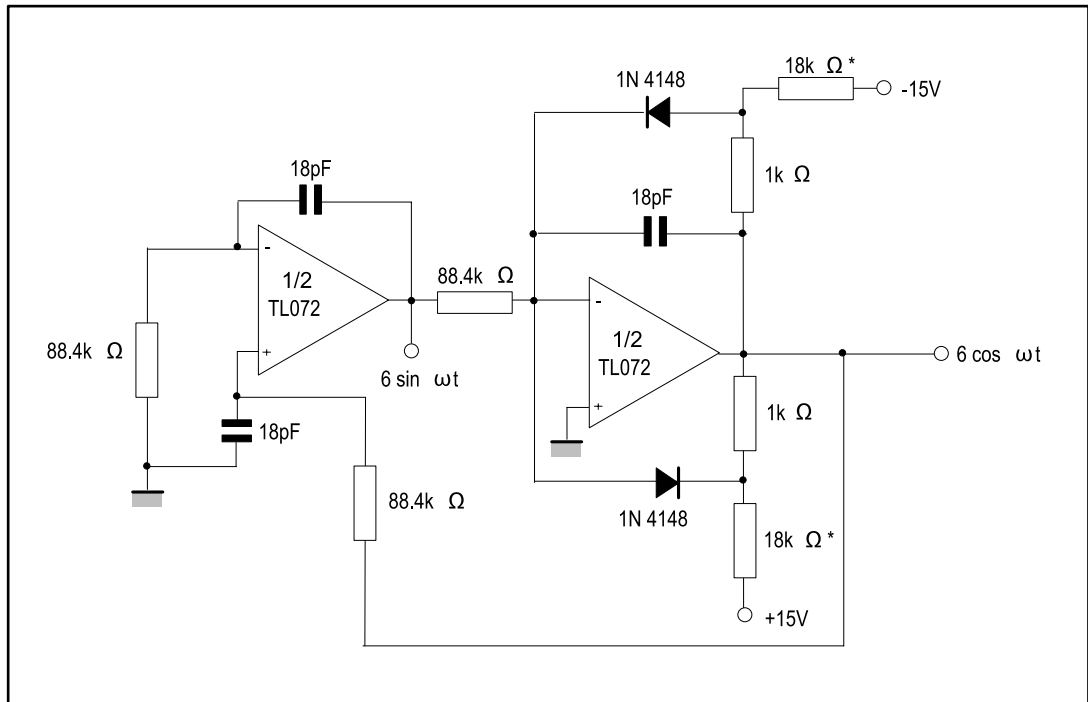

Figure 19: Gain-of-10 inverting amplifier



5 Typical application

Figure 20: 100 kHz quadruple oscillator



1. The resistor values of [Figure 20](#) may be adjusted for a symmetrical output

6 Package information

In order to meet environmental requirements, ST offers these devices in different grades of ECOPACK® packages, depending on their level of environmental compliance. ECOPACK® specifications, grade definitions and product status are available at: www.st.com. ECOPACK is an ST trademark.

6.1 SO8 package information

Figure 21: SO8 package mechanical drawing

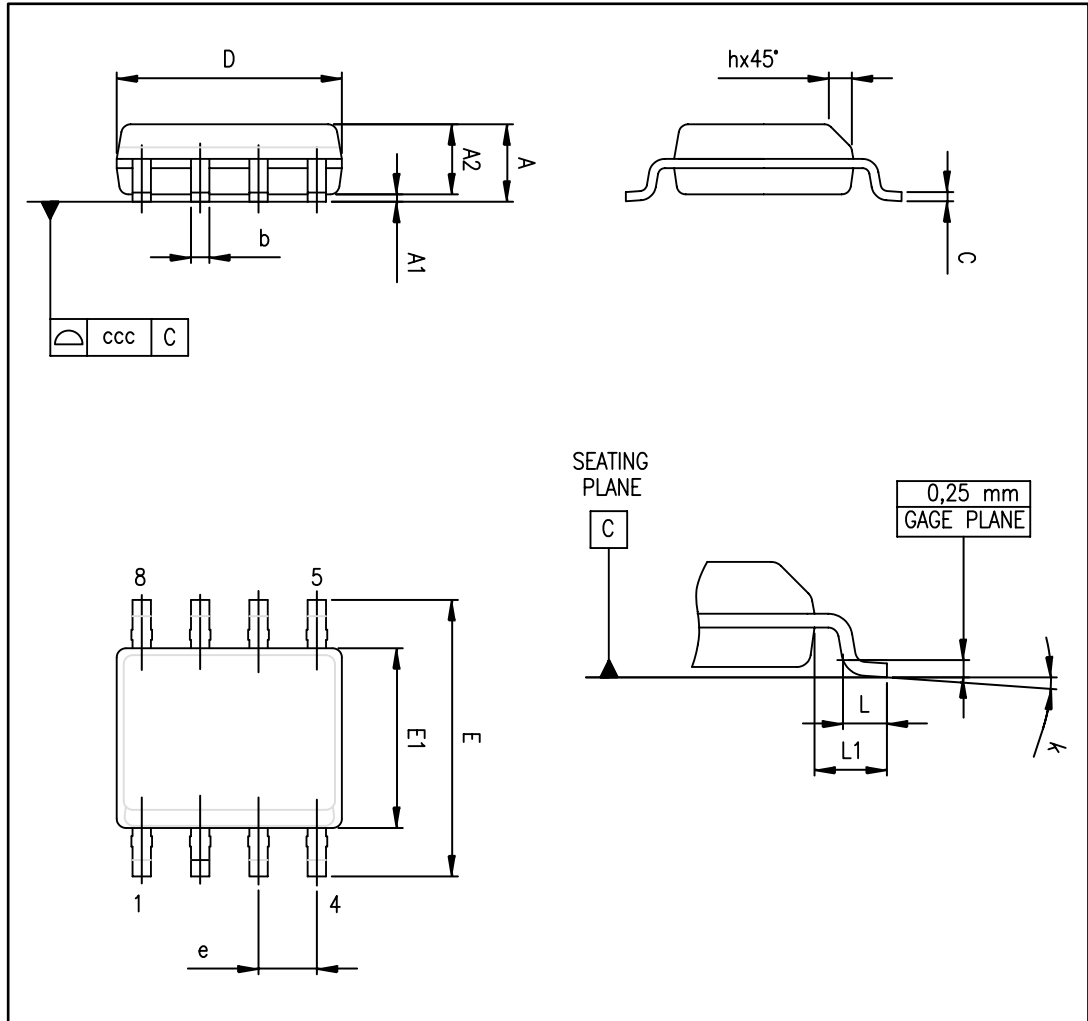

Table 4: SO8 package mechanical data

Ref.	Dimensions					
	Millimeters			Inches		
	Min.	Typ.	Max.	Min.	Typ.	Max.
A			1.75			0.069
A1	0.10		0.25	0.004		0.010
A2	1.25			0.049		
b	0.28		0.48	0.011		0.019
c	0.17		0.23	0.007		0.010
D	4.80	4.90	5.00	0.189	0.193	0.197
E	5.80	6.00	6.20	0.228	0.236	0.244
E1	3.80	3.90	4.00	0.150	0.154	0.157
e		1.27			0.050	
h	0.25		0.50	0.010		0.020
L	0.40		1.27	0.016		0.050
k	1°		8°	1°		8°
ccc			0.10			0.004

7 Ordering information

Table 5: Order codes

Order code	Temperature range	Package	Packing	Marking
TL072IDT	-40 °C, +125 °C	SO8	Tape and reel	072I
TL072AIDT				072AI
TL072BIDT				072BI
TL072CDT	0 °C, +70 °C			072C
TL072ACDT				072AC
TL072BCDT				072BC
TL072IYDT ⁽¹⁾	-40 °C, +125 °C	SO8 (automotive grade)		072IY
TL072AIYDT ⁽¹⁾				072AIY
TL072BIYDT ⁽¹⁾				072BIY

Notes:

⁽¹⁾ Qualified and characterized according to AEC Q100 and Q003 or equivalent, advanced screening according to AEC Q001 & Q002 or equivalent.

8 Revision history

Table 6: Document revision history

Date	Revision	Changes
28-Mar-2001	1	Initial release.
02-Apr-2004	2	Correction to pin connection diagram on cover page. Unpublished.
04-Dec-2006	3	Modified graphics in package mechanical data.
06-Mar-2007	4	Expanded order codes table and added automotive grade order codes. See Table 5: "Order codes" . Added thermal resistance and ESD tolerance in Table 1: "Absolute maximum ratings" . Added Table 2: "Operating conditions" . Updated package mechanical data to make it compliant with the latest JEDEC standards.
13-Mar-2008	5	ESD HBM value modified in AMR table. Re-ordered order codes table. Removed TL072BIY and TL072AIY order codes from order code table. Corrected footnote for automotive grade order codes in order codes table.
15-Jul-2008	6	Removed information concerning military temperature range (TL072Mx, TL072AMx, TL072BMx). Added order codes for automotive grade products in Table 5: "Order codes" .
04-Jul-2012	7	Removed part numbers TL072IYD, TL072AIYD, TL072BIYD. Updated Table 5: "Order codes" .
19-Jun-2014	8	Removed DIP8 package Added Related products Table 2: "Operating conditions" : temperature range for "I" versions changed from "-40 °C, +105 °C" to "-40 °C, +125 °C". Table 3: Electrical characteristics at VCC = ±15 V, Tamb = +25 °C (unless otherwise specified) : replaced DV _{io} with ΔV _{io} /ΔT. Table 5: "Order codes" : temperature range for "I" version order codes changed from "-40 °C, +105 °C" to "-40 °C, +125 °C"; removed tube packing and related order codes. Updated disclaimer