

Low-noise JFET quad operational amplifier

Datasheet - production data

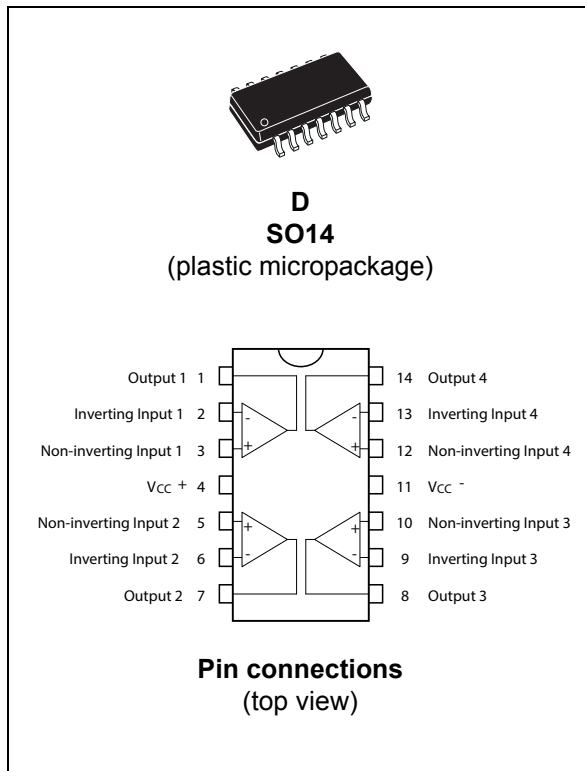

Related products

- See TL071 for single version
- See TL072 for dual version

Description

The TL074, TL074A, and TL074B are high-speed JFET input single operational amplifiers. Each of these JFET input operational amplifiers incorporates well matched, high-voltage JFET and bipolar transistors in a monolithic integrated circuit.

The devices feature high slew rates, low input bias and offset currents, and low offset voltage temperature coefficient.

Features

- Wide common-mode (up to V_{CC}^+) and differential voltage range
- Low input bias and offset current
- Low noise $e_n = 15 \text{ nV}/\sqrt{\text{Hz}}$ (typ)
- Output short-circuit protection
- High input impedance JFET input stage
- Low harmonic distortion: 0.01% (typical)
- Internal frequency compensation
- Latch up free operation
- High slew rate: $16 \text{ V}/\mu\text{s}$ (typical)

Contents

1	Schematic diagram	3
2	Absolute maximum ratings and operating conditions	4
3	Electrical characteristics	5
4	Parameter measurement information	10
5	Typical applications	11
6	Package information	13
6.1	SO14 package information	14
7	Ordering information	16
8	Revision history	17

1 Schematic diagram

Figure 1. Circuit schematic

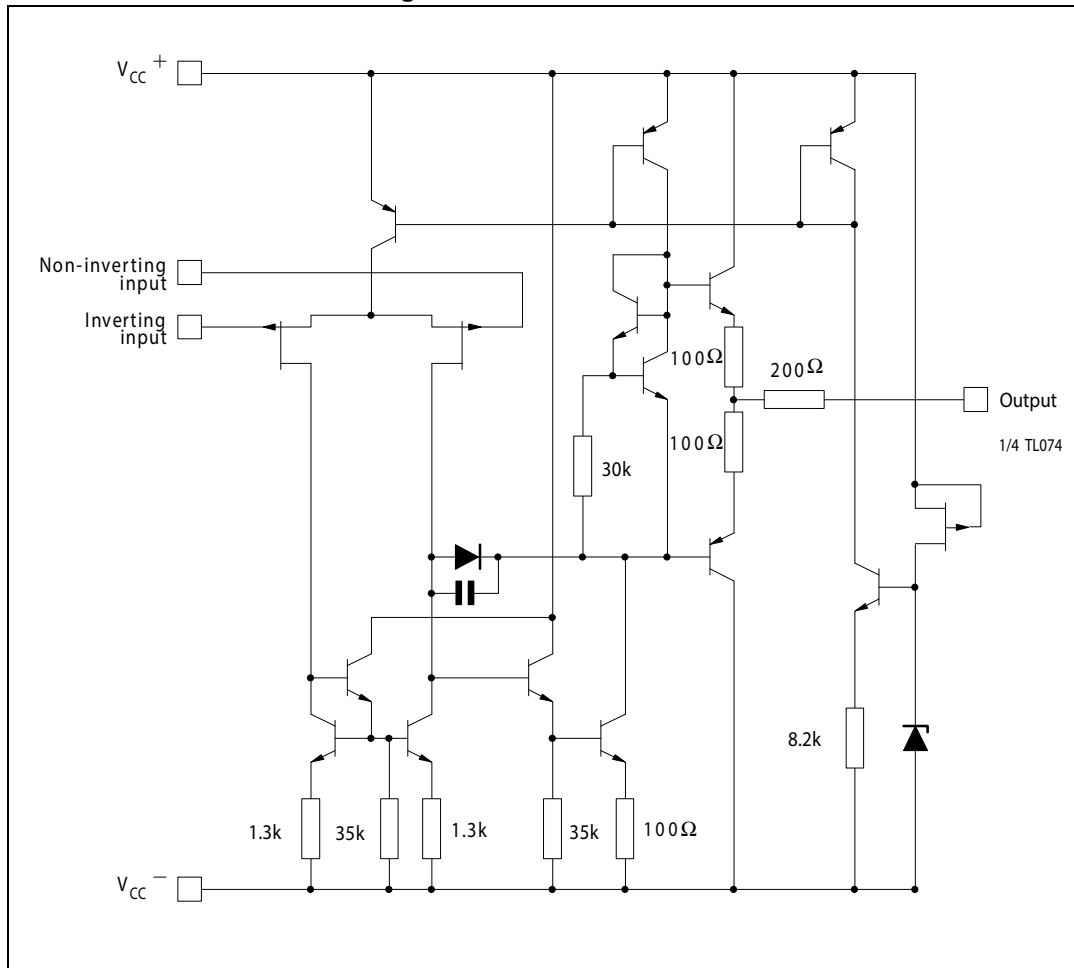

2 Absolute maximum ratings and operating conditions

Table 1. Absolute maximum ratings

Symbol	Parameter	Value		Unit
		TL074I, AI, BI	TL074C, AC, BC	
V _{CC}	Supply voltage ⁽¹⁾	±18		V
V _i	Input voltage ⁽²⁾	±15		
V _{id}	Differential input voltage ⁽³⁾	±30		
P _{tot}	Power dissipation	680		mW
R _{thja}	Thermal resistance junction to ambient ⁽⁴⁾⁽⁵⁾ SO14	105		°C/W
R _{thjc}	Thermal resistance junction to case ⁽⁴⁾⁽⁵⁾ SO14	31		
	Output short-circuit duration ⁽⁶⁾	Infinite		
T _{oper}	Operating free-air temperature range	-40 to +125	0 to +70	°C
T _{stg}	Storage temperature range	-65 to +150		
ESD	HBM: human body model ⁽⁷⁾	1		kV
	MM: machine model ⁽⁸⁾	200		V
	CDM: charged device model ⁽⁹⁾	1.5		kV

1. All voltage values, except differential voltage, are with respect to the zero reference level (ground) of the supply voltages where the zero reference level is the midpoint between V_{CC}⁺ and V_{CC}⁻.
2. The magnitude of the input voltage must never exceed the magnitude of the supply voltage or 15 volts, whichever is less.
3. Differential voltages are the non-inverting input terminal with respect to the inverting input terminal.
4. Short-circuits can cause excessive heating. Destructive dissipation can result from simultaneous short-circuits on all amplifiers.
5. R_{th} are typical values.
6. The output may be shorted to ground or to either supply. Temperature and/or supply voltages must be limited to ensure that the dissipation rating is not exceeded.
7. Human body model: 100pF discharged through a 1.5kΩ resistor between two pins of the device, done for all couples of pin combinations with other pins floating.
8. Machine model: a 200pF cap is charged to the specified voltage, then discharged directly between two pins of the device with no external series resistor (internal resistor < 5Ω), done for all couples of pin combinations with other pins floating.
9. Charged device model: all pins plus package are charged together to the specified voltage and then discharged directly to the ground.

Table 2. Operating conditions

Symbol	Parameter	TL074I, AI, BI	TL074C, AC, BC	Unit
V _{CC}	Supply voltage	6 to 36		V
T _{oper}	Operating free-air temperature range	-40 to +125	0 to +70	°C

3 Electrical characteristics

Table 3. $V_{CC} = \pm 15\text{ V}$, $T_{amb} = +25\text{ }^\circ\text{C}$ (unless otherwise specified)

Symbol	Parameter	TL074I,AC,AI, BC,BI			TL074C			Unit
		Min.	Typ.	Max.	Min.	Typ.	Max.	
V_{io}	Input offset voltage ($R_S = 50\Omega$)							mV
	$T_{amb} = +25\text{ }^\circ\text{C}$ TL074		3	10		3	10	
	TL074A		3	6				
	TL074B		1	3				
	$T_{min} \leq T_{amb} \leq T_{max}$ TL074			13			13	
	TL074A			7				
	TL074B			5				
DV_{io}	Input offset voltage drift		10			10		$\mu\text{V}/^\circ\text{C}$
I_{io}	Input offset current							pA nA
	$T_{amb} = +25\text{ }^\circ\text{C}$ $T_{min} \leq T_{amb} \leq T_{max}$		5	100 4		5	100 10	
I_{ib}	Input bias current -note ⁽¹⁾							pA nA
	$T_{amb} = +25\text{ }^\circ\text{C}$ $T_{min} \leq T_{amb} \leq T_{max}$		20	200 20		30	200 20	
A_{vd}	Large signal voltage gain $R_L = 2\text{ k}\Omega$, $V_o = \pm 10\text{ V}$							V/mV
	$T_{amb} = +25\text{ }^\circ\text{C}$ $T_{min} \leq T_{amb} \leq T_{max}$	50 25	200		25 15	200		
SVR	Supply voltage rejection ratio ($R_S = 50\Omega$)							dB
	$T_{amb} = +25\text{ }^\circ\text{C}$ $T_{min} \leq T_{amb} \leq T_{max}$	80 80	86		70 70	86		
I_{CC}	Supply current, no load							mA
	$T_{amb} = +25\text{ }^\circ\text{C}$ $T_{min} \leq T_{amb} \leq T_{max}$		1.4	2.5 2.5		1.4	2.5 2.5	
V_{icm}	Input common mode voltage range	± 11	+15 -12		± 11	+15 -12		V
CMR	Common mode rejection ratio ($R_S = 50\Omega$)							dB
	$T_{amb} = +25\text{ }^\circ\text{C}$ $T_{min} \leq T_{amb} \leq T_{max}$	80 80	86		70 70	86		
I_{os}	Output short-circuit current							mA
	$T_{amb} = +25\text{ }^\circ\text{C}$ $T_{min} \leq T_{amb} \leq T_{max}$	10 10	40	60 60	10 10	40	60 60	
$\pm V_{opp}$	Output voltage swing							V
	$T_{amb} = +25\text{ }^\circ\text{C}$ $R_L = 2\text{ k}\Omega$	10	12		10	12		
	$R_L = 10\text{ k}\Omega$	12	13.5		12	13.5		
	$T_{min} \leq T_{amb} \leq T_{max}$ $R_L = 2\text{ k}\Omega$	10			10			
	$R_L = 10\text{ k}\Omega$	12			12			
SR	Slew rate $V_{in} = 10\text{ V}$, $R_L = 2\text{ k}\Omega$, $C_L = 100\text{ pF}$, unity gain	8	13		8	13		V/ μs

Table 3. $V_{CC} = \pm 15\text{ V}$, $T_{amb} = +25\text{ }^\circ\text{C}$ (unless otherwise specified) (continued)

Symbol	Parameter	TL074I,AC,AI, BC,BI			TL074C			Unit
		Min.	Typ.	Max.	Min.	Typ.	Max.	
t_r	Rise time $V_{in} = 20\text{mV}$, $R_L = 2\text{k}\Omega$, $C_L = 100\text{pF}$, unity gain		0.1			0.1		μs
K_{ov}	Overshoot $V_{in} = 20\text{mV}$, $R_L = 2\text{k}\Omega$, $C_L = 100\text{pF}$, unity gain		10			10		%
GBP	Gain bandwidth product $V_{in} = 10\text{mV}$, $R_L = 2\text{k}\Omega$, $C_L = 100\text{pF}$, = 100kHz	2	3		2	3		MHz
R_i	Input resistance		10^{12}			10^{12}		Ω
THD	Total harmonic distortion $f = 1\text{kHz}$, $R_L = 2\text{k}\Omega$, $C_L = 100\text{pF}$, $A_v = 20\text{dB}$, $V_o = 2V_{pp}$		0.01			0.01		%
e_n	Equivalent input noise voltage $R_S = 100\Omega$, $f = 1\text{kHz}$		15			15		$\frac{\text{nV}}{\sqrt{\text{Hz}}}$
ϕ_m	Phase margin		45			45		degrees
V_{o1}/V_{o2}	Channel separation $A_v = 100$		120			120		dB

- The input bias currents are junction leakage currents which approximately double for every 10°C increase in the junction temperature.

Figure 2. Maximum peak-to-peak output voltage versus frequency

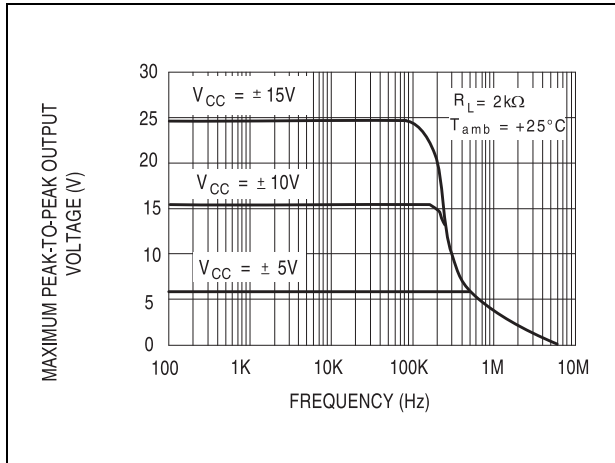

Figure 3. Maximum peak-to-peak output voltage versus frequency

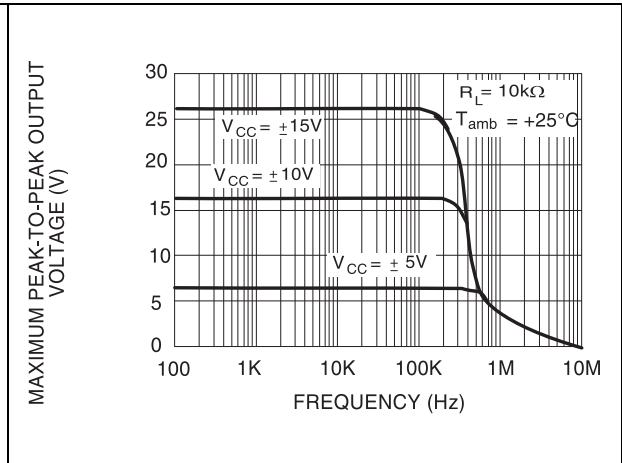

Figure 4. Maximum peak-to-peak output voltage versus frequency

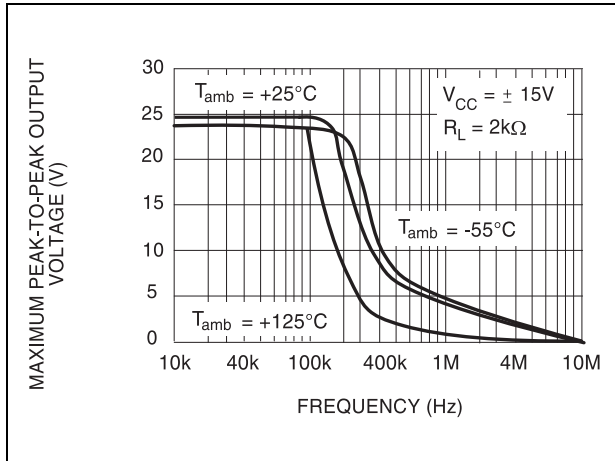

Figure 5. Maximum peak-to-peak output voltage versus free air temperature

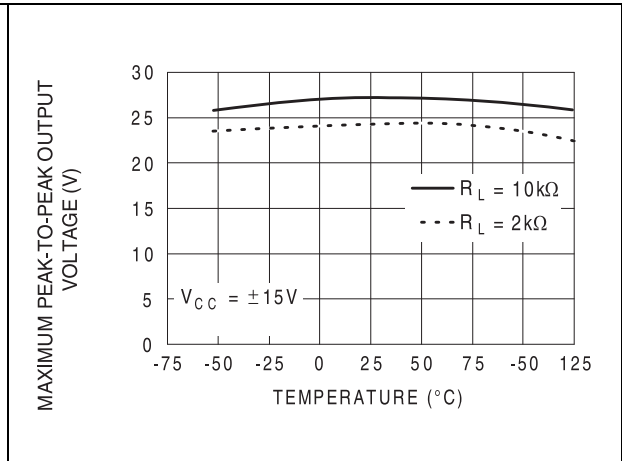

Figure 6. Maximum peak-to-peak output voltage versus load resistance

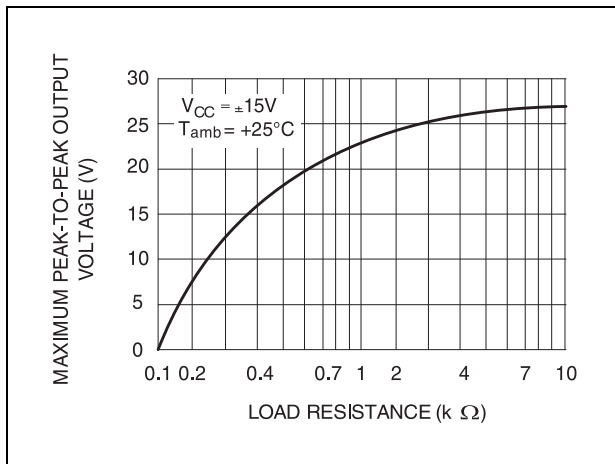

Figure 7. Maximum peak-to-peak output voltage versus supply voltage

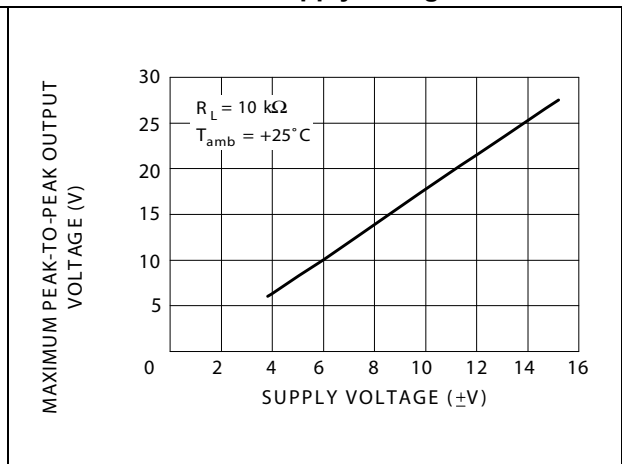

Figure 8. Input bias current versus free air temperature

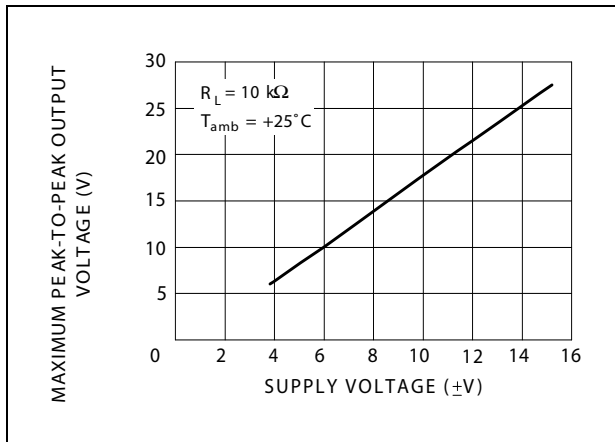

Figure 9. Large signal differential voltage amplification versus free air temperature

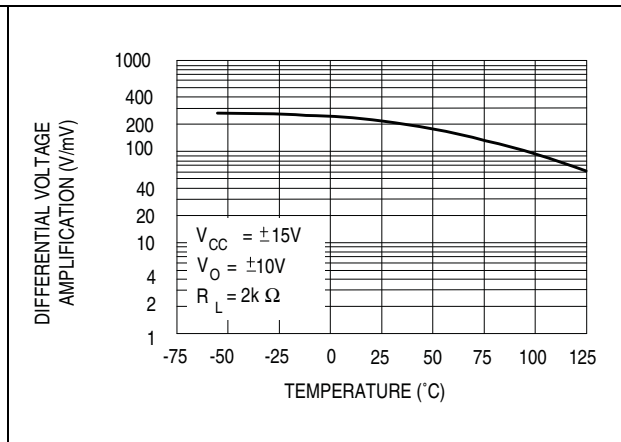

Figure 10. Large signal differential voltage amplification and phase shift versus frequency

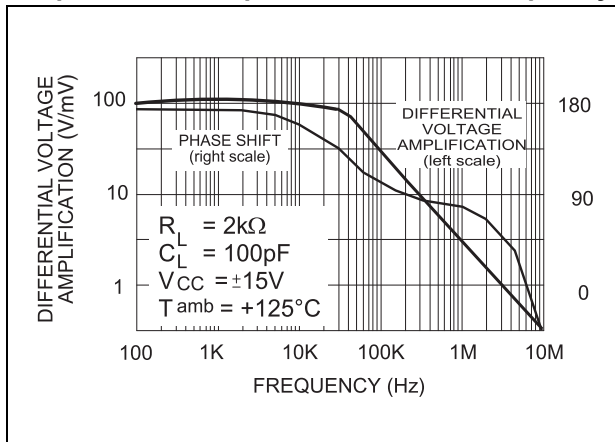

Figure 11. Total power dissipation versus free air temperature

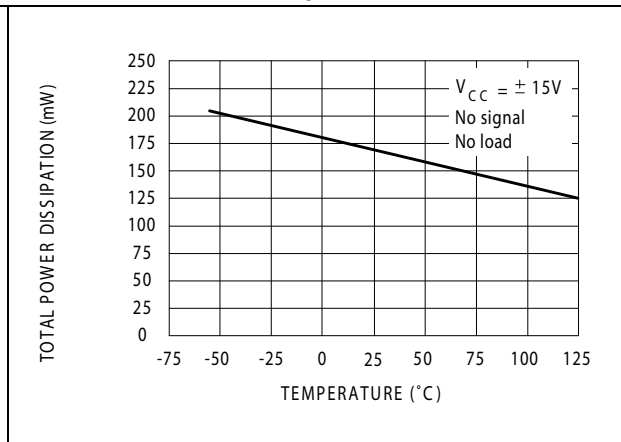

Figure 12. Supply current per amplifier versus free air temperature

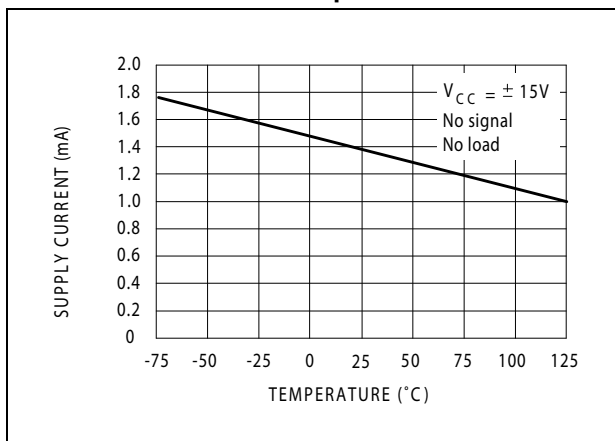

Figure 13. Common mode rejection ratio versus free air temperature

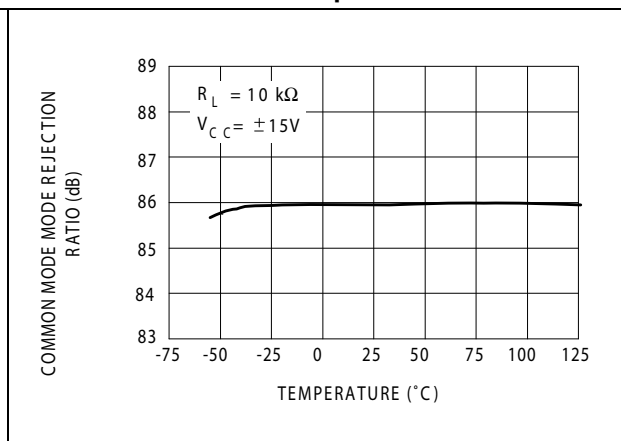

Figure 14. Voltage follower large signal pulse response

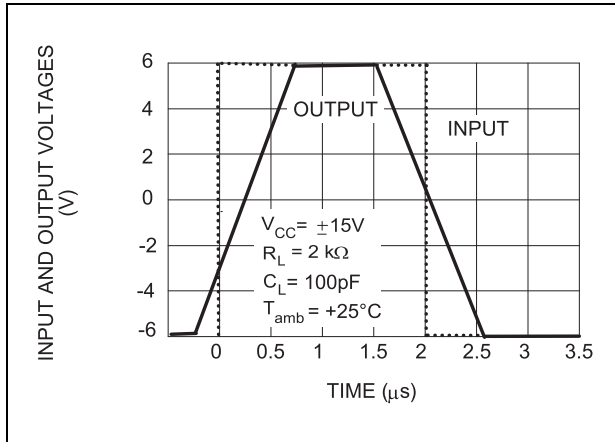

Figure 15. Output voltage versus elapsed time

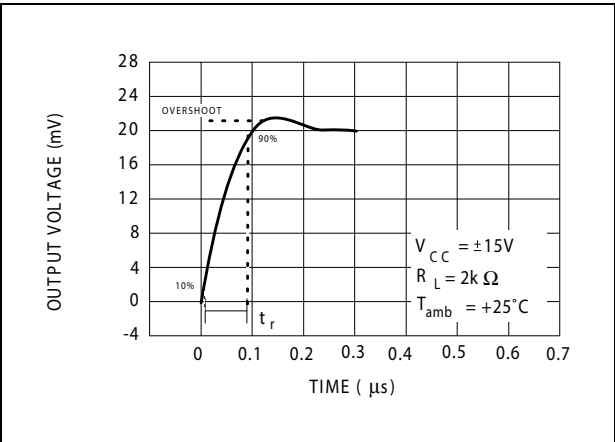

Figure 16. Equivalent input noise voltage versus frequency

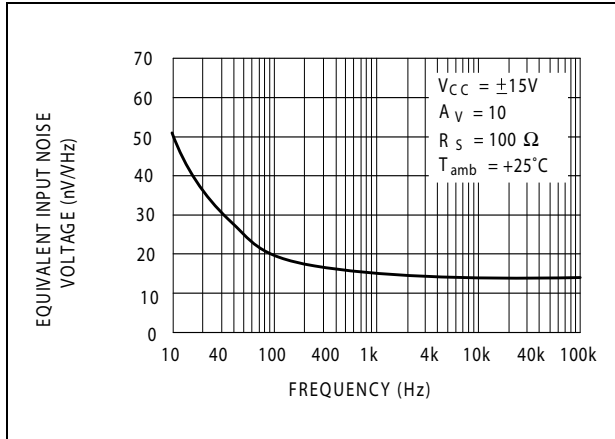
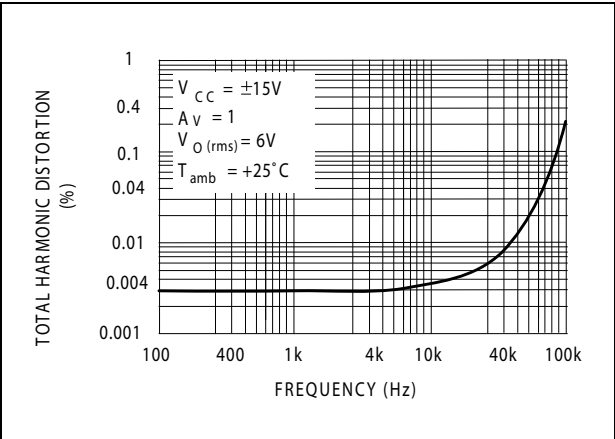

Figure 17. Total harmonic distortion versus frequency



4 Parameter measurement information

Figure 18. Voltage follower

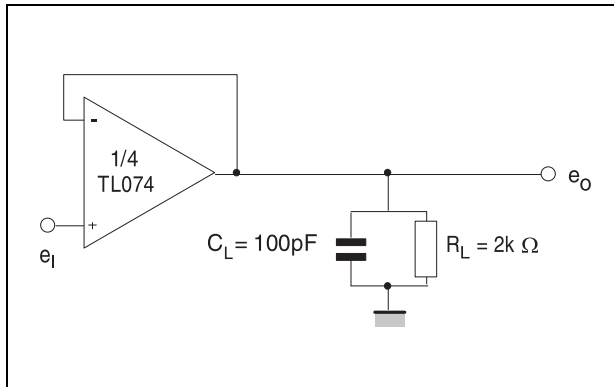
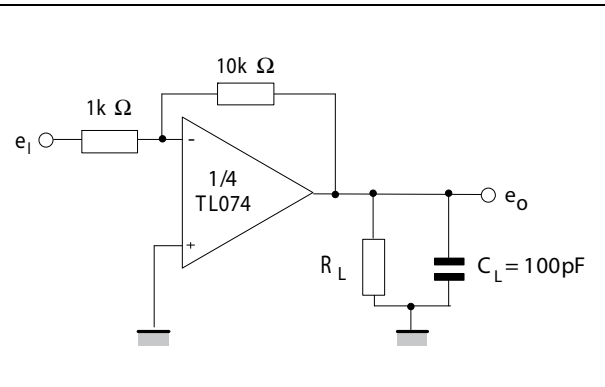

Figure 19. Gain-of-10 inverting amplifier



5 Typical applications

Figure 20. Audio distribution amplifier

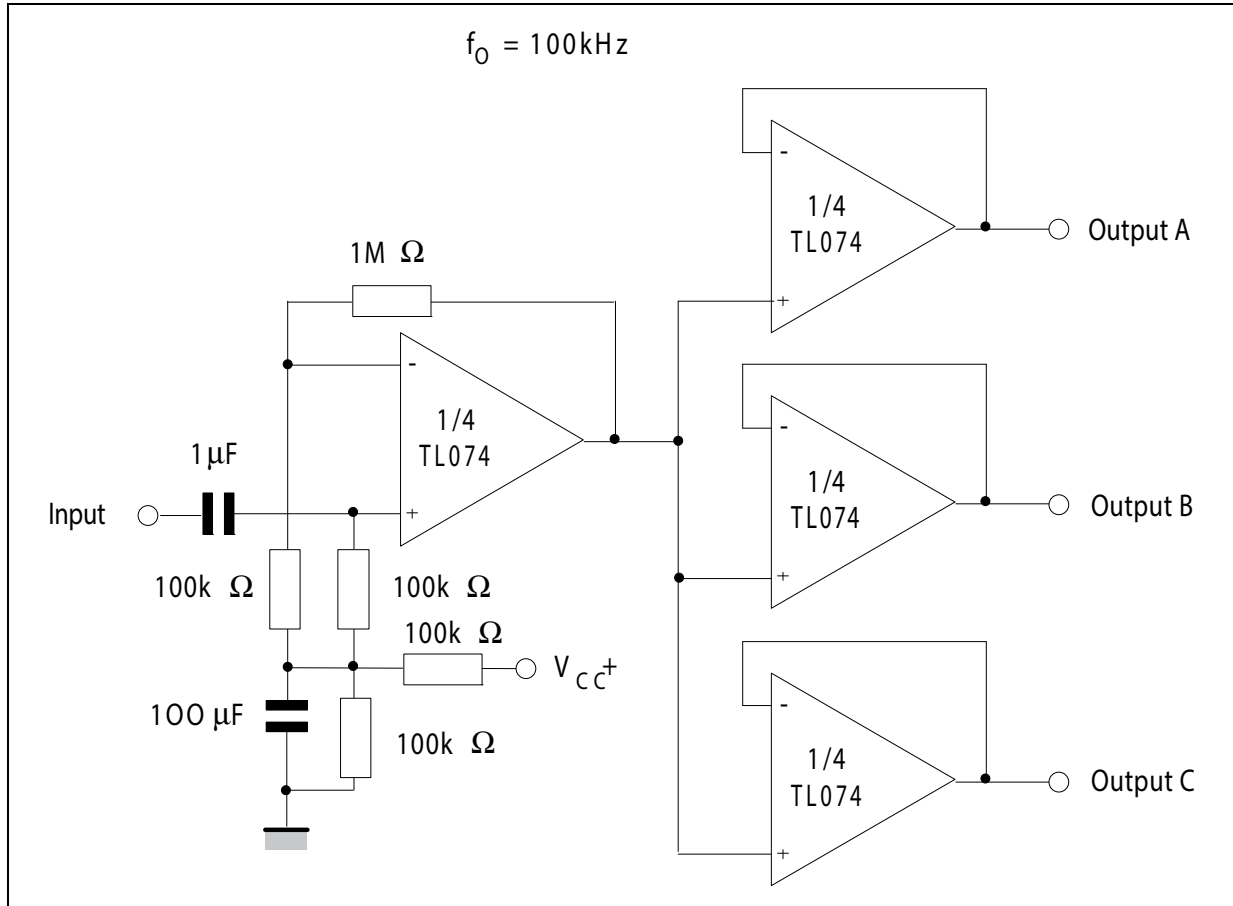

Figure 21. Positive feedback bandpass filter

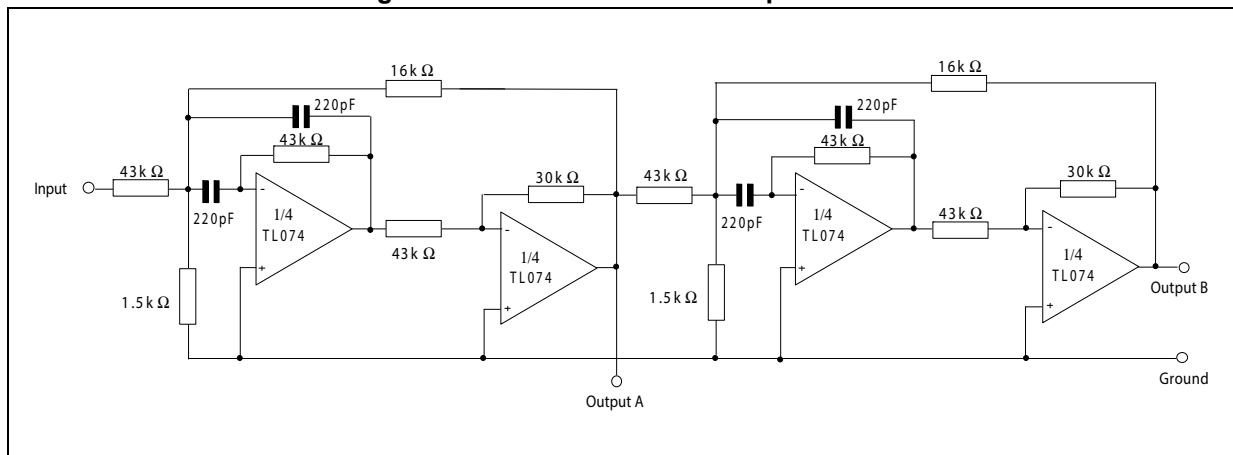
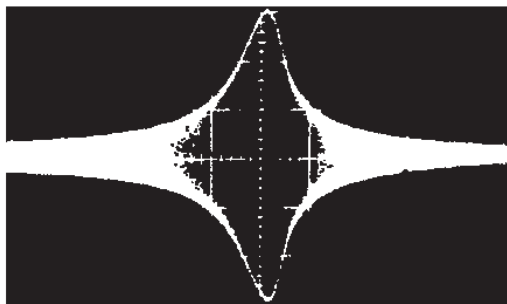
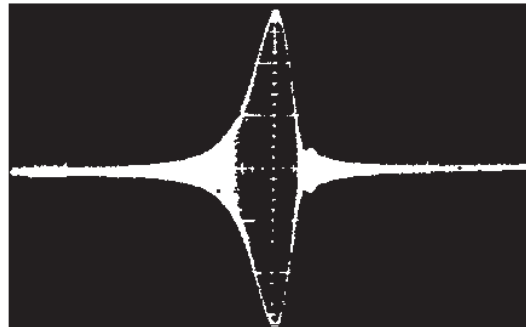

Figure 22. Output A



SECOND ORDER BANDPASS FILTER
fo = 100 kHz; Q = 30; Gain = 16

Figure 23. Output B



CASCADED BANDPASS FILTER
fo = 100 kHz; Q = 69; Gain = 16

6 Package information

In order to meet environmental requirements, ST offers these devices in different grades of ECOPACK® packages, depending on their level of environmental compliance. ECOPACK® specifications, grade definitions and product status are available at: www.st.com. ECOPACK is an ST trademark.

6.1 SO14 package information

Figure 24. SO14 package mechanical drawing

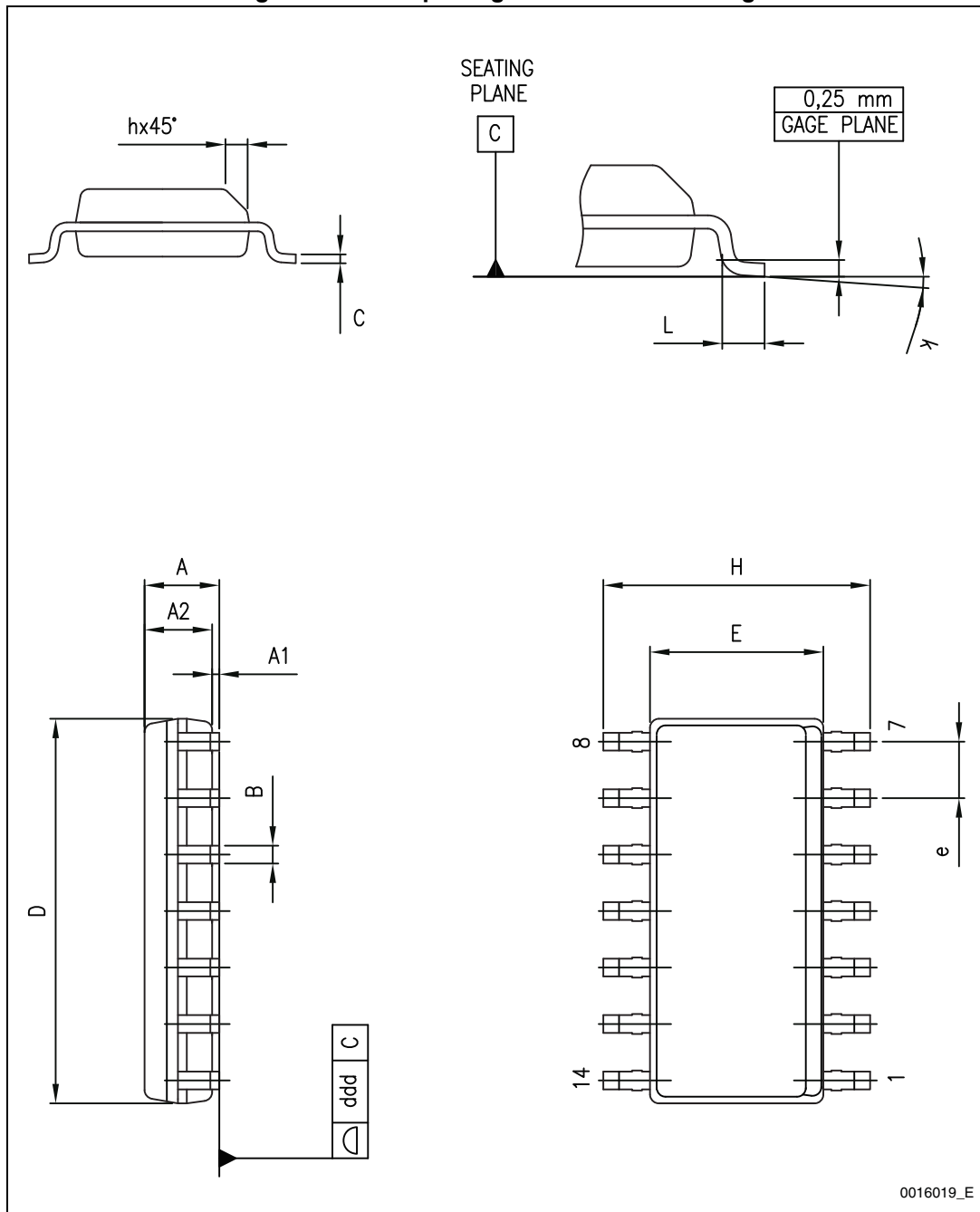

Table 4. SO14 package mechanical data

Dimensions						
Ref.	Millimeters			Inches		
	Min.	Typ.	Max.	Min.	Typ.	Max.
A	1.35		1.75	0.05		0.068
A1	0.10		0.25	0.004		0.009
A2	1.10		1.65	0.04		0.06
B	0.33		0.51	0.01		0.02
C	0.19		0.25	0.007		0.009
D	8.55		8.75	0.33		0.34
E	3.80		4.0	0.15		0.15
e		1.27			0.05	
H	5.80		6.20	0.22		0.24
h	0.25		0.50	0.009		0.02
L	0.40		1.27	0.015		0.05
k	0 °		8 °	0 °		8 °
e		0.40			0.015	
ddd			0.10			0.004

7 Ordering information

Table 5. Order codes

Order code	Temperature range	Package	Packing	Marking
TL074IDT TL074AIDT TL074BIDT	-40°C, +125°C	SO14	Tape and reel	074I
				074AI
				074BI
TL074IYDT ⁽¹⁾ TL074AIYDT ⁽¹⁾ TL074BIYDT ⁽¹⁾				074IY
				074AIY
				074BIY
TL074CDT TL074ACDT TL074BCDT	0°C, +70°C			074C
				074AC
				074BC

1. Qualified and characterized according to AEC Q100 and Q003 or equivalent, advanced screening according to AEC Q001 & Q 002 or equivalent.

8 Revision history

Table 6. Document revision history

Date	Revision	Changes
28-Mar-2001	1	Initial release.
30-Jul-2007	2	Added values for R_{thja} , R_{thjc} and ESD in Table 1: Absolute maximum ratings . Added Table 2: Operating conditions . Expanded Table 5: Order codes . Format update.
07-Jul-2008	3	Removed information concerning military temperature ranges (TL074Mx, TL074AMx, TL074BMx). Added automotive grade order codes in Table 5: Order codes .
04-Jul-2012	4	Removed commercial types TL074IYD, TL074AIYD, TL074BIYD. Updated Table 5: Order codes .
22-Nov-2013	5	Added Related products on first page Removed DIP package mechanical information Table 5: Order codes : – removed commercial types related to DIP package: TL074IN, TL074AIN, TL074BIN, TL074CN, TL074ACN, TL074BCN; – removed commercial types related to tube packing: TL074ID, TL074AID, TL074BID, TL074CD, TL074ACD, TL074BCD; – changed operating temperature range for TL074IDT, TL074AIDT, TL074BIDT, TL074IYDT, TL074AIYDT, TL074BIYDT from -40 °C, +105 °C to -40 °C, +125 °C; – updated footnote for automotive parts.