

Voltage-mode boost to ground evaluation kit

TLD5099EP

About this document

Product description

The TLD5099EP is an AEC qualified DC-DC boost controller, especially designed to drive LEDs.

- Built in diagnosis and protection features
- Pulse width modulator to implement a dimming function with reduced color shifting
- Spread spectrum modulator to improve the EMI performance

Scope and purpose

Scope of this user manual is to provide instructions on the use of TLD5099EP voltage-mode boost to ground evaluation board.

Intended audience

This document is intended for engineers who need to perform measurements and check performances with TLD5099EP voltage-mode boost to ground evaluation board.

Table of contents

	About this document	1
	Table of contents	1
1	Description	2
2	Quick start procedure	4
3	Auto-enable configuration	5
4	Schematics	6
5	PCB layout	8
6	Bill of material	9
7	Efficiency measurements	10
8	Maximizing efficiency	11
9	Minimizing EM emissions	12
	Revision history	13
	Disclaimer	14

1 Description

1 Description

The Evaluation board for medium power application with TLD5099EP configured in voltage-mode boost to ground topology will be explained. It can be implemented as a DC-DC power supply with constant voltage output.

The default configuration of the board is voltage-mode boost to ground topology without any additional features enabled. In this configuration, it can deliver up to 17 W to the load with an efficiency above 91%.

Note: The board is not protected against output short circuits. If protection is needed, place a 500 mA fast blow fuse in series with the positive power output terminal.

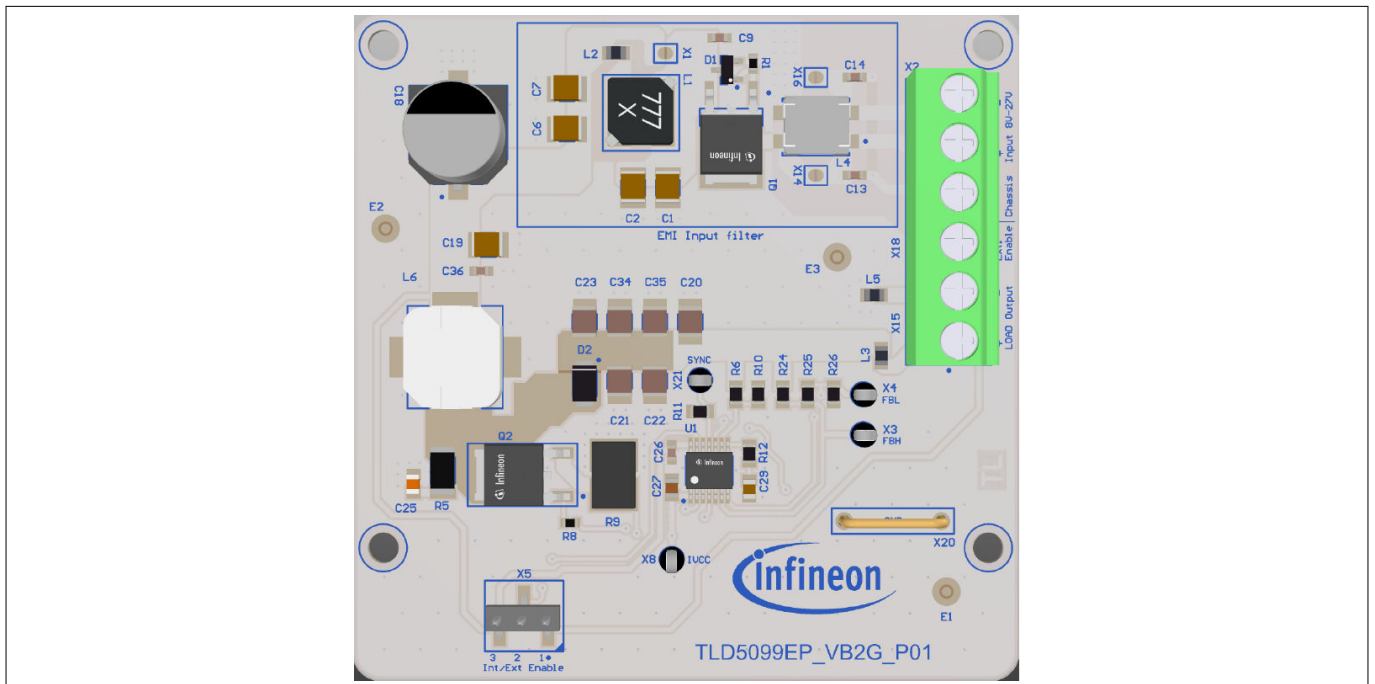

Figure 1 Board picture

1 Description

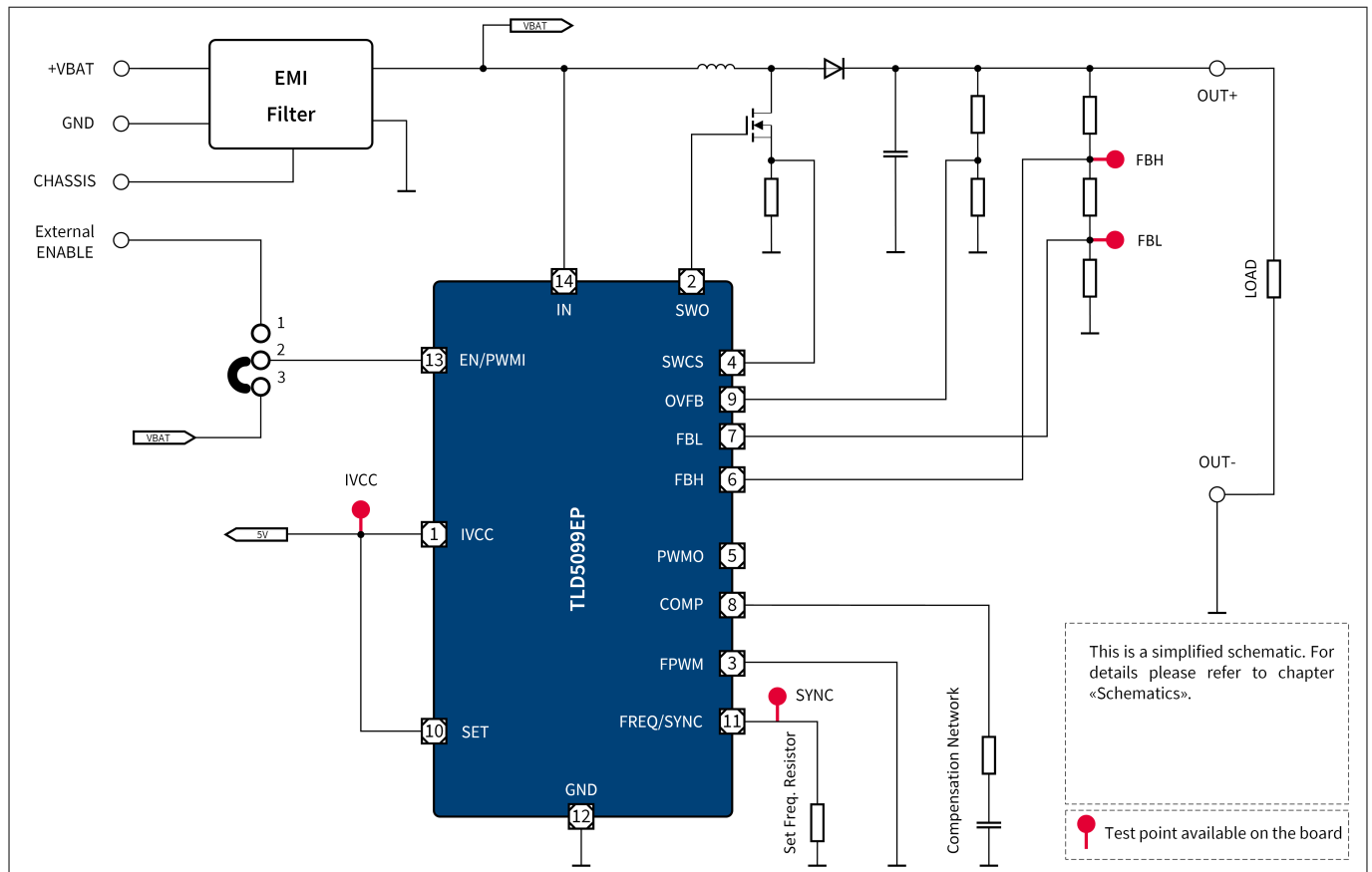

Figure 2 Simplified schematic

Table 1 Performance summary

Parameter	Conditions	Value
Input supply voltage	Parameter degradation below 6.5 V	8 V to 27 V Down to 6.5 V for less than 2 s
Maximum output current	Resistive load	350 mA
Switching frequency	$V_{IN} = 13.2 \text{ V}$	400 kHz
Efficiency	Measured with a 139 Ω power resistor as load	> 91%
Output voltage range	Output voltage related to ground	48 V
Output overvoltage protection	Output voltage related to ground	60 V

2 Quick start procedure

2 Quick start procedure

The default configuration of the board has all additional features disabled. The jumper is placed in position 1-2. In this configuration the ENABLE signal must be applied on X18 (max. 45 V). If another output voltage is required, change the values of the voltage divider resistors R24, R25, and R26 according to the following equation:

$$\frac{V_{OUT}}{R24 + R25 + R26} \cdot R25 = V_{REF} \tag{1}$$

where V_{OUT} is the desired output voltage and $V_{REF} = 300\text{ mV}$ is the feedback reference voltage. Correct device functioning is achieved if voltages V_{FBH} and V_{FBL} on both terminals of R25 are greater than 3 V with respect to ground.

Attention: *On this board V_{OUT} is set to 48 V by default. Increasing V_{OUT} over the default level may damage some components irreversibly.*

The default configuration is depicted below:

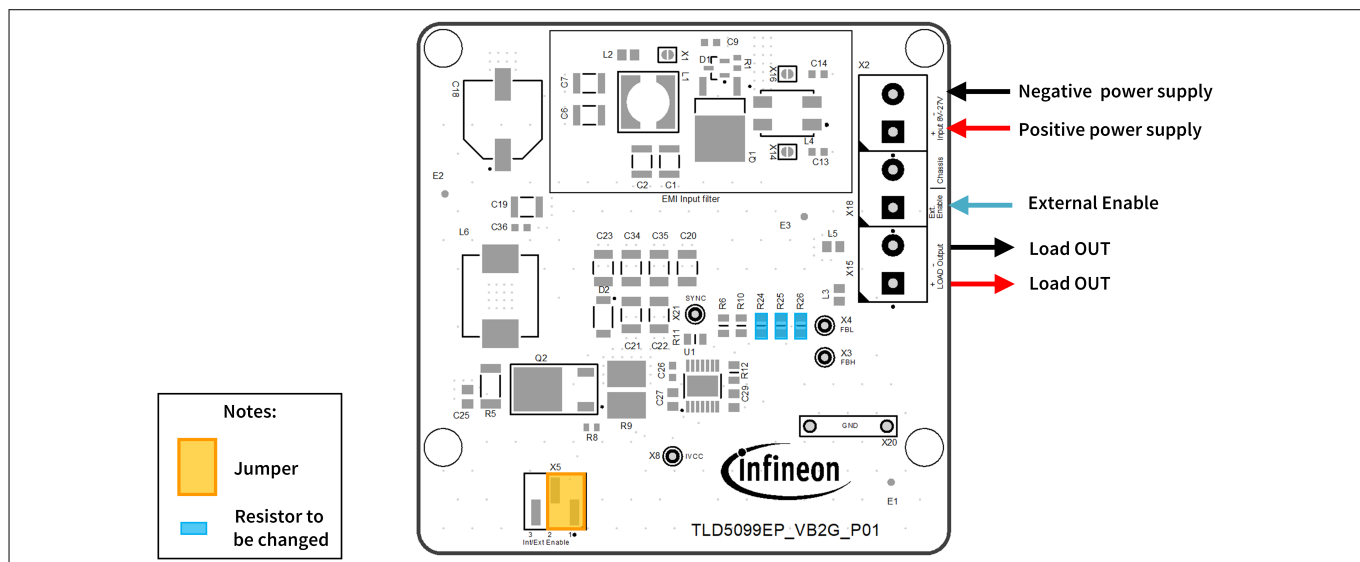

Figure 3 **Default configuration of the board**

3 Auto-enable configuration

3 Auto-enable configuration

By placing the jumper X5 on position 2-3, the device starts without any external enable signal because pin EN (ENABLE) is connected directly to the positive rail (see [Schematics](#) for details).

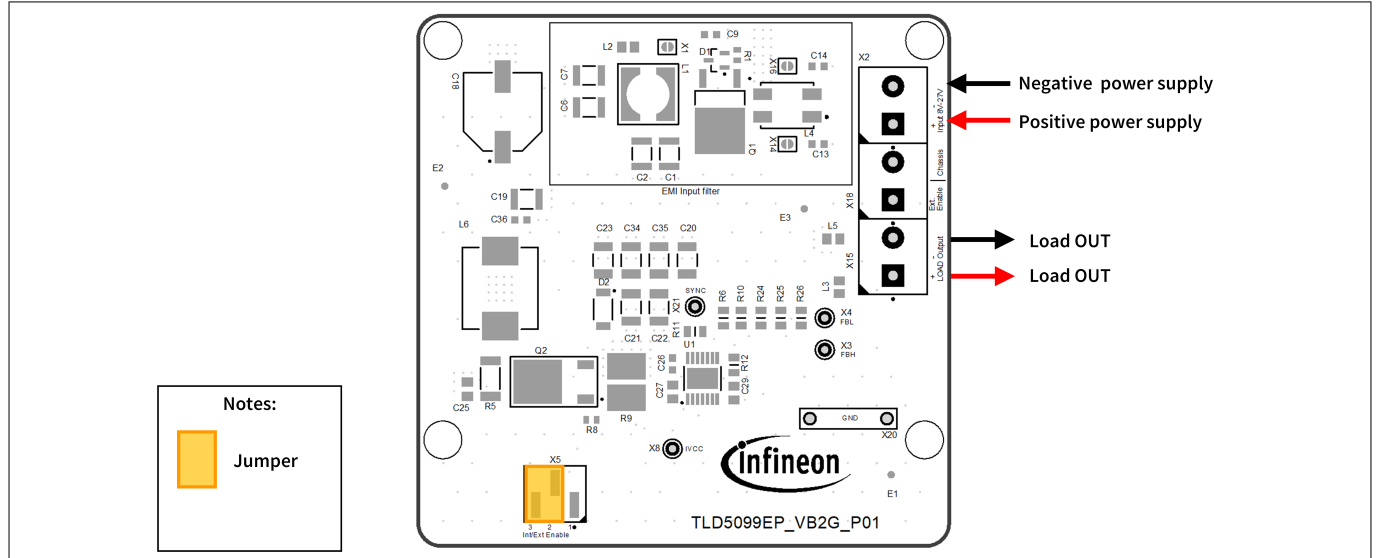

Figure 4 Auto-enable configuration

4 Schematics

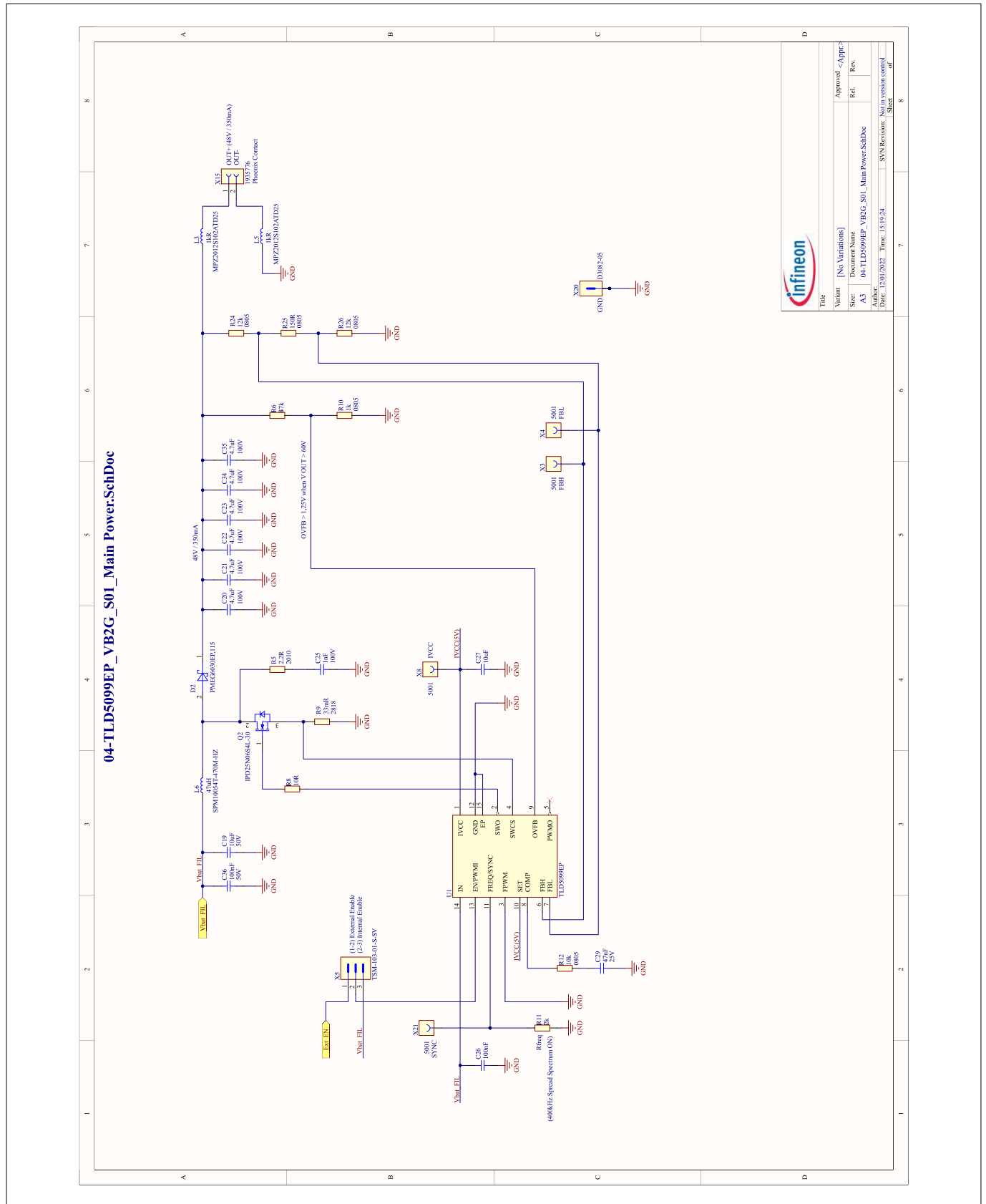

Figure 6 Main power

5 PCB layout

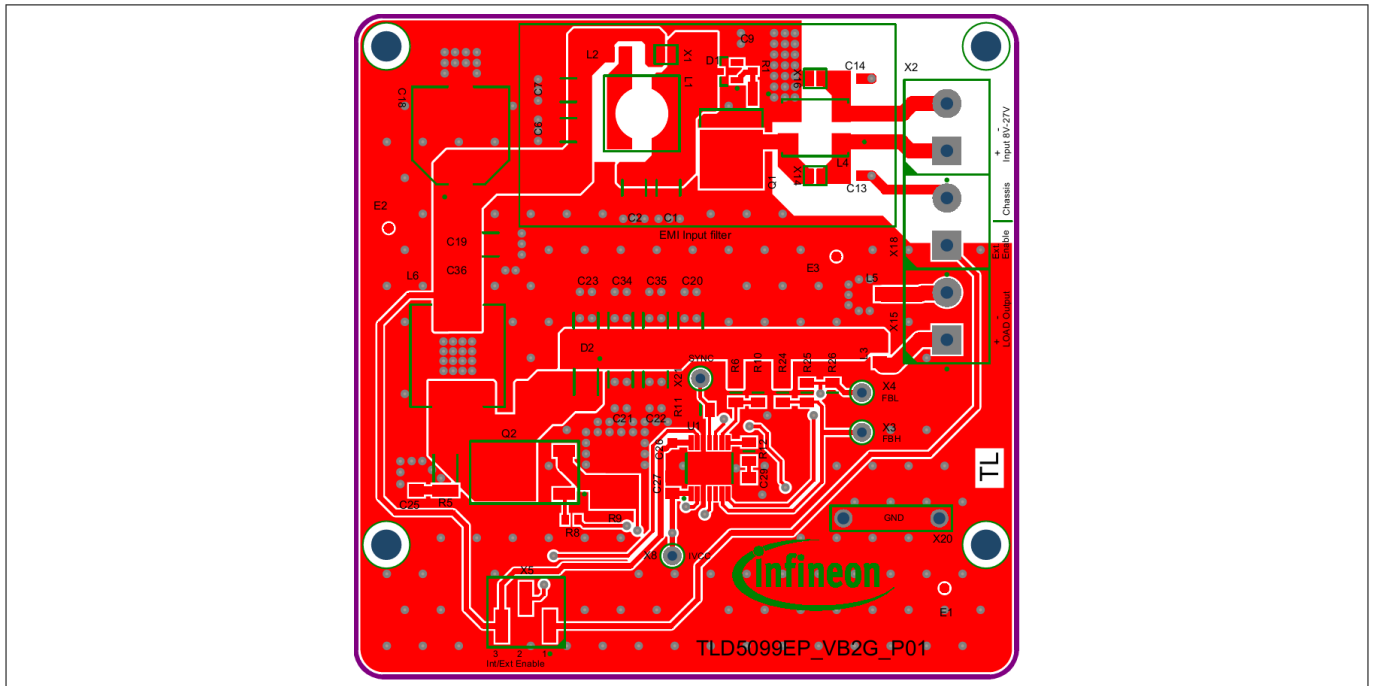

Figure 7 PCB layout top view

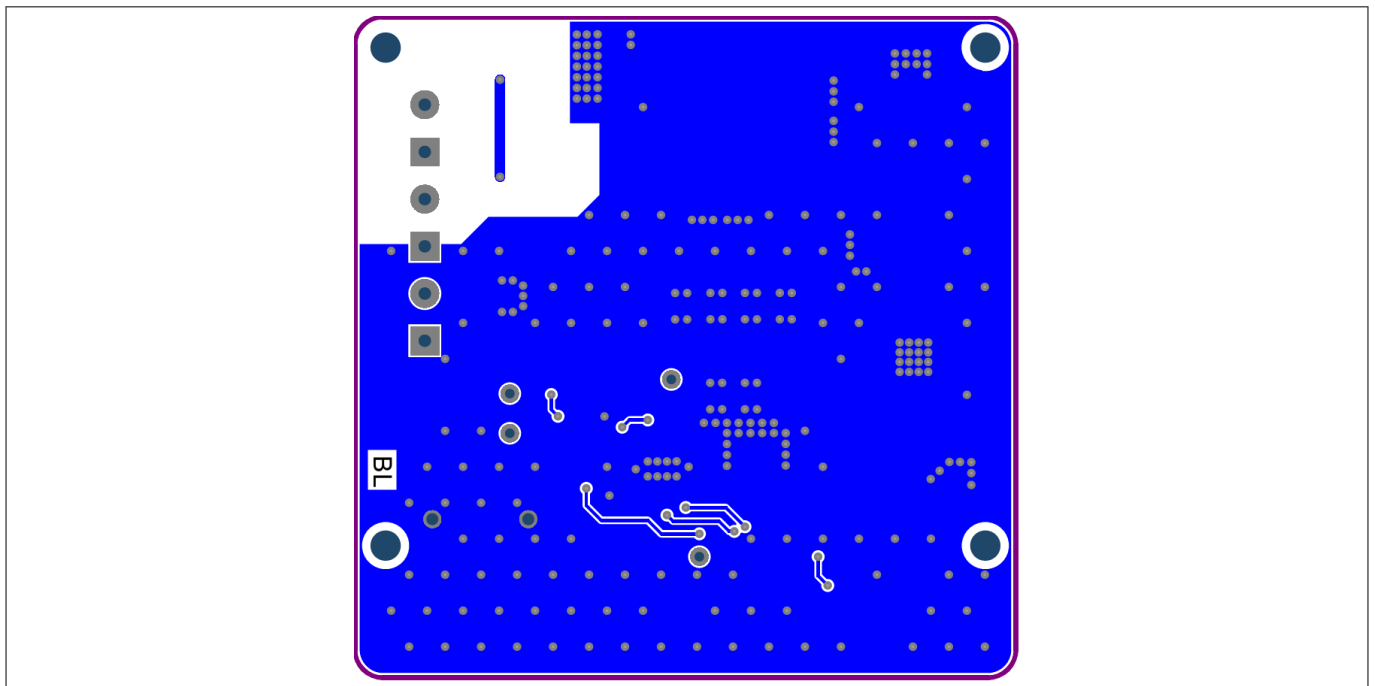

Figure 8 PCB layout bottom view

6 Bill of material

6 Bill of material

Table 2 Bill of material

Designator	Value	Manufacturer	Manufacturer order number
C1, C2, C6, C7, C19	10 uF	Murata	GCM32EC71H106KA03
C9, C26, C36	100 nF	AVX	06035C104K4Z2A
C13, C14	470 pF	Murata	GCM1885C1H471JA16
C18	220 uF	Panasonic	EEEFK1H221P
C20, C21, C22, C23, C34, C35	4.7 uF	TDK	CGA6M3X7S2A475K200AE
C25	1 nF	TDK	CGA4F2X7R2A102M085AE
C27	10 uF	TDK	CGA4J1X7S1C106K125AC
C29	47 nF	Kemet	C0805C473J3GACAUTO
D1	10 V	ON Semiconductor	BZX84C10LT1G
D2	PMEG6030EP,115	Nexperia	PMEG6030EP,115
L1	3.3 uH	Coilcraft	MSS7341T-332NL
L2	100 Ω @ 100 MHz	TDK	MPZ2012S101ATD25
L3, L5	1 kΩ @ 100 MHz	TDK	MPZ2012S102ATD25
L4	–	TDK	ACM70V-701-2PL-TL00
L6	47 uH	TDK	SPM10054T-470M-HZ
Q1	IPD90P04P4L-04	Infineon Technologies	IPD90P04P4L-04
Q2	IPD25N06S4L-30	Infineon Technologies	IPD25N06S4L-30
R1	10 kΩ	Vishay	CRCW060310K0FK
R5	2.2 Ω	Vishay	CRCW20102R20FK
R6	47 kΩ	Vishay	CRCW080547K0FK
R8	10 Ω	Vishay	CRCW060310R0FK
R9	33 mΩ	Vishay	WSHM2818R0330FEA
R10	1 kΩ	Vishay	CRCW08051K00FK
R11	2 kΩ	Vishay	CRCW08052K00FK
R12	10 kΩ	Vishay	CRCW080510K0FK
R24, R26	12 kΩ	Vishay	CRCW080512K0FK
R25	150 Ω	Vishay	CRCW0805150RFK
U1	TLD5099EP	Infineon Technologies	TLD5099EP
X1, X14, X16	Solder Jumper 2 Pins	–	Solder Jumper 2 Pins
X2, X15, X18	1935776	Phoenix Contact	1935776
X3, X4, X8, X21	5001	Keystone	5001
X5	TSM-103-01-S-SV	Samtec	TSM-103-01-S-SV
X20	D3082-05	Harwin	D3082-05

7 Efficiency measurements

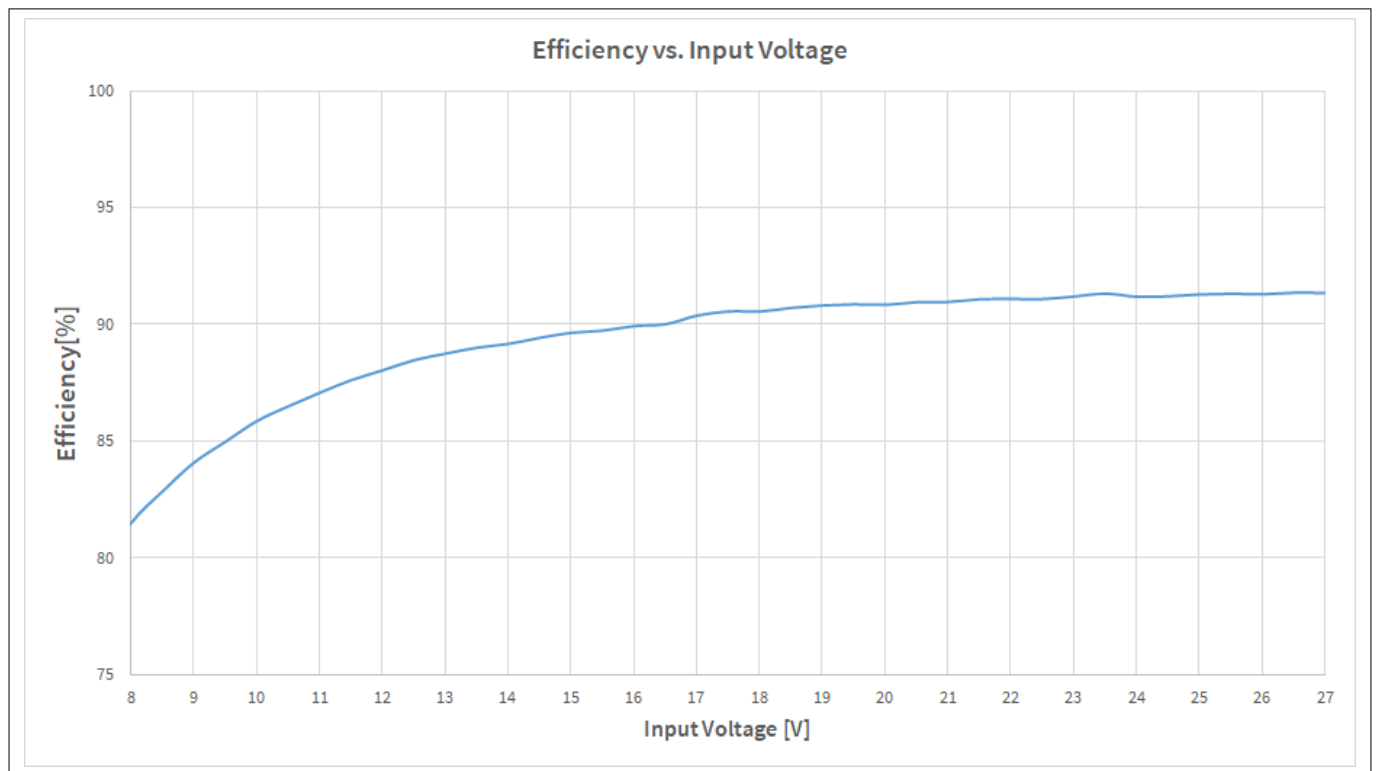

Figure 9 Efficiency vs. input voltage

This efficiency performance has been obtained with:

Table 3 Parameters influencing efficiency

Output load	139 Ω power resistor
EMI filter	Totally bypassed by closing the jumpers X1, X14 and X16

Efficiency performances can be increased, refer to [Maximizing efficiency](#).

8 Maximizing efficiency

This evaluation board has been designed to reach a fair compromise between efficiency performance and EM emissions compliance.

Nevertheless, if the maximum efficiency is needed, the following actions are suggested:

- 1.** Remove the snubber circuit consisting of R5 and C25 or choose a lower value for the capacitor C25 (for example 470 pF)
- 2.** Bypass the whole EMI filter by bridging the jumpers X1, X14 and X16
- 3.** Bypass the output ferrite beads L3 and L5
- 4.** Replace the main inductor L6 with one that boasts a lower parasitic DC resistance, for example
 - Vishay IHLP6767GZER470M8A
 - Bourns SRP1770TA-470M
- 5.** Bypass gate resistor R8

9 Minimizing EM emissions

This evaluation board has been designed to reach a fair compromise between efficiency performance and EM emissions compliance. Furthermore, this evaluation board can fulfill the class V of the CISPR25 in conducted emissions from 150 kHz to 108 MHz.

Nevertheless, if the minimum EM emission is required, the following actions should be considered:

1. Choose a higher value for the capacitor C25 (for example 2.2 nF)
2. Include the whole EMI filter by removing bridges from the jumpers X1, X14 and X16
3. Replace the 10 Ω resistor R8 with a higher value such as 22 Ω or 33 Ω
4. Replace the main inductor L6 with a shielded one (for example the Cyntec VCHE106G-470MS6) and connect the shield to ground
5. With a short piece of wire connect the CHASSIS TERMINAL to the test ground plane as close as possible to where the board is placed

Revision history

Revision history

Document version	Date of release	Description of changes
Rev.2.00	2022-02-04	Second release related to evalboard S01_P01 <ul style="list-style-type: none">• Editorial changes and rephrasing for clarity• Updated all figures• Rearranged connectors on evalboard• Added ground bar on evalboard
Rev.1.00	2020-01-29	First release related to evalboard S00_P00