

# Accurate 2-wheeler motor control

## With XENSIV™ magnetic current sensors

Rising standards of living, a growing awareness of the need to conserve limited natural resources, and the effects of global warming are driving a shift from mechanical to electronic control systems in small conventional vehicles such as bicycles and motorcycles. This trend is apparent worldwide, especially in emerging markets. In addition, demand for small electric vehicles such as electric-powered bicycles (e-bikes and pedelecs) is growing around the world.

Increasingly strict emissions legislation in many countries is also driving demand for efficiency-enabling semiconductor solutions in the small 1- to 2-cylinder combustion engine segment. Looking beyond standard carburetors, customers are increasingly looking for more electrified solutions. As the market leader in automotive electronics, Infineon is ideally positioned to meet growing needs for fuel-efficient solutions through a wide range of microcontrollers, sensors, power supplies, transceivers, driver ICs, MOSFETs, IGBTs, as well as fully integrated U-chip solutions.

### Key features

- Low total error over temperature and lifetime
- Sensitivity drift over temperature down to 0.8% (-40°C to 150°C)
- Low phase shift at motor current frequency and high bandwidth
- Low power dissipation
- Easy integration and small package options
- Programmable measurement range
- ISO 26262-compliant development

## XENSIV™ current sensors in 2-wheeler inverter architecture

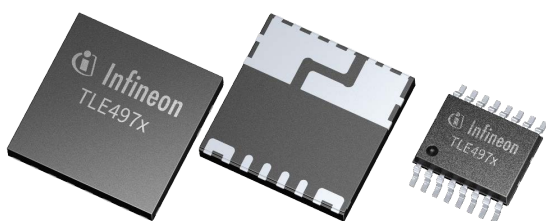
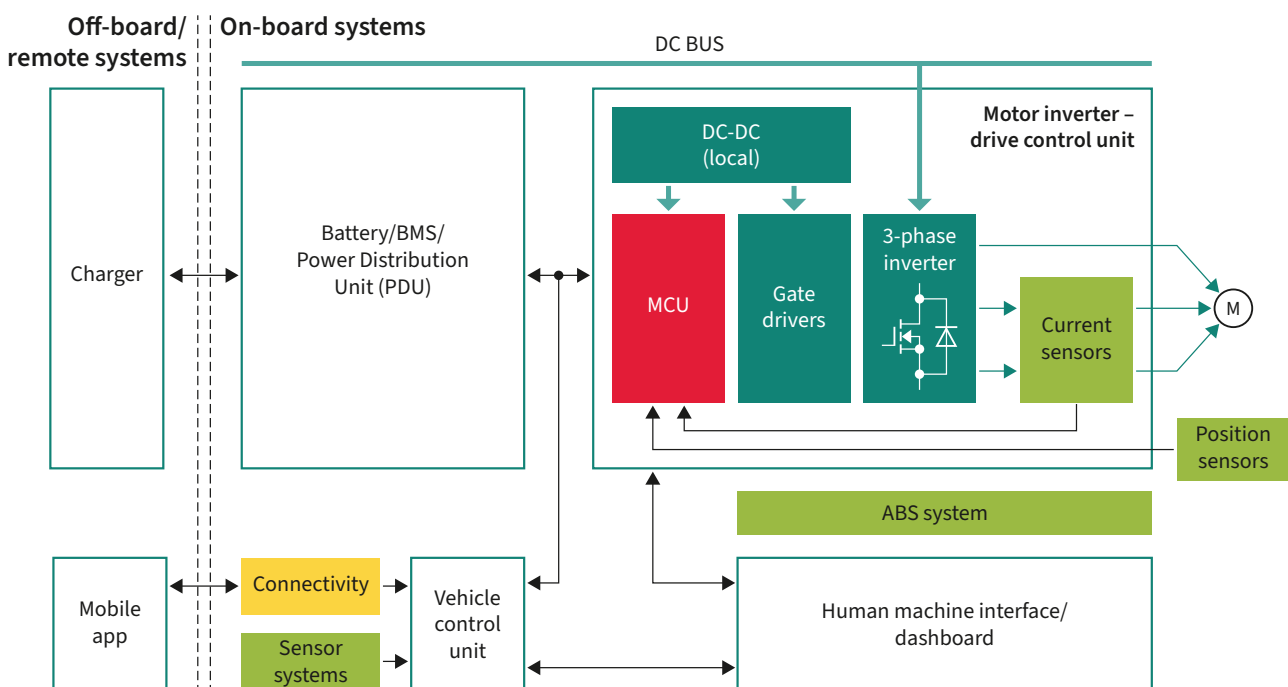

## APPLICATION BRIEF

The 2-wheeler industry requires current sensing solutions that combine optimal torque control with adaptability to different mechanical design and power classes. To reduce overall system size, inverters for e-scooters must enable higher levels of power density. An in-phase current sensor helps to provide the current information for motor commutation with Field Oriented Control (FOC) techniques.

XENSIV™ current sensors are exceptionally precise and stable over temperature and lifetime thanks to industry-leading Hall-based magnetic technology. They also come with a digitally assisted analog signal path, which enables low total error behavior over temperature and lifetime. In addition, the high bandwidth and low insertion resistance achievable in combination with typical sensing structures makes XENSIV™ the perfect choice for accurate and efficient torque control.

XENSIV™ current sensors offer a compact solution to sense the current flowing in an external conductor (busbar or PCB track). Bulky core-based sensors can be easily replaced by a small SMD

device. The two package variants give system integrators high flexibility, requiring only 3.5 x 4.5 mm or 6 x 5 mm of space for VSON and TDSO packages respectively.

ISO 26262-compliant development and safety documentation allow for ratings up to ASIL B.

We work with external partners in order to provide system-level solutions. Current sensing modules based on XENSIV™ current sensors with 2<sup>nd</sup> level overmolding have been developed to ease integration into any inverter solution.

With a wide-ranging magnetic sensor portfolio, Infineon is the perfect partner to meet future market requirements. To learn more about current sensing in automotive inverters, have a look at our [whitepapers](#) and [application notes](#) available for download at [www.infineon.com/current-sensors](http://www.infineon.com/current-sensors).

Learn more about our solutions for light vehicles at [link to](#)

### XENSIV™ current sensors integration possibilities

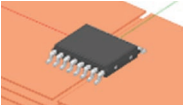
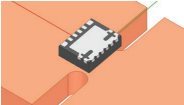
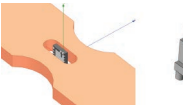
Lateral insertion		Vertical insertion
PCB	Busbar	Busbar
		
TDSO/VSON	VSON/TDSO	VSON/TDSO
■ Up to 500 A	■ Up to 2kA	

### XENSIV™ current sensors sensing module (Partner: Swoboda)



Product name	Ordering code	Description
TLE4972-AE35D5	SP004914362	3.3 V high precision current sensor based on Hall technology in a TDSO-16 package
TLE4972-AE35S5	SP004914370	3.3 V high precision current sensor based on Hall technology in a VSON-6 package
TLE4973-AE35D5-S0001	SP005353128	5 V high precision current sensor based on Hall technology in a TDSO-16 package, semi-differential output mode
TLE4973-RE35D5-S0001	SP005448166	5 V high precision current sensor based on Hall technology in a TDSO-16 package, semi-differential output mode
TLE4973-RE35D5-S0010	SP005448161	5 V high precision current sensor based on Hall technology in a TDSO-16 package, single-ended AOUT only
TLE4973-AE35S5-S0001	SP005353131	5 V high precision current sensor based on Hall technology in a VSON-6 package, semi-differential output mode
TLE4973-RE35S5-S0001	SP005448267	5 V high precision current sensor based on Hall technology in a VSON-6 package, semi-differential output mode
TLE4973-RE35S5-S0010	SP005448259	5 V high precision current sensor based on Hall technology in a VSON-6 package, single-ended AOUT only



[www.infineon.com](http://www.infineon.com)

Published by  
Infineon Technologies AG  
Am Campeon 1-15, 85579 Neuburg  
Germany

© 2023 Infineon Technologies AG  
All rights reserved.

Public

Date: 06 / 2023

#### Please note!

This Document is for information purposes only and any information given herein shall in no event be regarded as a warranty, guarantee or description of any functionality, conditions and/or quality of our products or any suitability for a particular purpose. With regard to the technical specifications of our products, we kindly ask you to refer to the relevant product data sheets provided by us. Our customers and their technical departments are required to evaluate the suitability of our products for the intended application.

We reserve the right to change this document and/or the information given herein at any time.

#### Additional information

For further information on technologies, our products, the application of our products, delivery terms and conditions and/or prices, please contact your nearest Infineon Technologies office ([www.infineon.com](http://www.infineon.com)).

#### Warnings

Due to technical requirements, our products may contain dangerous substances. For information on the types in question, please contact your nearest Infineon Technologies office.

Except as otherwise explicitly approved by us in a written document signed by authorized representatives of Infineon Technologies, our products may not be used in any life-endangering applications, including but not limited to medical, nuclear, military, life-critical or any other applications where a failure of the product or any consequences of the use thereof can result in personal injury.