

OPTIREG™ linear TLS715B0NAV50 demoboard

Z8F57824784

Preface

Scope and purpose

This document describes the usage of the OPTIREG™ linear TLS715B0NAV50 demoboard for the TLS715B0NAV50 from Infineon Technologies AG. Please also refer to the corresponding datasheet.

Intended audience

This document is intended for engineers who develop applications.

Table of contents

	Preface	1
	Table of contents	1
1	Introduction	2
1.1	General description	2
1.2	Features TLS715B0NAV50	2
1.3	Block diagram	3
2	Demoboard	4
2.1	Assembly	4
2.2	Operating conditions	5
2.3	Configuration	5
2.3.1	Enable function	5
2.3.2	Signal adaption	7
3	Schematic and layout	9
3.1	Schematic	9
3.2	Layout	10
4	Bill of material	13
5	Restrictions	14
	Revision history	15
	Disclaimer	16

Introduction

1 Introduction

1.1 General description

The TLS715B0NAV50 is a low dropout linear voltage regulator for an output current up to 150 mA. The device regulates an input voltage of up to 40 V to $V_{Q,nom} = 5\text{ V}$ with a precision of $\pm 2\%$. With a typical quiescent current of 36 μA , the TLS715B0NAV50 is the ideal solution for systems requiring very low operating current, such as those permanently connected to the battery. At an output current below 100 mA the TLS715B0NAV50 features a very low dropout voltage of 180 mV. The dropout region begins at an input voltage of 4.0 V (extended operating range). This makes the TLS715B0NAV50 suitable for automotive systems with start-stop requirements. The enable feature turns the device on or off. The TLS715B0NAV50 requires only a single 1 μF output capacitor to maintain stable regulation. The device is designed for the harsh environment of automotive applications. Output current limitation and overtemperature shutdown are implemented in order to protect the device in case of:

- output short circuit to GND
- overcurrent
- overtemperature

The TLS715B0NAV50 is also suitable for other applications requiring a stable supply voltage of 5 V .

1.2 Features TLS715B0NAV50

- Wide input voltage range from 4.0 V to 40 V
- Output voltage 5 V
- Output voltage accuracy $\pm 2\%$
- Output current up to
- Low current consumption of 36 μA
- Very low dropout voltage of typically 180 mV at 100 mA output current
- Stable with small output capacitor of 1 μF
- Enable
- Overtemperature shutdown
- Output current limitation
- Wide temperature range from -40°C up to 150°C
- Green Product (RoHS compliant)

Introduction

1.3 Block diagram

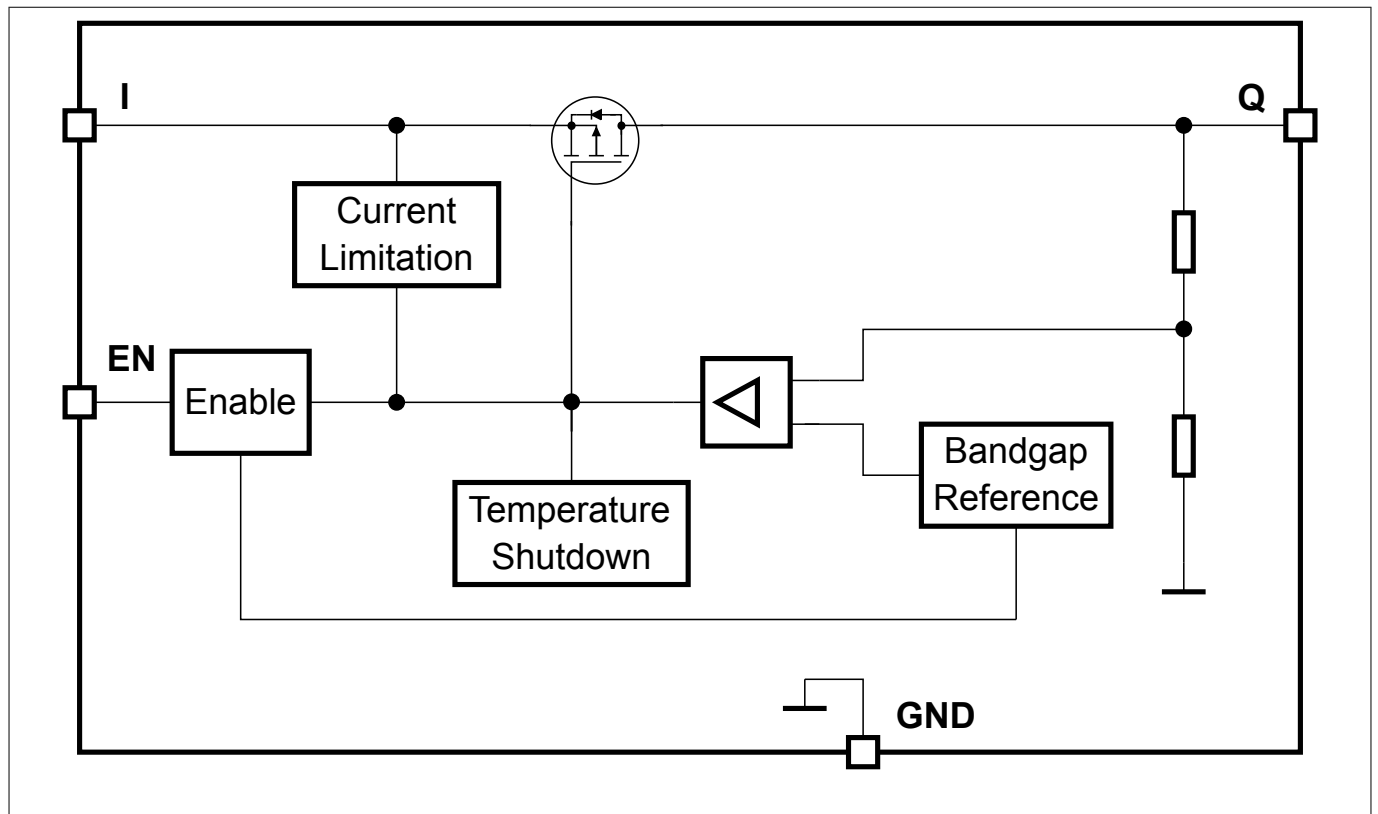

Figure 1 Block diagram TLS715B0NAV50

Demoboard

2 Demoboard

2.1 Assembly

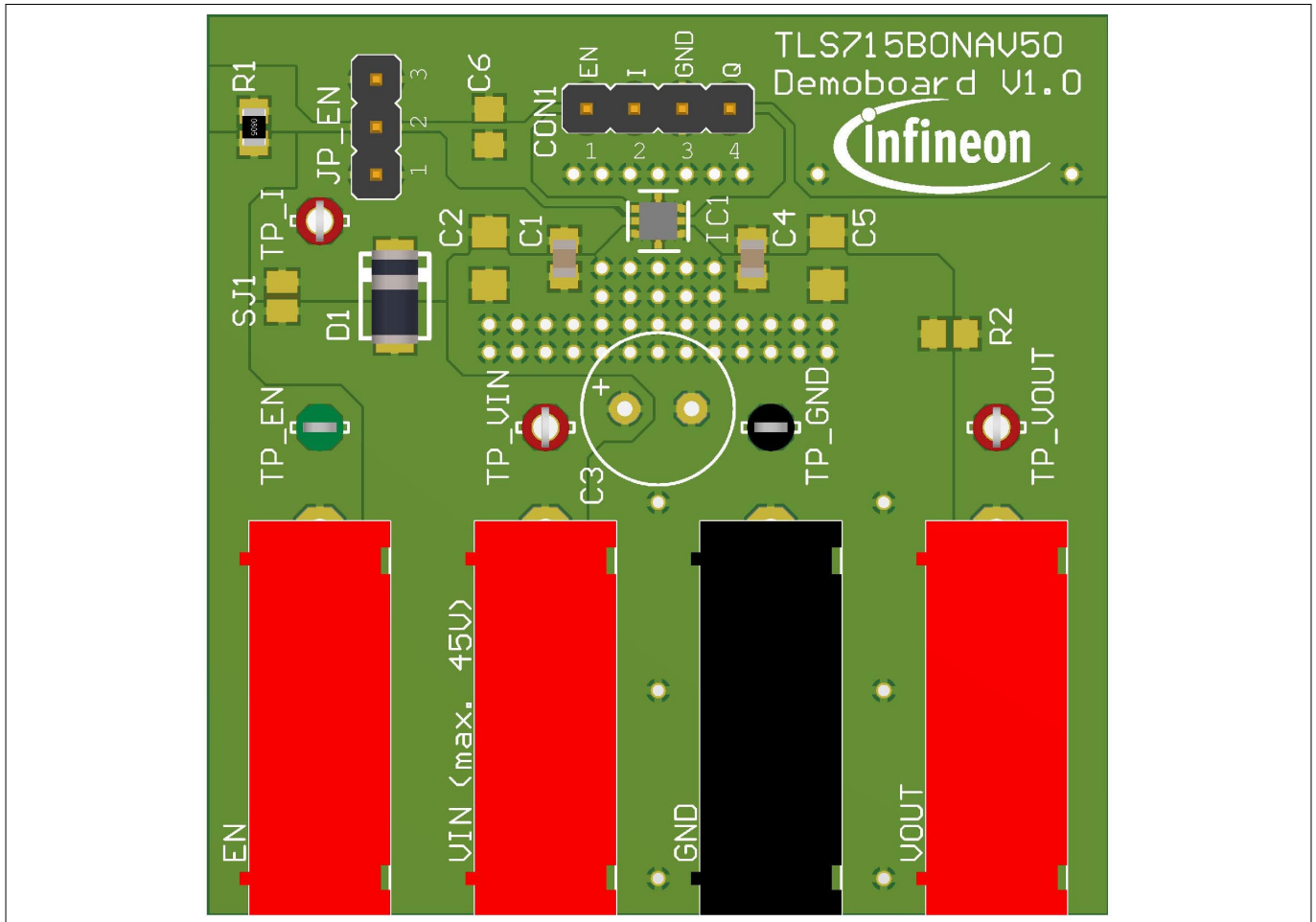

Figure 2 Assembly TLS715B0NAV50 demoboard

Demoboard

2.2 Operating conditions

To avoid electrical damage of the demoboard, the values in [Table 1](#) must be maintained.

Table 1 Operating conditions¹⁾

Parameter	Symbol	Values			Unit	Note or condition
		Min.	Typ.	Max.		
Board supply voltage	V_{IN}	0	–	45	V	²⁾
Regulator output voltage	V_{OUT}	0	–	7	V	–
Enable signal voltage	V_{EN}	0	–	45	V	³⁾
Ground voltage	V_{GND}	0	–	0	V	System GND

2.3 Configuration

The TLS715B0NAV50 demoboard can easily be configured via jumpers. The board provides the following configuration options:

- bypass the reverse protection diode D2 via solder option SJ1
- connect EN input signal to the supply voltage V_{IN} (CON1)
- placeholder for additional input capacitor (C2)
- placeholder for additional output capacitor (C5)
- placeholder for additional bulk input capacitor (C3)
- placeholder for EN-input filter capacitor (C6)

2.3.1 Enable function

The jumper on the pin header JP_EN1 can connect the EN signal to one of the following:

- external source via the corresponding banana jack
- GND
- V_{IN}

[Table 2](#) shows the corresponding jumper options.

¹ $T_A = 25^\circ\text{C}$.

² Functional input voltage range: 4 V to 40 V.

³ Absolute maximum rating.

Demoboard

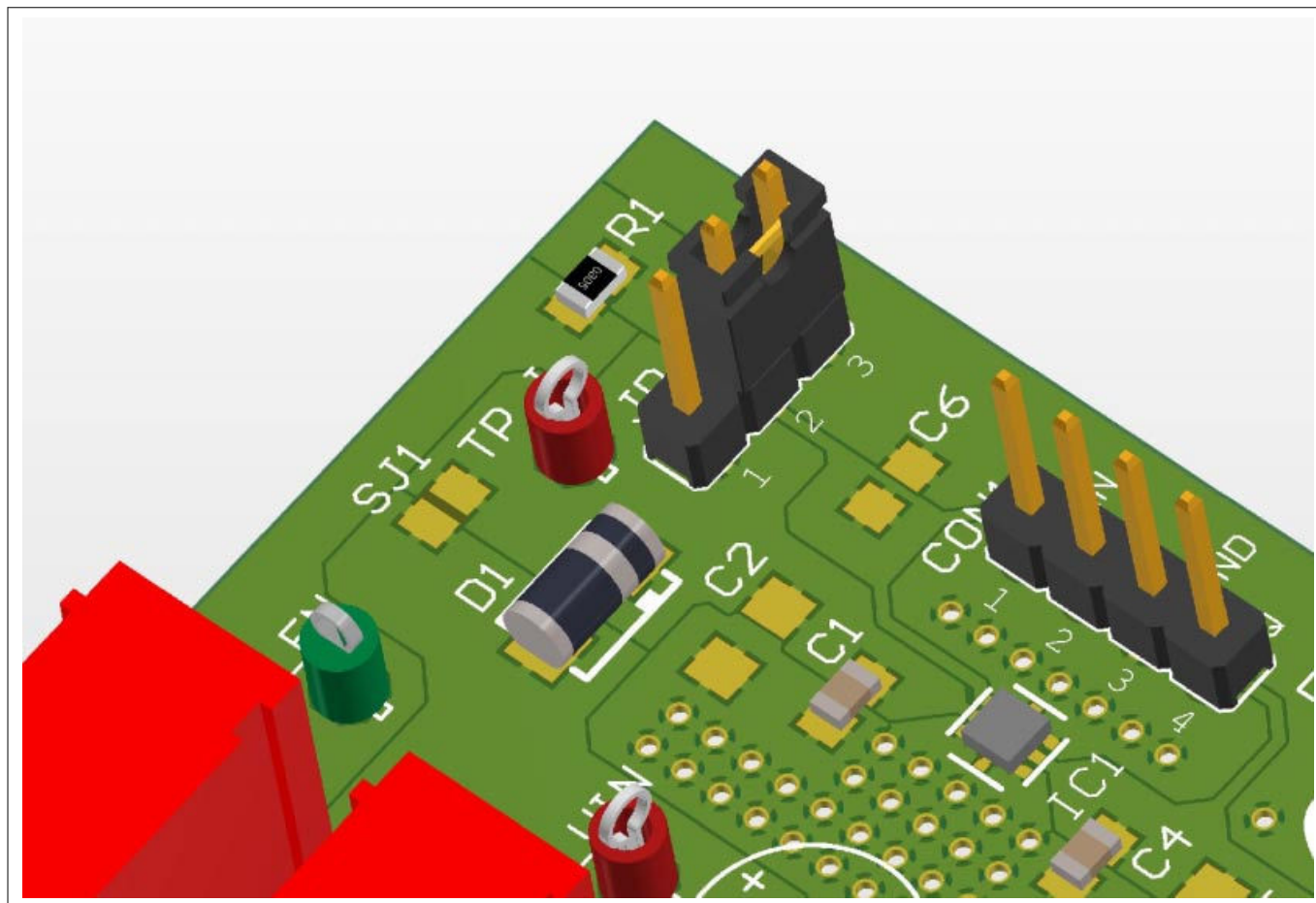

Figure 3 Pin header JP_EN1, short pins 1, 2

Demoboard

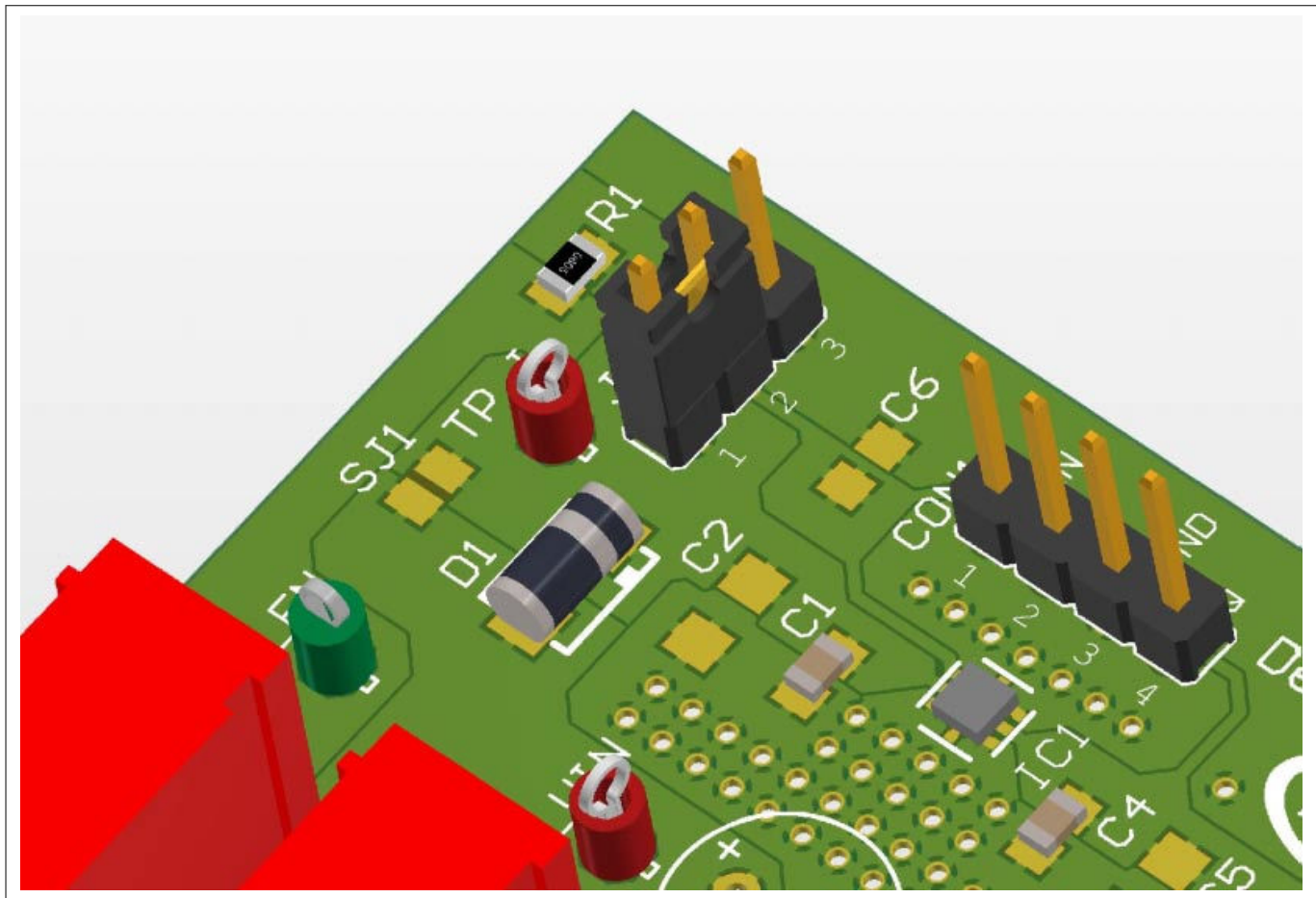

Figure 4 Pin header JP_EN1, short pins 2, 3

Table 2 Pin header JP_EN1 setting

JP_EN1	Enable function
open	EN is connected to the EN banana jack and can be driven by an external source ⁴⁾ . When using long supply leads, then place C6 in this configuration to buffer EN .
Short pins 1, 2	EN is connected to the supply voltage V_{IN} , so the regulator is enabled while supplied.
Short pins 2, 3	EN is shorted to GND, so the regulator remains disabled.

2.3.2 Signal adaption

The demoboard provides connectors for easy signal adaption, for example to connect probes of an oscilloscope.

Table 3 Signals on connector

Connector	Signal
TP_V _{IN}	V_{IN} (input voltage including reverse polarity protection diode)

⁴⁾ When no external signal is applied, then the regulator remains disabled due to the internal pull-down resistor on EN.

Demoboard

Table 3 **Signals on connector (continued)**

Connector	Signal
TP_I	Regulator pin input voltage
TP_EN	EN (enable input signal)
TP_V _{OUT}	V _{OUT} (output voltage)
TP_GND	GND

Schematic and layout

3 Schematic and layout

3.1 Schematic

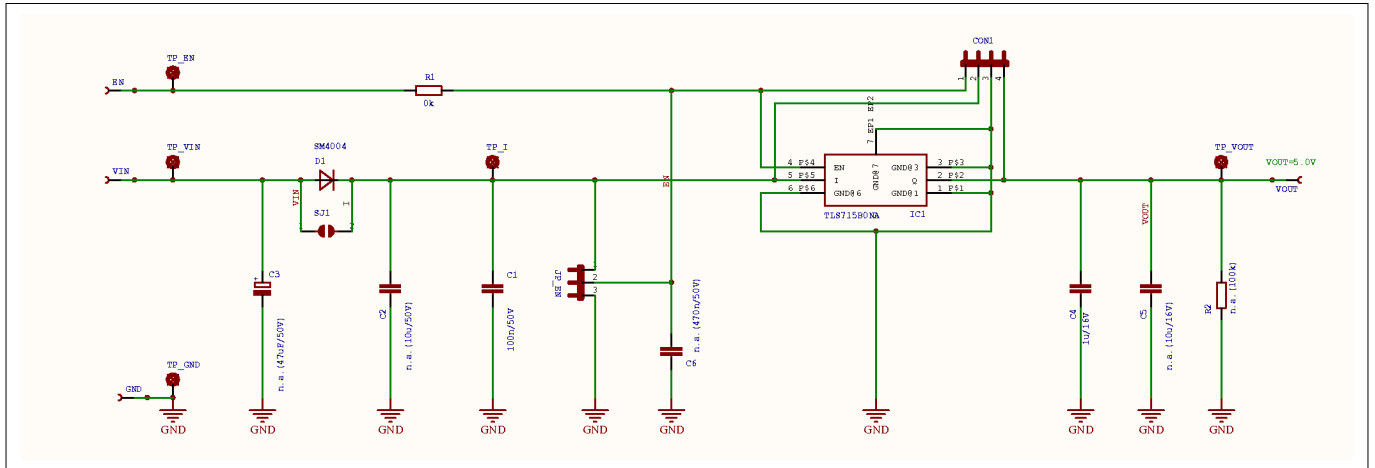

Figure 5 Schematic TLS715B0NAV50 demoboard

Schematic and layout

3.2 Layout

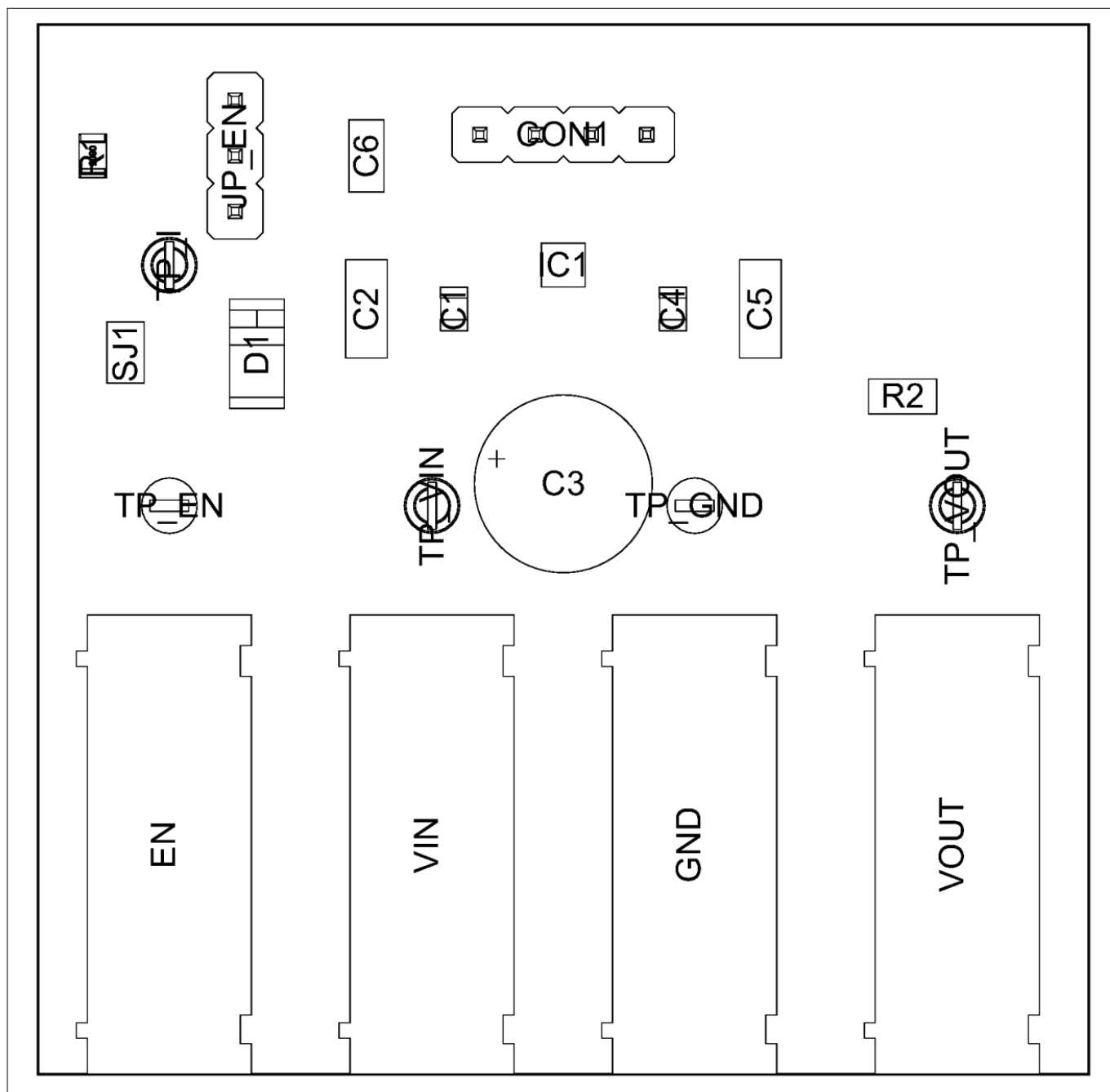

Figure 6 Top layer components TLS715B0NAV50 demoboard

Schematic and layout

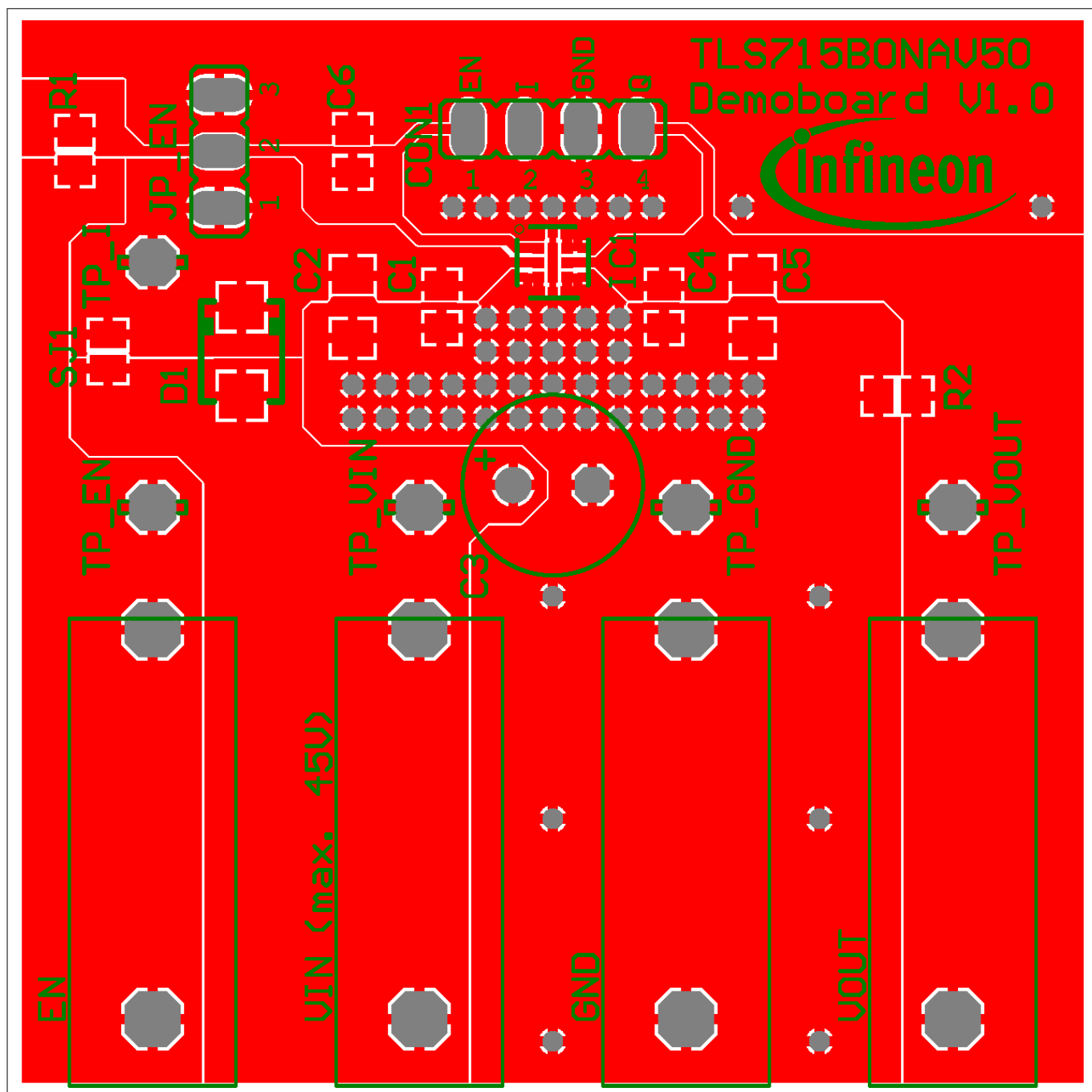

Figure 7 Top layer TLS715B0NAV50 demoboard

Schematic and layout

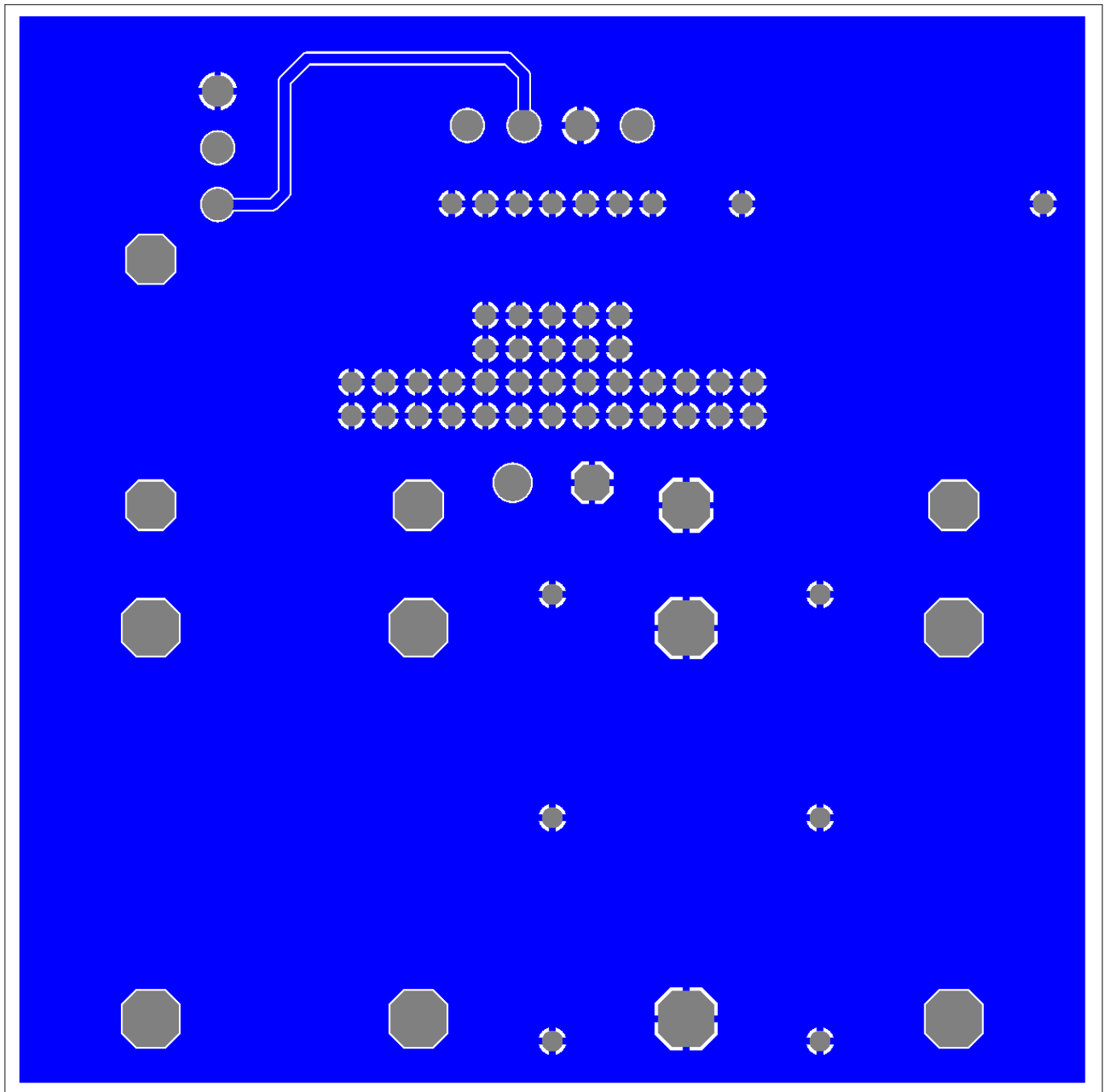

Figure 8 Bottom layer TLS715B0NAV50 demoboard

Bill of material

4 Bill of material

Table 4 Bill of material TLS715B0NAV50 demoboard

Part	Value	Package
VIN, VOUT, GND, EN	Banana jack	BABU4MM
C1	100 nF/50 V	C0805
C2	n.p. (10 μF/50 V)	C1206
C3	n.p. (47 μF/50 V)	E5-8,5
C4	1 μF/16 V	C0805
C5	n.p. (10 μF/16 V)	C1206
C6	n.p. (470 nF/50 V)	C0805
CON1, JP_EN	–	4/3 – pin header 2.54 mm pitch
D1	SM4004	SMA
R1	0 Ω	R0805
R2	n.p. (100 kΩ)	R0805
TP_EN	LSP13	LSP13
TP_GND	LSP13	LSP13
TP_I	LSP13	LSP13
TP_VIN	LSP13	LSP13
TP_VOUT	LSP13	LSP13
SJ1	–	SJ
D1	SM4004	diode
IC1	TLS715B0NAV50	PG-TSNP-7

Restrictions

5 Restrictions

This demoboard offers limited features only for evaluation and testing of Infineon products. The demoboard is not an end product or finished appliance, nor is it intended or authorized by Infineon to be integrated into end products. The demoboard may not be used in any production system.

For further information please visit www.infineon.com.

Revision history

Revision history

Revision	Date	Changes
1.01	2020-02-20	Document updated: editorial changes.
1.0	2017-06-28	Document created.

Trademarks

All referenced product or service names and trademarks are the property of their respective owners.

Edition 2020-02-20

Published by

Infineon Technologies AG

81726 Munich, Germany

© 2020 Infineon Technologies AG

All Rights Reserved.

Do you have a question about any aspect of this document?

Email: erratum@infineon.com

Document reference

IFX-Z8F57824784

IMPORTANT NOTICE

The information contained in this application note is given as a hint for the implementation of the product only and shall in no event be regarded as a description or warranty of a certain functionality, condition or quality of the product. Before implementation of the product, the recipient of this application note must verify any function and other technical information given herein in the real application. Infineon Technologies hereby disclaims any and all warranties and liabilities of any kind (including without limitation warranties of non-infringement of intellectual property rights of any third party) with respect to any and all information given in this application note.

The data contained in this document is exclusively intended for technically trained staff. It is the responsibility of customer's technical departments to evaluate the suitability of the product for the intended application and the completeness of the product information given in this document with respect to such application.

WARNINGS

Due to technical requirements products may contain dangerous substances. For information on the types in question please contact your nearest Infineon Technologies office.

Except as otherwise explicitly approved by Infineon Technologies in a written document signed by authorized representatives of Infineon Technologies, Infineon Technologies' products may not be used in any applications where a failure of the product or any consequences of the use thereof can reasonably be expected to result in personal injury