



TLVH431N family

Adjustable precision shunt regulators

Rev. 2 — 9 December 2020

Product data sheet

1. General description

Three-terminal shunt regulator family with an output voltage range between $V_{ref} = 1.24\text{ V}$ and 14 V, to be set by two external resistors.

Table 1. Product overview

Reference voltage tolerance (V_{ref})	Package	Temperature range (T_{amb})			Pinning configuration (see Table 5)
		0 °C to 70 °C	-40 °C to 85 °C	-40 °C to 125 °C	
1.5 %	SOT23	TLVH431NCDBZR	TLVH431NIDBZR	TLVH431NQDBZR	normal pinning
				TLVH431NMQDBZR	mirrored pinning
1.0 %		TLVH431NACDBZR	TLVH431NAIDBZR	TLVH431NAQDBZR	normal pinning
				TLVH431NAMQDBZR	mirrored pinning

2. Features and benefits

- Programmable output voltage up to 14 V
- Two different reference voltage tolerances:
 - Standard grade: 1.5 %
 - A-Grade: 1 %
- Low output noise
- Typical output impedance: 0.1 Ω
- Sink current capability: 0.08 mA to 70 mA
- AEC-Q100 qualified (grade 1)

3. Applications

- Shunt regulator
- Precision current limiter
- Precision constant current sink
- Isolated feedback loop for Switch Mode Power Supply (SMPS)

4. Quick reference data

Table 2. Quick reference data

Symbol	Parameter	Conditions	Min	Typ	Max	Unit
V_{KA}	cathode-anode voltage		V_{ref}	-	14	V
I_K	cathode current		0.08	-	70	mA
V_{ref}	reference voltage	$V_{KA} = V_{ref}$; $I_K = 10$ mA; $T_{amb} = 25$ °C				
	• Standard-Grade (1.5 %)		1222	1240	1258	mV
	• A-Grade (1.0 %)		1228	1240	1252	mV

5. Pinning information

Table 3. Pinning

Pin	Symbol	Description	Simplified outline	Graphic symbol
SOT23; normal pinning: All types without MQDBZR ending				
1	REF	reference		
2	K	cathode		
3	A	anode		
SOT23; mirrored pinning: All types with MQDBZR ending				
1	K	cathode		
2	REF	reference		
3	A	anode		

6. Ordering information

Table 4. Ordering information

Type number	Package		Version
	Name	Description	
TLVH431NCDBZR	TO-236AB	plastic surface-mounted package; 3 leads	SOT23
TLVH431NIDBZR			
TLVH431NQDBZR			
TLVH431NMQDBZR			
TLVH431NACDBZR			
TLVH431NAIDBZR			
TLVH431NAQDBZR			
TLVH431NAMQDBZR			

7. Marking

Table 5. Marking codes

Type number	Marking code [1]	Type number	Marking code [1]
TLVH431NCDBZR	8M%	TLVH431NACDBZR	8R%
TLVH431NIDBZR	8N%	TLVH431NAIDBZR	8S%
TLVH431NQDBZR	8P%	TLVH431NAQDBZR	8T%
TLVH431NMQDBZR	8Q%	TLVH431NAMQDBZR	8U%

[1] % = placeholder for manufacturing site code.

8. Functional diagram

The TLVH431N family comprises a range of 3-terminal adjustable shunt regulators, with specified thermal stability over applicable automotive and commercial temperature ranges. The output voltage can be set to any value between V_{ref} (approximately 1.24 V) and 14 V with two external resistors (see Figure 10). These devices have a typical output impedance of 0.1 Ω . Active output circuitry provides a very sharp turn-on characteristic, making these devices excellent replacements for Zener diodes in many applications like on-board regulation, adjustable power supplies and switching power supplies.

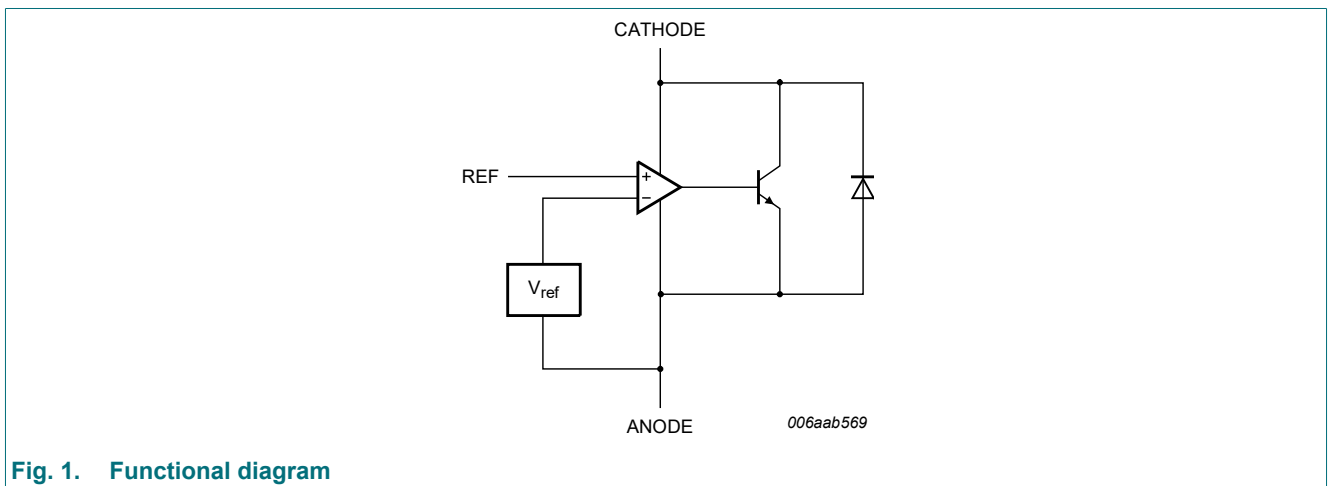

Fig. 1. Functional diagram

9. Limiting values

Table 6. Limiting values

In accordance with the Absolute Maximum Rating System (IEC 60134).

Symbol	Parameter	Conditions	Min	Max	Unit	
V_{KA}	cathode-anode voltage		-	14	V	
I_K	cathode current		-25	80	mA	
I_{ref}	reference current		-	3	mA	
P_{tot}	total power dissipation	$T_{amb} \leq 25\text{ °C}$	[1]	-	350	mW
			[2]	-	580	mW
			[3]	-	950	mW
T_j	junction temperature		-	150	°C	
T_{amb}	ambient temperature					
	TLVH431NXCDBZR		0	+70	°C	
	TLVH431NXIDBZR		-40	+85	°C	
	TLVH431NXQDBZR		-40	+125	°C	
T_{stg}	storage temperature		-65	+150	°C	

- [1] Device mounted on an FR4 Printed-Circuit Board (PCB), single-sided copper, tin-plated and standard footprint.
- [2] Device mounted on an FR4 PCB, single-sided copper, tin-plated, mounting pad for anode 1 cm².
- [3] Device mounted on a ceramic PCB, Al₂O₃, standard footprint.

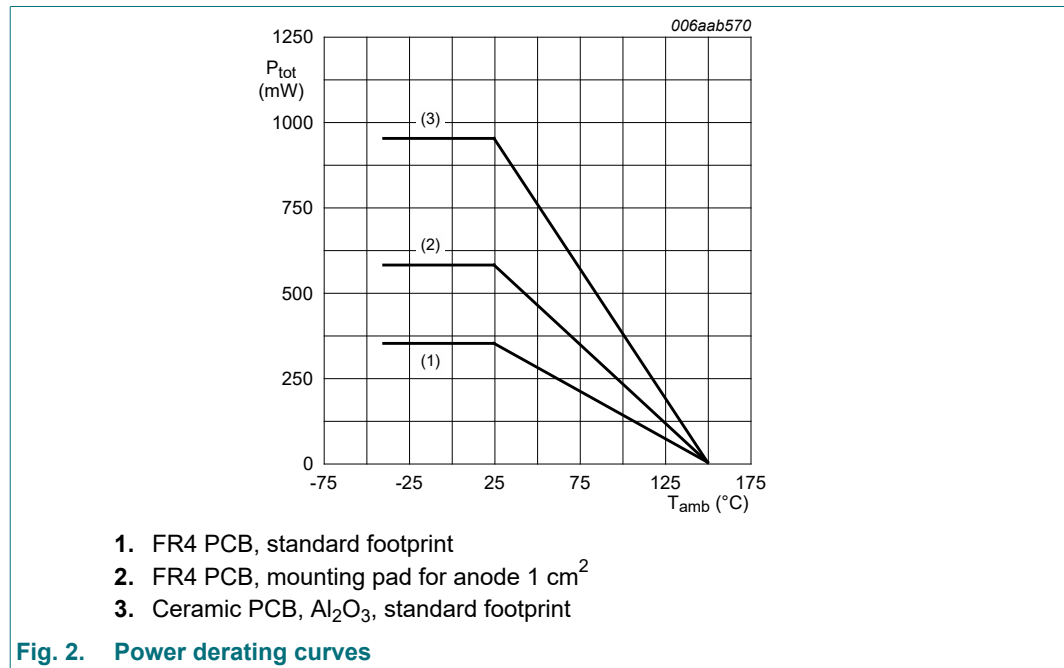

Fig. 2. Power derating curves

Table 7. ESD maximum ratings

$T_{amb} = 25\text{ °C}$ unless otherwise specified.

Symbol	Parameter	Conditions	Min	Max	Unit
V_{ESD}	electrostatic discharge voltage	MIL-STD-883 (human body model)	-	4	kV
		machine model	-	200	V

10. Recommended operating conditions

Table 8. Operating conditions

Symbol	Parameter	Conditions	Min	Max	Unit
V_{KA}	cathode-anode voltage		V_{ref}	14	V
I_K	cathode current		0.08	70	mA

11. Thermal characteristics

Table 9. Thermal characteristics

Symbol	Parameter	Conditions		Min	Typ	Max	Unit
$R_{th(j-a)}$	thermal resistance from junction to ambient	in free air	[1]	-	-	360	K/W
			[2]	-	-	216	K/W
			[3]	-	-	132	K/W
$R_{th(j-sp)}$	thermal resistance from junction to solder point		[4]	-	-	50	K/W

- [1] Device mounted on an FR4 PCB, single-sided copper, tin-plated and standard footprint.
 [2] Device mounted on an FR4 PCB, single-sided copper, tin-plated, mounting pad for anode 1 cm².
 [3] Device mounted on a ceramic PCB, Al₂O₃, standard footprint.
 [4] Soldering point of anode.

12. Characteristics

Table 10. Characteristics
 $T_{amb} = 25\text{ °C}$ unless otherwise specified.

Symbol	Parameter	Conditions	Min	Typ	Max	Unit
Standard-Grade (1.5 %): TLVH431NCDBZR; TLVH431NIDBZR; TLVH431NQDBZR; TLVH431NMQDBZR						
V_{ref}	reference voltage	$V_{KA} = V_{ref}$; $I_K = 10\text{ mA}$; $T_{amb} = 25\text{ °C}$	1222	1240	1258	mV
ΔV_{ref}	reference voltage variation	$V_{KA} = V_{ref}$; $I_K = 10\text{ mA}$				
	TLVH431NCDBZR	$T_{amb} = 0\text{ °C to }70\text{ °C}$	-	2	10	mV
	TLVH431NIDBZR	$T_{amb} = -40\text{ °C to }85\text{ °C}$	-	3	10	mV
	TLVH431NQDBZR	$T_{amb} = -40\text{ °C to }125\text{ °C}$	-	5	10	mV
	TLVH431NMQDBZR					
$\Delta V_{ref}/\Delta V_{KA}$	reference voltage variation to cathode-anode voltage variation ratio	$I_K = 10\text{ mA}$; $\Delta V_{KA} = V_{ref}$ to 14 V	-	-0.8	-2.7	mV/V
I_{ref}	reference current	$I_K = 10\text{ mA}$; $R1 = 10\text{ k}\Omega$; $R2 = \text{open}$	-	0.19	0.30	μA
ΔI_{ref}	reference current variation	$I_K = 10\text{ mA}$; $R1 = 10\text{ k}\Omega$; $R2 = \text{open}$				
	TLVH431NCDBZR	$T_{amb} = 0\text{ °C to }70\text{ °C}$	-	0.03	1.0	μA
	TLVH431NIDBZR	$T_{amb} = -40\text{ °C to }85\text{ °C}$	-	0.06	0.16	μA
	TLVH431NQDBZR	$T_{amb} = -40\text{ °C to }125\text{ °C}$	-	0.07	0.24	μA
	TLVH431NMQDBZR					
$I_{K(min)}$	minimum cathode current	$V_{KA} = V_{ref}$	-	55	80	μA
I_{off}	off-state current	$V_{KA} = 14\text{ V}$; $V_{ref} = 0$	-	0.01	0.05	μA
Z_{KA}	dynamic cathode-anode impedance	$I_K = 0.1\text{ mA to }70\text{ mA}$; $V_{KA} = V_{ref}$; $f < 1\text{ kHz}$	-	0.10	0.15	Ω
A-Grade (1 %): TLVH431NACDBZR; TLVH431NAIDBZR; TLVH431NAQDBZR; TLVH431NAMQDBZR						
V_{ref}	reference voltage	$V_{KA} = V_{ref}$; $I_K = 10\text{ mA}$; $T_{amb} = 25\text{ °C}$	1228	1240	1252	mV
ΔV_{ref}	reference voltage variation	$V_{KA} = V_{ref}$; $I_K = 10\text{ mA}$				
	TLVH431NACDBZR	$T_{amb} = 0\text{ °C to }70\text{ °C}$	-	0.3	10	mV
	TLVH431NAIDBZR	$T_{amb} = -40\text{ °C to }85\text{ °C}$	-	1.3	10	mV
	TLVH431NAQDBZR	$T_{amb} = -40\text{ °C to }125\text{ °C}$	-	2.2	10	mV
	TLVH431NAMQDBZR					
$\Delta V_{ref}/\Delta V_{KA}$	reference voltage variation to cathode-anode voltage variation ratio	$I_K = 10\text{ mA}$; $\Delta V_{KA} = V_{ref}$ to 14 V	-	-0.5	-2.7	mV/V
I_{ref}	reference current	$I_K = 10\text{ mA}$; $R1 = 10\text{ k}\Omega$; $R2 = \text{open}$	-	0.19	0.30	μA
ΔI_{ref}	reference current variation	$I_K = 10\text{ mA}$; $R1 = 10\text{ k}\Omega$; $R2 = \text{open}$				
	TLVH431NACDBZR	$T_{amb} = 0\text{ °C to }70\text{ °C}$	-	0.03	0.10	μA
	TLVH431NAIDBZR	$T_{amb} = -40\text{ °C to }85\text{ °C}$	-	0.06	0.16	μA
	TLVH431NAQDBZR	$T_{amb} = -40\text{ °C to }125\text{ °C}$	-	0.07	0.24	μA
	TLVH431NAMQDBZR					
$I_{K(min)}$	minimum cathode current	$V_{KA} = V_{ref}$	-	55	80	μA
I_{off}	off-state current	$V_{KA} = 14\text{ V}$; $V_{ref} = 0$	-	0.01	0.05	μA
Z_{KA}	dynamic cathode-anode impedance	$I_K = 0.1\text{ mA to }70\text{ mA}$; $V_{KA} = V_{ref}$; $f < 1\text{ kHz}$	-	0.10	0.15	Ω

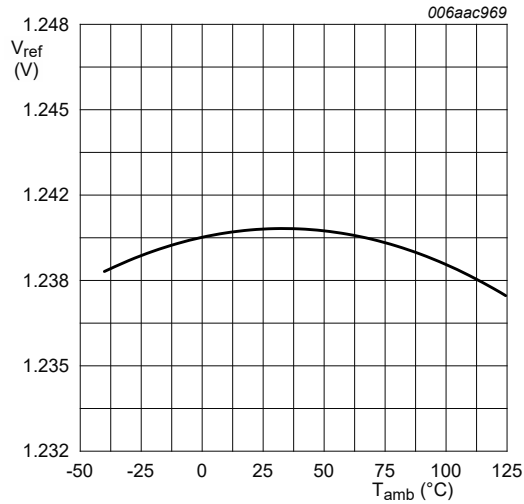

$I_K = 10 \text{ mA}; V_{KA} = V_{ref}$

Fig. 3. Reference voltage as a function of ambient temperature; typical values

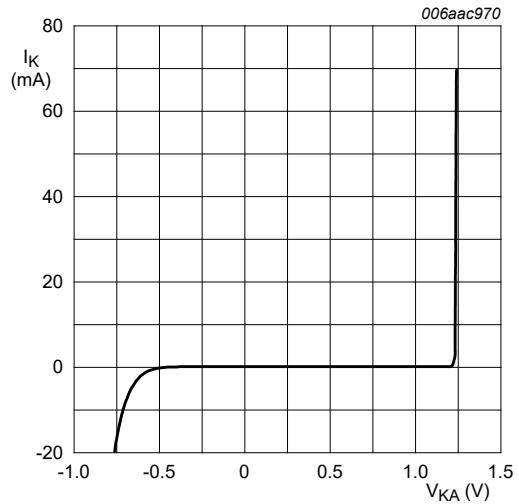

$V_{KA} = V_{ref}; T_{amb} = 25 \text{ °C}$

Fig. 4. Cathode current as a function of cathode-anode voltage; typical values

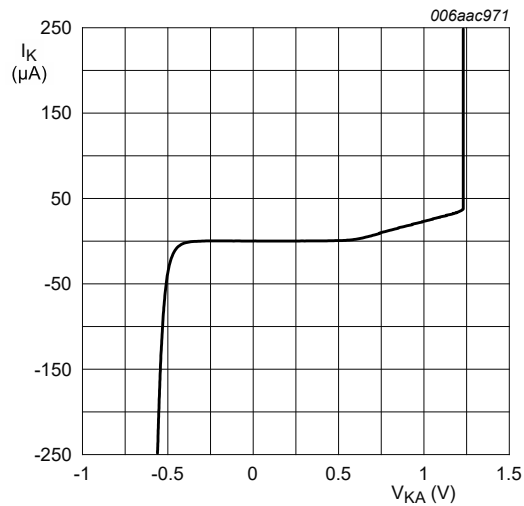

$V_{KA} = V_{ref}; T_{amb} = 25 \text{ °C}$

Fig. 5. Cathode current as a function of cathode-anode voltage; typical values

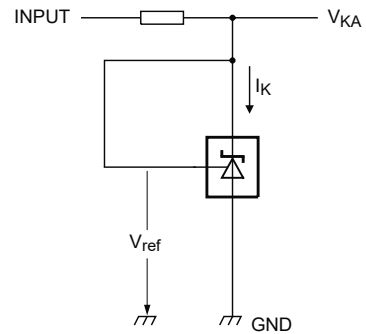

006aac994

$I_K = 10 \text{ mA}; V_{KA} = V_{ref}$

Fig. 6. Test circuit to Figures 3, 4 and 5

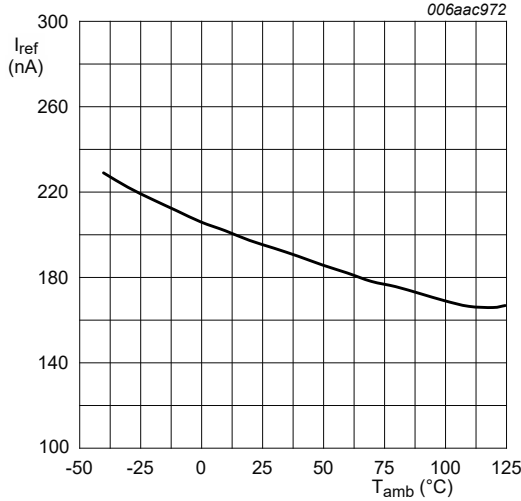

V_{KA} = 1.24 V; I_K = 10 mA; R1 = 10 kΩ; R2 = open

Fig. 7. Reference current as a function of ambient temperature; typical values

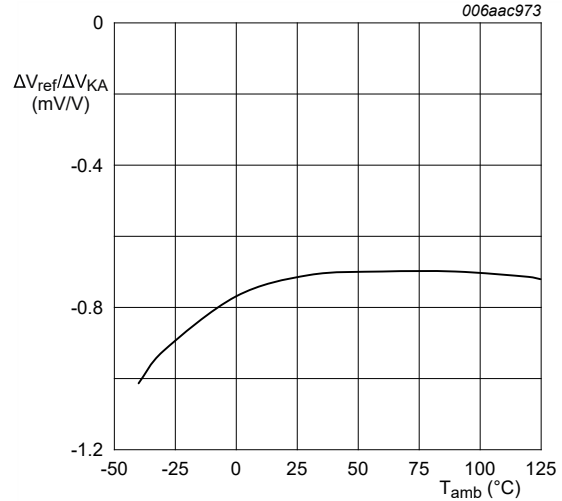

I_K = 10 mA; T_{amb} = 25 °C

Fig. 8. Reference voltage variation to cathode-anode voltage variation ratio as a function of ambient temperature; typical values

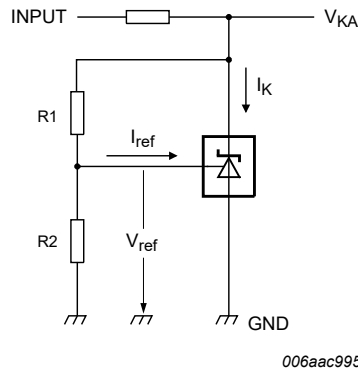

$$V_{KA} = V_{ref} \times (1 + R1/R2) + I_{ref} \times R1$$

Fig. 9. Test circuit to Figures 7 and 8

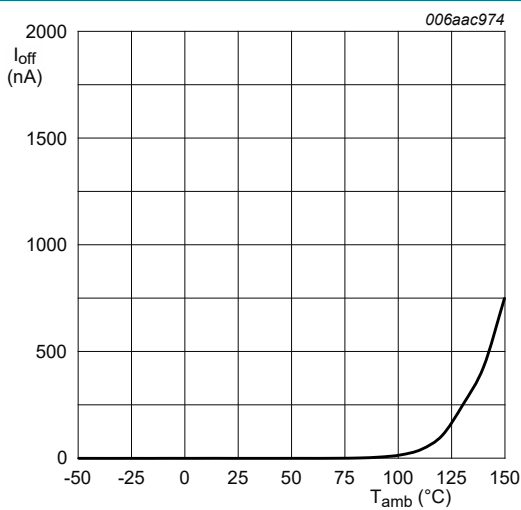

V_{KA} = 14 V; V_{ref} = 0

Fig. 10. Off-state current as a function of ambient temperature; typical values

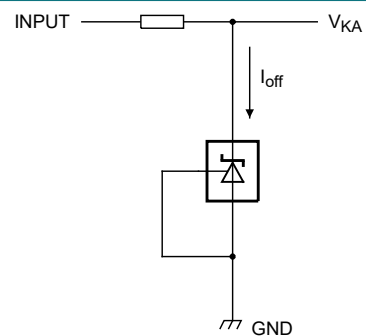

V_{KA} = 14 V; V_{ref} = 0

Fig. 11. Test circuit to Figure 10

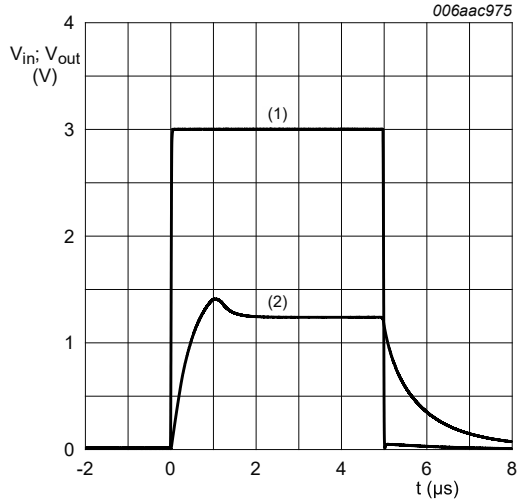

$T_{amb} = 25\text{ }^{\circ}\text{C}$
 (1) Input
 (2) Output

Fig. 12. Input voltage and output voltage as a function of time; typical values

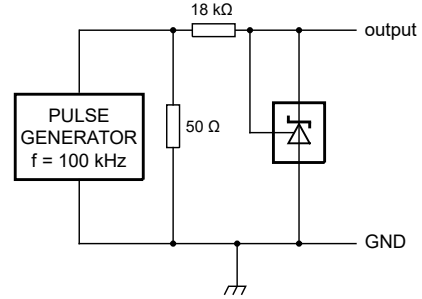

$T_{amb} = 25\text{ }^{\circ}\text{C}$

Fig. 13. Test circuit to Figure 12

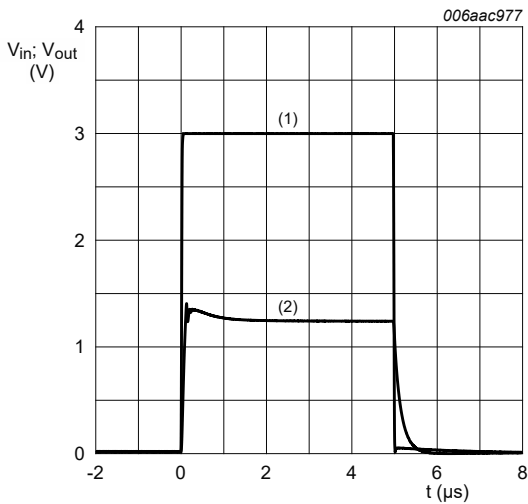

$T_{amb} = 25\text{ }^{\circ}\text{C}$
 (1) Input
 (2) Output

Fig. 14. Input voltage and output voltage as a function of time; typical values

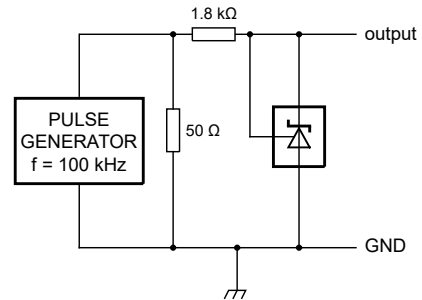

$T_{amb} = 25\text{ }^{\circ}\text{C}$

Fig. 15. Test circuit to Figure 14

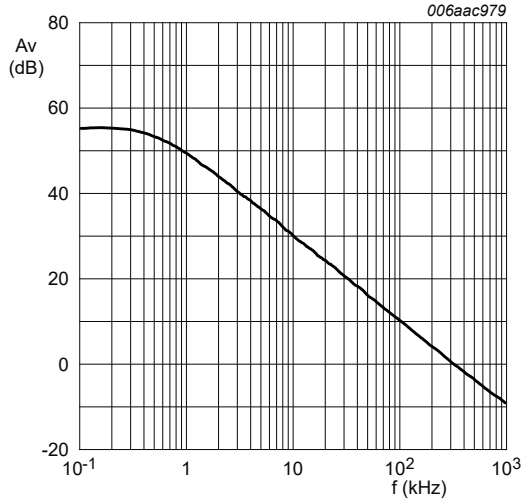

$I_K = 10 \text{ mA}; T_{\text{amb}} = 25 \text{ }^\circ\text{C}$

Fig. 16. Voltage amplification as a function of frequency; typical values

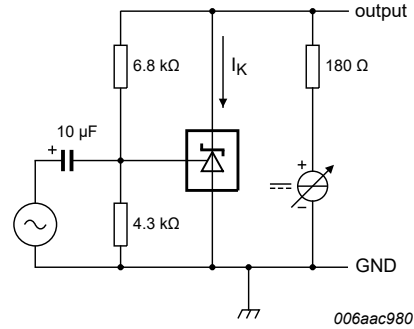

$I_K = 10 \text{ mA}; T_{\text{amb}} = 25 \text{ }^\circ\text{C}$

Fig. 17. Test circuit to Figure 16

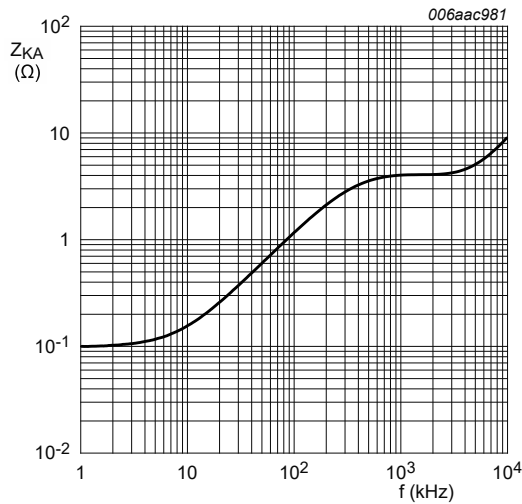

$I_K = 10 \text{ mA}; T_{\text{amb}} = 25 \text{ }^\circ\text{C}$

Fig. 18. Dynamic cathode-anode impedance as a function of frequency; typical values

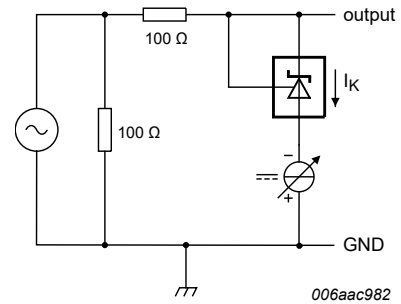

$I_K = 10 \text{ mA}; T_{\text{amb}} = 25 \text{ }^\circ\text{C}$

Fig. 19. Test circuit to Figure 18

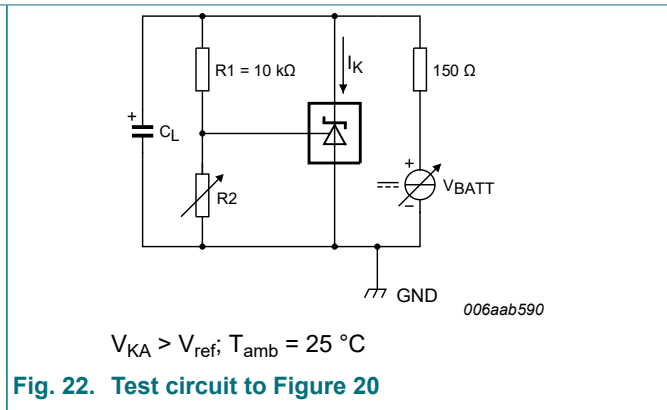
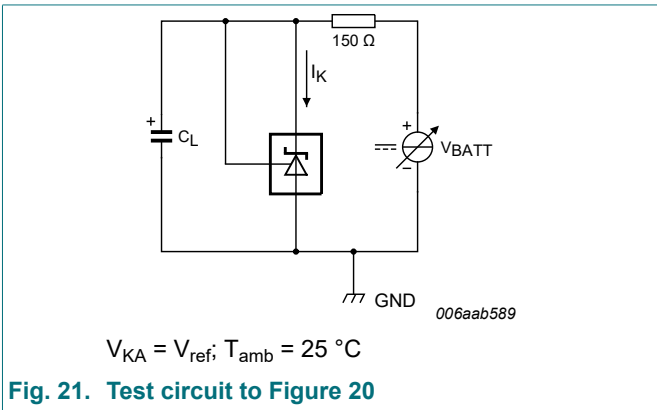
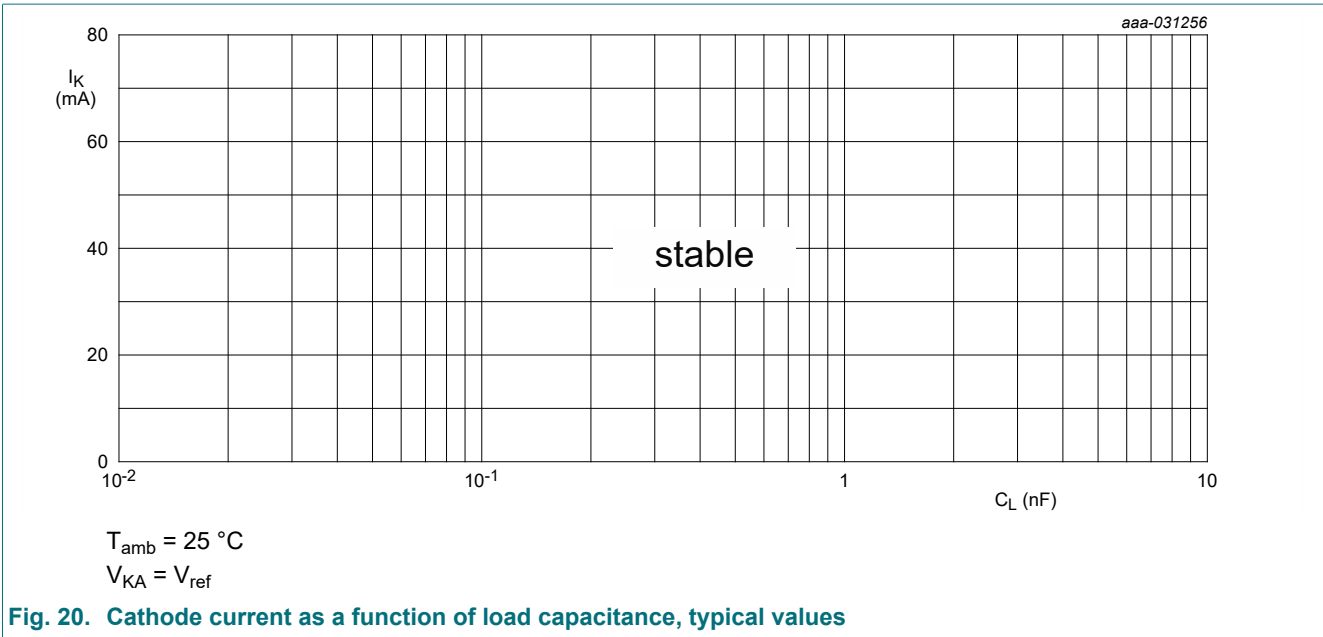

Figures 20, 21 and 22 show the stability boundaries and test circuits for the worst case conditions with a load capacitance mounted as close as possible to the device. The required load capacitance for stable operation varies depending on the operating temperature and capacitor Equivalent Series Resistance (ESR). Verify that the application circuit is stable over the anticipated operating current and temperature ranges.

13. Application information

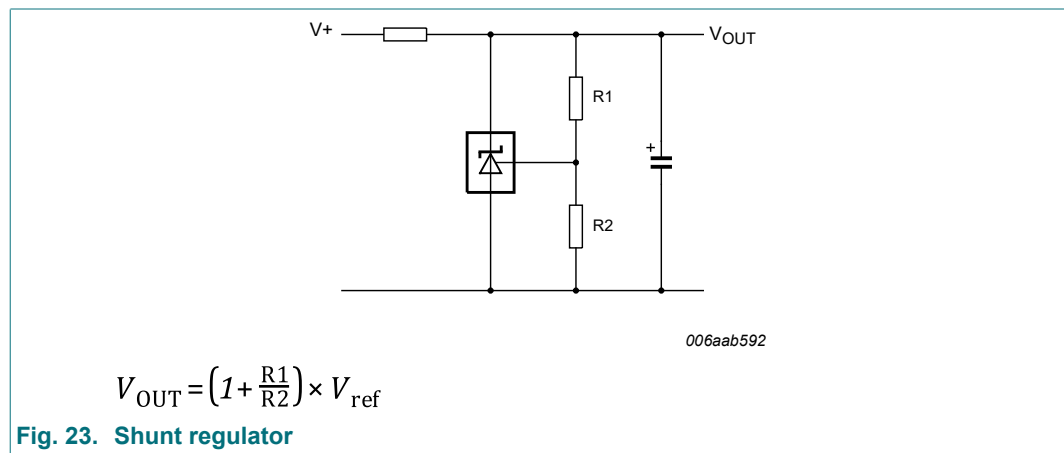

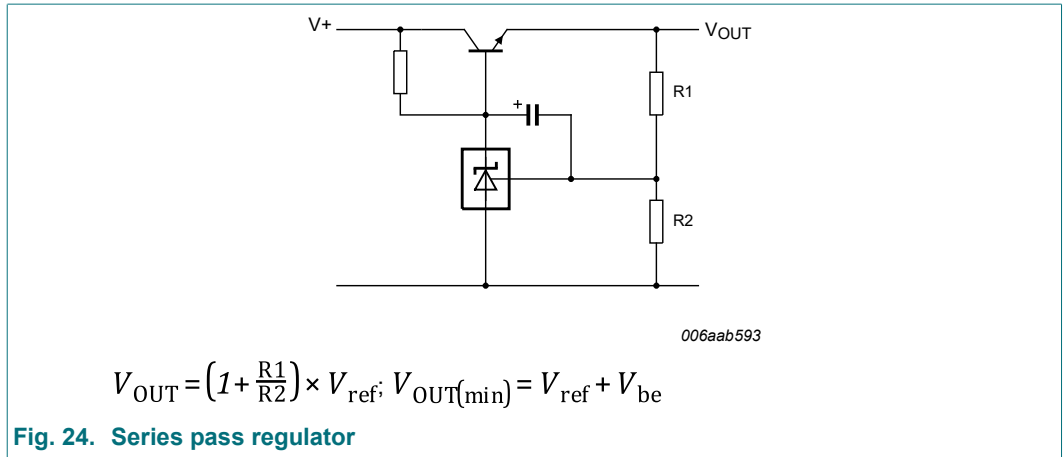

Fig. 24. Series pass regulator

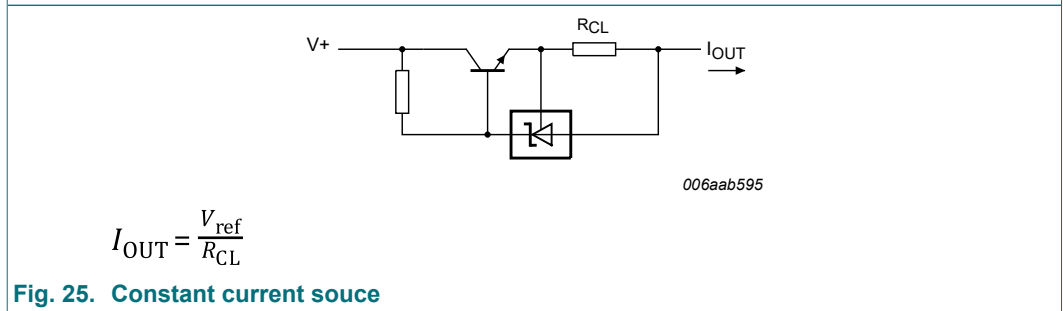

Fig. 25. Constant current source

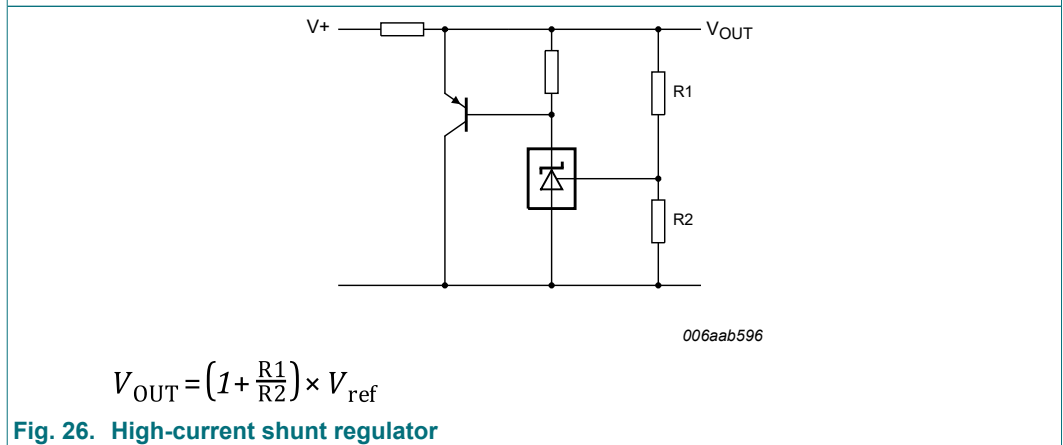

Fig. 26. High-current shunt regulator

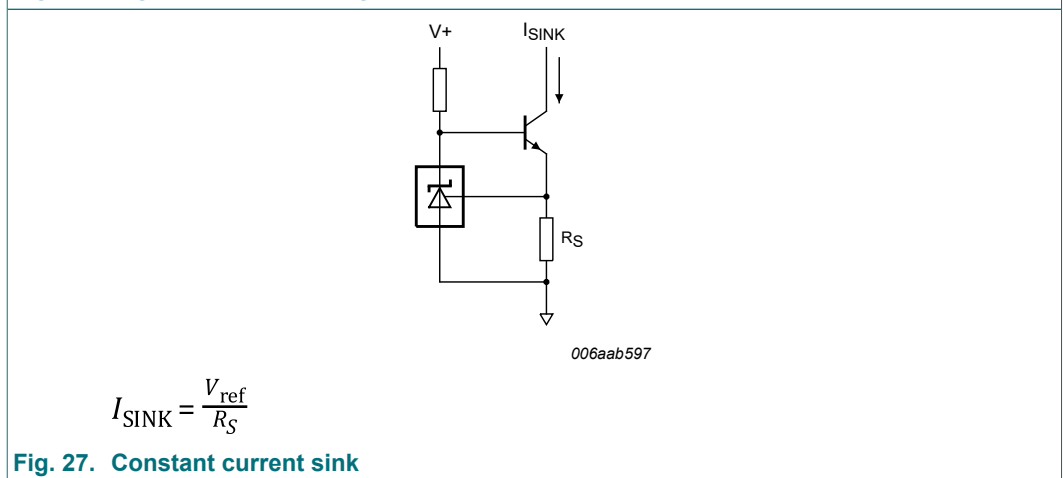

Fig. 27. Constant current sink

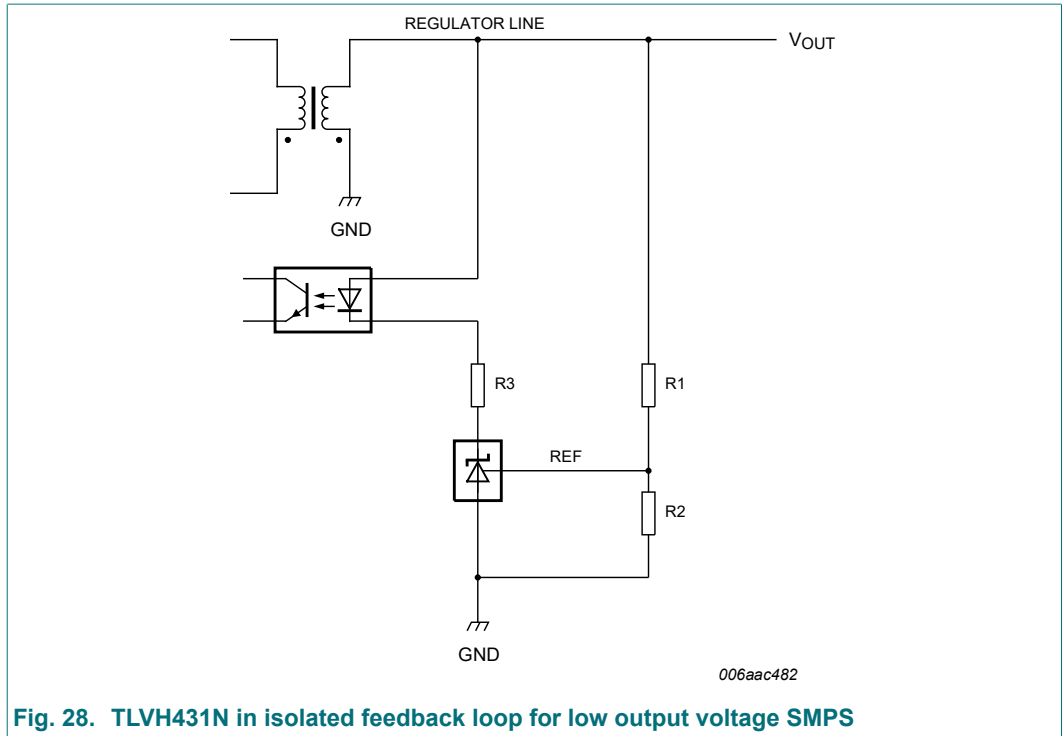

Fig. 28. TLVH431N in isolated feedback loop for low output voltage SMPS

14. Test information

Quality information

This product has been qualified in accordance with the Automotive Electronics Council (AEC) standard Q100 - Failure mechanism based stress test qualification for integrated circuits, and is suitable for use in automotive applications.

15. Package outline

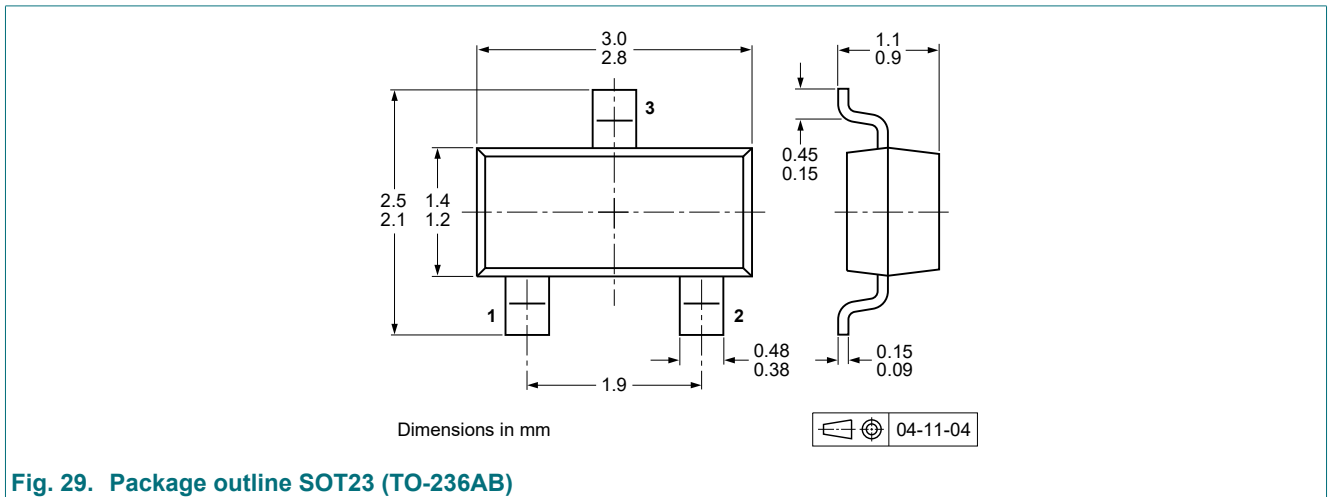

Fig. 29. Package outline SOT23 (TO-236AB)

16. Soldering

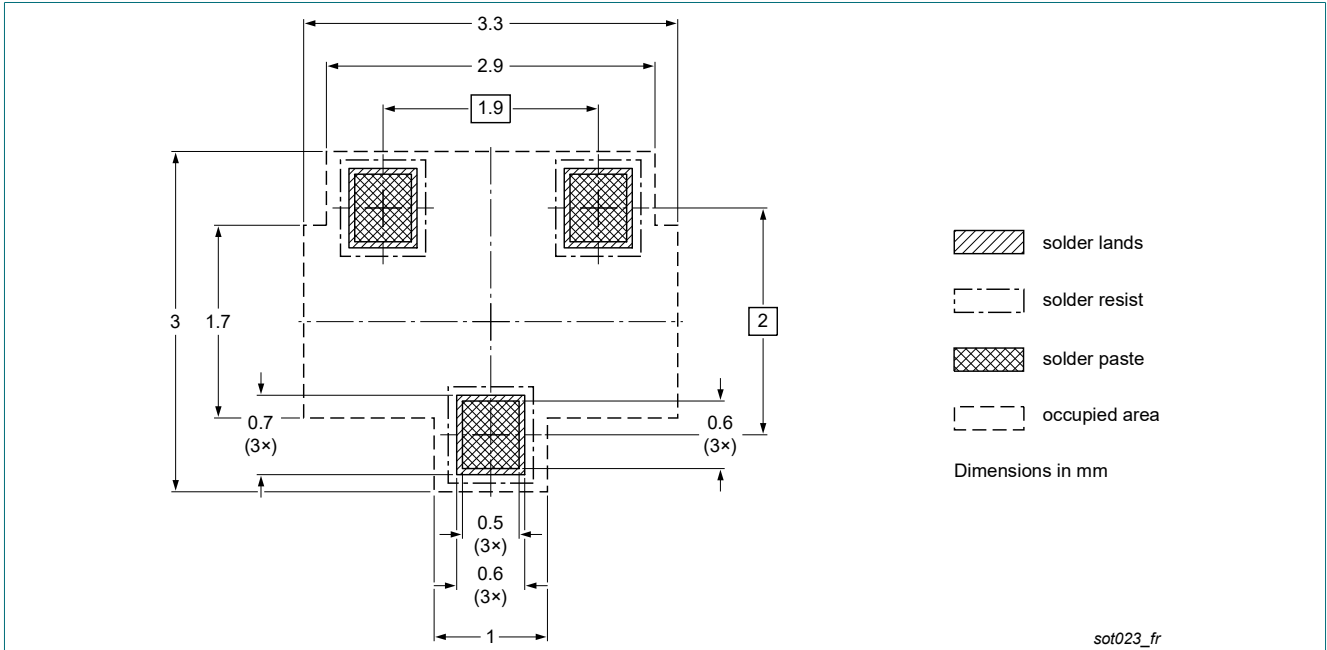

Fig. 30. Reflow soldering footprint SOT23 (TO-236AB)

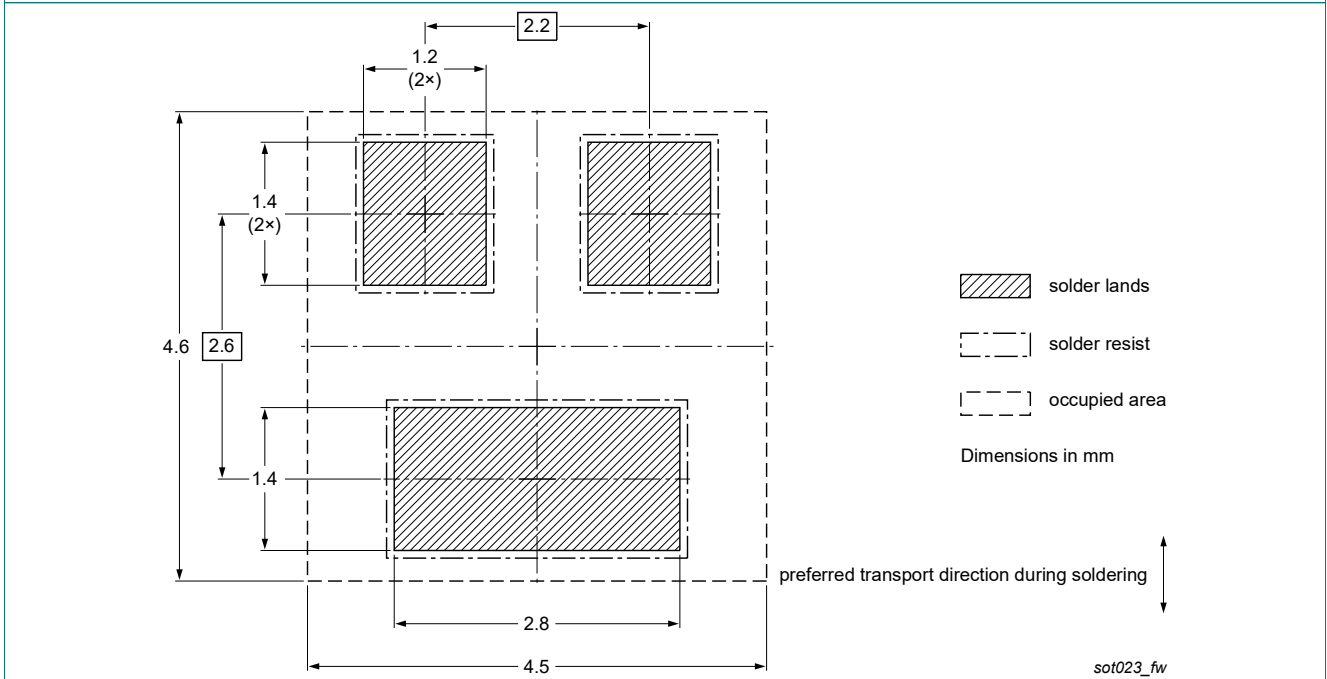

Fig. 31. Wave soldering footprint SOT23 (TO-236AB)

17. Revision history

Table 11. Revision history

Document ID	Release date	Data sheet status	Change notice	Supersedes
TLVH431N_FAM v.2	20201209	Product data sheet	-	-
Modifications:	<ul style="list-style-type: none">• Pinning table changed• Figure 2 changed			
TLVH431N_FAM v.1	20200625	Product data sheet	-	-

18. Legal information

Data sheet status

Document status [1][2]	Product status [3]	Definition
Objective [short] data sheet	Development	This document contains data from the objective specification for product development.
Preliminary [short] data sheet	Qualification	This document contains data from the preliminary specification.
Product [short] data sheet	Production	This document contains the product specification.

- [1] Please consult the most recently issued document before initiating or completing a design.
- [2] The term 'short data sheet' is explained in section "Definitions".
- [3] The product status of device(s) described in this document may have changed since this document was published and may differ in case of multiple devices. The latest product status information is available on the internet at <https://www.nexperia.com>.

Definitions

Draft — The document is a draft version only. The content is still under internal review and subject to formal approval, which may result in modifications or additions. Nexperia does not give any representations or warranties as to the accuracy or completeness of information included herein and shall have no liability for the consequences of use of such information.

Short data sheet — A short data sheet is an extract from a full data sheet with the same product type number(s) and title. A short data sheet is intended for quick reference only and should not be relied upon to contain detailed and full information. For detailed and full information see the relevant full data sheet, which is available on request via the local Nexperia sales office. In case of any inconsistency or conflict with the short data sheet, the full data sheet shall prevail.

Product specification — The information and data provided in a Product data sheet shall define the specification of the product as agreed between Nexperia and its customer, unless Nexperia and customer have explicitly agreed otherwise in writing. In no event however, shall an agreement be valid in which the Nexperia product is deemed to offer functions and qualities beyond those described in the Product data sheet.

Disclaimers

Limited warranty and liability — Information in this document is believed to be accurate and reliable. However, Nexperia does not give any representations or warranties, expressed or implied, as to the accuracy or completeness of such information and shall have no liability for the consequences of use of such information. Nexperia takes no responsibility for the content in this document if provided by an information source outside of Nexperia.

In no event shall Nexperia be liable for any indirect, incidental, punitive, special or consequential damages (including - without limitation - lost profits, lost savings, business interruption, costs related to the removal or replacement of any products or rework charges) whether or not such damages are based on tort (including negligence), warranty, breach of contract or any other legal theory.

Notwithstanding any damages that customer might incur for any reason whatsoever, Nexperia's aggregate and cumulative liability towards customer for the products described herein shall be limited in accordance with the Terms and conditions of commercial sale of Nexperia.

Right to make changes — Nexperia reserves the right to make changes to information published in this document, including without limitation specifications and product descriptions, at any time and without notice. This document supersedes and replaces all information supplied prior to the publication hereof.

Suitability for use in automotive applications — This Nexperia product has been qualified for use in automotive applications. Unless otherwise agreed in writing, the product is not designed, authorized or warranted to be suitable for use in life support, life-critical or safety-critical systems or

equipment, nor in applications where failure or malfunction of an Nexperia product can reasonably be expected to result in personal injury, death or severe property or environmental damage. Nexperia and its suppliers accept no liability for inclusion and/or use of Nexperia products in such equipment or applications and therefore such inclusion and/or use is at the customer's own risk.

Quick reference data — The Quick reference data is an extract of the product data given in the Limiting values and Characteristics sections of this document, and as such is not complete, exhaustive or legally binding.

Applications — Applications that are described herein for any of these products are for illustrative purposes only. Nexperia makes no representation or warranty that such applications will be suitable for the specified use without further testing or modification.

Customers are responsible for the design and operation of their applications and products using Nexperia products, and Nexperia accepts no liability for any assistance with applications or customer product design. It is customer's sole responsibility to determine whether the Nexperia product is suitable and fit for the customer's applications and products planned, as well as for the planned application and use of customer's third party customer(s). Customers should provide appropriate design and operating safeguards to minimize the risks associated with their applications and products.

Nexperia does not accept any liability related to any default, damage, costs or problem which is based on any weakness or default in the customer's applications or products, or the application or use by customer's third party customer(s). Customer is responsible for doing all necessary testing for the customer's applications and products using Nexperia products in order to avoid a default of the applications and the products or of the application or use by customer's third party customer(s). Nexperia does not accept any liability in this respect.

Limiting values — Stress above one or more limiting values (as defined in the Absolute Maximum Ratings System of IEC 60134) will cause permanent damage to the device. Limiting values are stress ratings only and (proper) operation of the device at these or any other conditions above those given in the Recommended operating conditions section (if present) or the Characteristics sections of this document is not warranted. Constant or repeated exposure to limiting values will permanently and irreversibly affect the quality and reliability of the device.

Terms and conditions of commercial sale — Nexperia products are sold subject to the general terms and conditions of commercial sale, as published at <http://www.nexperia.com/profile/terms>, unless otherwise agreed in a valid written individual agreement. In case an individual agreement is concluded only the terms and conditions of the respective agreement shall apply. Nexperia hereby expressly objects to applying the customer's general terms and conditions with regard to the purchase of Nexperia products by customer.

No offer to sell or license — Nothing in this document may be interpreted or construed as an offer to sell products that is open for acceptance or the grant, conveyance or implication of any license under any copyrights, patents or other industrial or intellectual property rights.

Export control — This document as well as the item(s) described herein may be subject to export control regulations. Export might require a prior authorization from competent authorities.

Translations — A non-English (translated) version of a document is for reference only. The English version shall prevail in case of any discrepancy between the translated and English versions.

Trademarks

Notice: All referenced brands, product names, service names and trademarks are the property of their respective owners.