

COPPERHEAD SERIES FIBRE CHANNEL TRANSCEIVER

Line Interface Module



- ⚙ High Performance, low-cost alternative to complete fiber systems.
- ⚙ Compact, small package saves PCB footprint.
- ⚙ Equalizer and transformers isolation provides long distance applications, better transient protection, and common mode rejection.
- ⚙ Low transmit / receive jitter.
- ⚙ Low Power dissipation; 500mW Maximum

Transmitter		Vcc : + 3.13 V to 3.47 V			
Parameter	SYM	MIN	Typical	MAX	UNIT
Power Supply Current (Transmitter + Receiver)	Icc	—	90	110	mA
Input Data Voltage Low	VIL	1.35	—	1.88	V
Input Data Voltage High	VIH	2.07	—	2.58	V
Differential Input Data Voltage	VIN	150	800	1200	mV P-P
Input High Voltage Common Range (Differential)	VIHCMR	2	—	3.3	V
Transmitter Output Impedance (Diff)	Ztx-Diff	100	150	—	Ohms
Output Differential signal level (p-p)	VO	1000	1250	1600	mV
Data Rate (NRZ)	DR	—	266	—	Mb/s
Total P-P transmit jitter	TJ	—	500	900	ps
Output rise-fall time (20%-80%)	TRO	—	—	500	ps

Receiver		Vcc : + 3.13 V to 3.47 V			
Parameter	SYM	MIN	Typical	MAX	UNIT
Input range swing(Differential)	VIN	150	—	1200	mV
Differential Output Data Voltage	VO	423	—	1175	mV P-P
Output Common-Mode Voltage	VOCMR	1.75	1.93	2.05	V
Data Rate (NRZ)	DR	—	266	—	Mb/s
Total P-P transmit jitter	TJ	—	1000	2000	ps

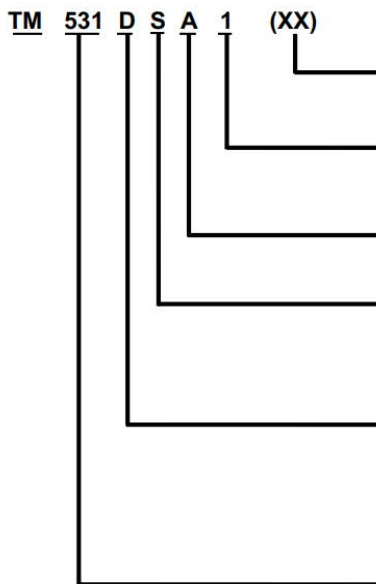

- (XX) - Custom product designator
- blank - No transmit driver
- 1 - 1100 mV output transmit driver and military temperature range
- 2 - 1100 mV output transmit driver and industrial temperature range
- 5 - Active cable equalizer circuit
- A - 5.00 Volt
- B - 3.30 Volt
- S - Impedance matched for STP and twinax (150 ohm)
- U - Impedance matched for unshielded twisted pair (100 ohm)
- V - Impedance matched for video and mini-coax (75 ohm)
- C - Impedance matched for coax (50 ohm)
- D - Gull wing DIP 28-pin package: 0.800"L x 0.400"W x 0.200"H
- F - Gull wing flat pack 28-pin package: 0.760"L x 0.610"W x 0.125"H
- H - Gull wing half DIP 16-pin package: 0.300"L x 0.500"W x 0.250"H
(16-pin package is only available on passive units.)
- 133 - 132.8125 Mbaud version 1/8 speed Fibre Channel/ATM
- 266 - 265.625 Mbaud version 1/4 Speed Fibre Channel
- 531 - 531.25 Mbaud version 1/2 Speed Fibre Channel
- 1062 - 1.0625 Gbaud version Full Speed Fibre Channel
- 1250 - 1.250 Gbaud version, Gigabit Ethernet (both short haul and long haul)
- 1485 - 1.485 Gbaud version, SMPTE

Ordering Information - Part No.



COPPERHEAD SERIES FIBRE CHANNEL TRANSCEIVER

Line Interface Module



Mechanical

Electrical Schematic

SAMPLE SPECS

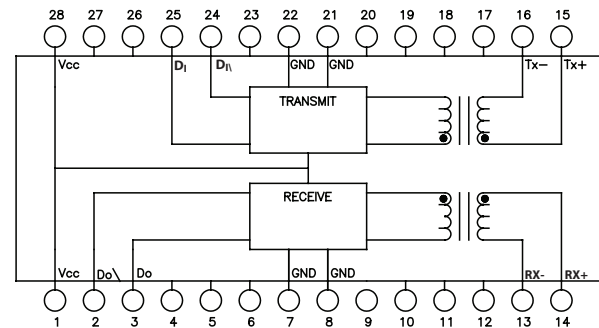
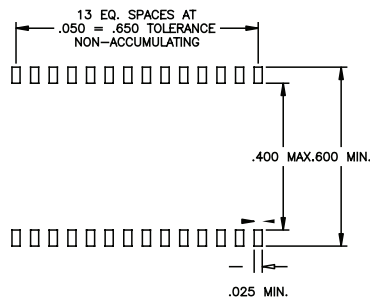
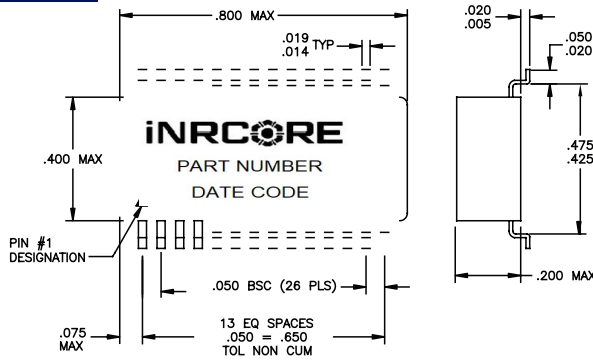

PINS 4,5,6,9,10,11,12,17,18,19,20,23,26 & 27 N/C

Dimensions: $\frac{\text{Inches}}{\text{mm}}$

Unless otherwise specified, all tolerances are: $\pm \frac{.010}{0,25}$

Pin number(s)

- 1, 28 The positive supply for the line interface module. Connect to +3.3V for LVPECL applications.
- 2, 3 D_O, D_O : Differential LVPECL data outputs. These outputs can drive 50 ohm loads connected to V_{CC} - 2.0V. Recommend 150 ohms to Gnd.
- 7, 8 Gnd (V_{EE}): The negative supply for the line interface module. Connect to Gnd for LVPECL applications.
- 13, 14 R_X -, R_X + : Transformer coupled differential inputs to receiver section. For coax applications, R_X - should be connected to shield of cable/earth Gnd; R_X + should be connected to the center conductor. Earth Gnd should be AC coupled to DC signal Gnd using a 0.027 μF capacitor, ~500V.
- 15, 16 T_X +, T_X - : Transformer coupled differential outputs to cable. For coax applications, T_X - should be connected to shield of cable/earth Gnd; T_X + should be connected to the center conductor. Earth Gnd should be AC coupled to DC signal Gnd using a 0.027 μF capacitor, 500V.
- 21, 22 Gnd (V_{EE}): The negative supply for the line interface module. Connect to Gnd for LVPECL applications.
- 24, 25 D_I, D_I : Differential LVPECL compatible data inputs to the transmitter side of the module.
- 4, 5, 6, 9, 10, 11, 12, 17, 18, 19, 20, 23, 26, 27 These pins are "no connect;" do not apply Gnd, VCC, or signal lines to these pins.

