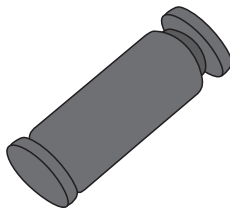


Diac in SMD MINIMELF package


MINIMELF

Features

- V_{BO} : 32 V
- Breakover voltage range : 28 V to 36 V
- ECOPACK compliant

Applications

- Triggering device for Triac or SCR based motor / light dimmer
- 32 V trigger device for oscillator circuit
- Start up triggering in lighting ballast for CFL, TL or LED lamps

Description

Functioning as a trigger diode with a fixed voltage reference, the **TMMDB3** can be used in conjunction with Triacs for simplified gate control circuits or as a starting element in fluorescent lamp ballasts.

Product status link

[TMMDB3](#)

Product summary

Part number	V_{BO}
TMMDB3	28 - 36 V

1 Characteristics

Table 1. Absolute maximum ratings (limiting values), $T_j = 25\text{ }^\circ\text{C}$ unless otherwise specified

Symbol	Parameter	Value	Unit
I_{TRM}	Repetitive peak on-state current, $t_p = 20\ \mu\text{s}$, $F = 120\ \text{Hz}$	2	A
T_{stg}	Storage junction temperature range	-40 to +125	$^\circ\text{C}$
T_j	Operating junction temperature range	-40 to +125	$^\circ\text{C}$

Table 2. Electrical characteristics ($T_j = 25\text{ }^\circ\text{C}$ unless otherwise specified)

Symbol	Parameter	Test conditions	Value	Unit	
V_{BO}	Breakover voltage ⁽¹⁾	$C = 10\ \text{nF}^{(2)}$	Min.	28	V
			Typ.	32	
			Max.	36	
$ V_{BO1} - V_{BO2} $	Breakover voltage symmetry	$C = 10\ \text{nF}^{(2)}$	Max.	3	V
ΔV	Dynamic breakover voltage ⁽¹⁾	V_{BO} and V_F at $10\ \text{mA}$	Min.	5	V
V_O	Output voltage ⁽¹⁾	See Figure 2. Test circuit, ($R = 20\ \Omega$)	Min.	5	V
I_{BO}	Breakover current ⁽¹⁾	$C = 10\ \text{nF}^{(2)}$	Max.	50	μA
t_r	Rise time ⁽¹⁾	See Figure 3. Rise time measurement	Max.	2	μs
I_R	Leakage current ⁽¹⁾	$V_R = 0.5 \times V_{BO}\ \text{max}$	Max.	10	μA
I_P	Peak current ⁽¹⁾	See Figure 2. Test circuit	Min.	0.30	A

1. Applicable to both forward and reverse directions.
2. Connected in parallel to the device

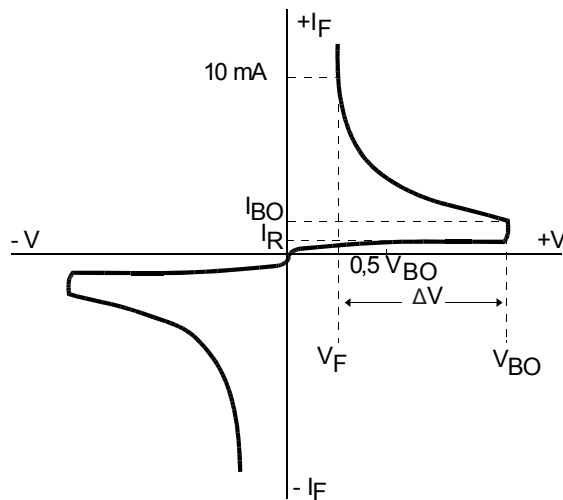
Figure 1. Voltage - current characteristic curve.


Figure 2. Test circuit

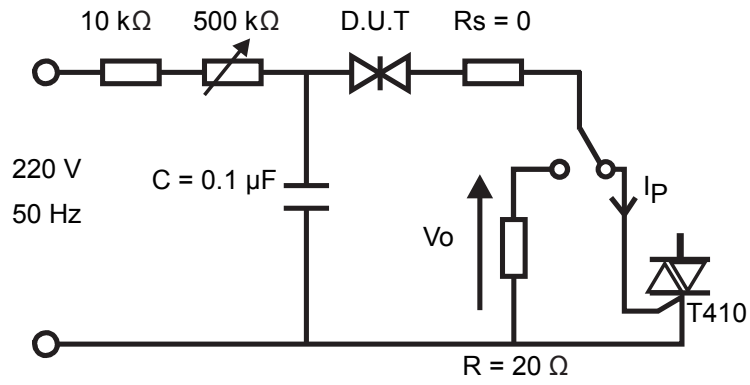
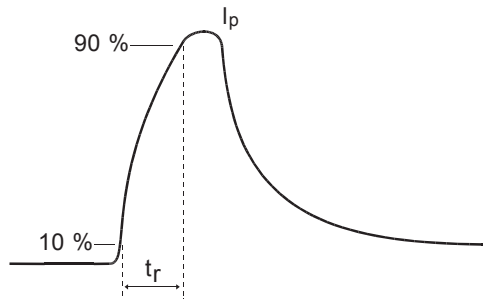


Figure 3. Rise time measurement



1.1 Characteristics curves

Figure 4. Relative variation of VBO versus junction temperature (typical values)

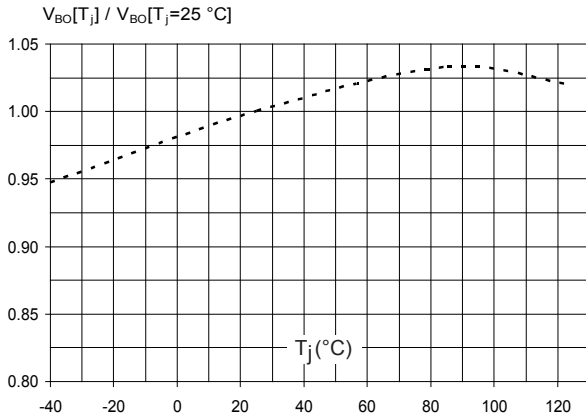


Figure 5. Peak on-state current versus Triac gate current pulse duration t_p

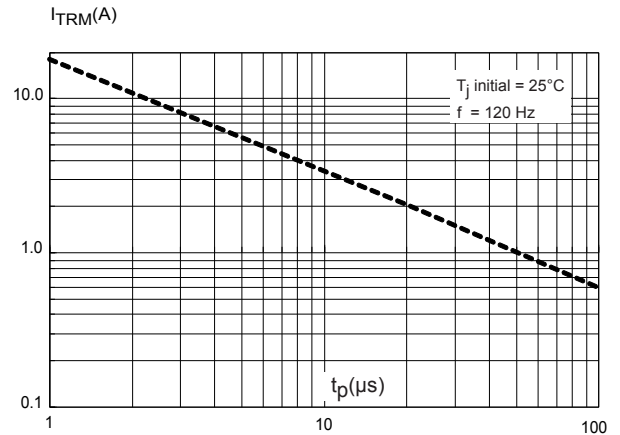
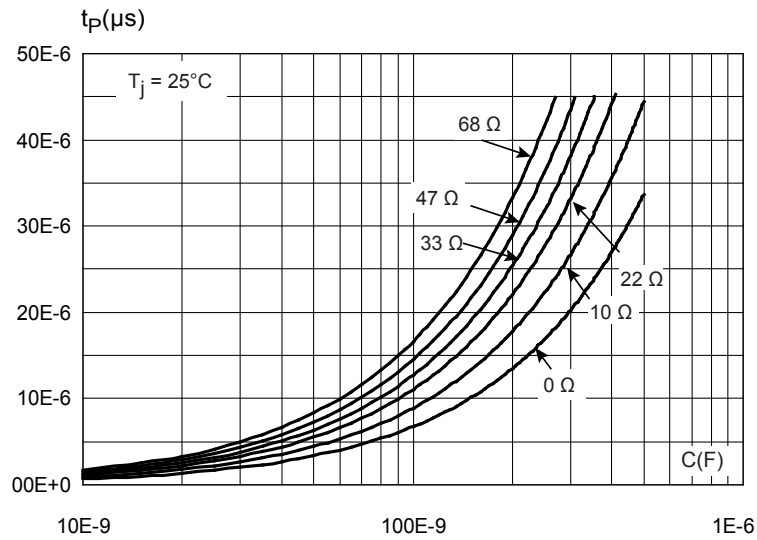


Figure 6. Triac gate current pulse duration t_p (to have $I_p > 50\text{ mA}$) versus R_s and C values (typical values)



Note: according to Figure 2. Test circuit.

2 Package information

In order to meet environmental requirements, ST offers these devices in different grades of **ECOPACK** packages, depending on their level of environmental compliance. ECOPACK specifications, grade definitions and product status are available at: www.st.com. ECOPACK is an ST trademark.

2.1 MINIMELF package information

Figure 7. MINIMELF package outline

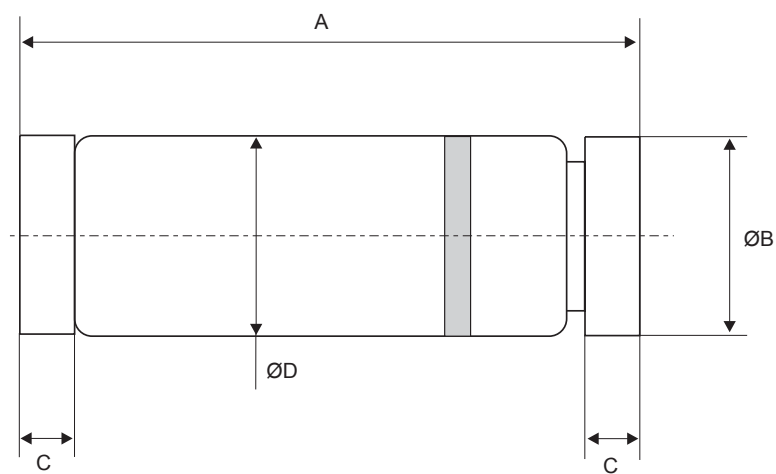
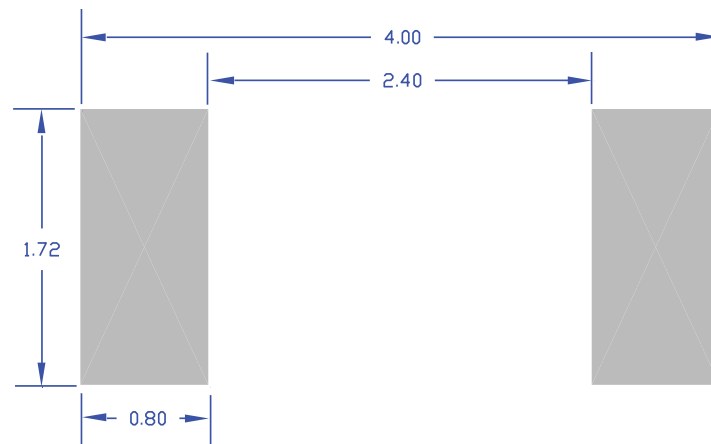


Table 3. MINIMELF package mechanical data

Dim.	mm					
	Min.	Typ.	Max.	Min.	Typ.	Max.
A	3.30	3.50	3.70	0.130	0.138	0.146
B	1.59	1.65	1.70	0.063	0.065	0.067
C	0.40	0.50	0.60	0.016	0.020	0.024
D		1.50			0.059	

Figure 8. MINIMELF recommended footprint (dimensions are in mm)



3 Ordering information

Figure 9. Ordering information scheme

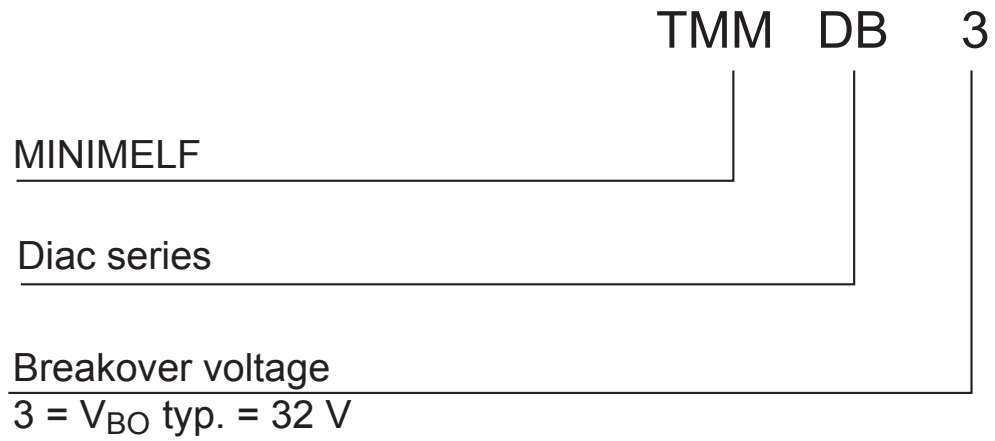


Table 4. Ordering information

Order code	Marking	Package	Weight	Base qty.	Delivery mode
TMMDB3	NA	MINIMELF	0.049 g	2500	Tape and reel

Revision history

Table 5. Document revision history

Date	Version	Changes
29-Jan-2009	3	First release.
07-May-2019	4	Updated Table 3 and Figure 8 . Minor text change to improve readability.