

High temperature 16 A SCRs

Datasheet - production data

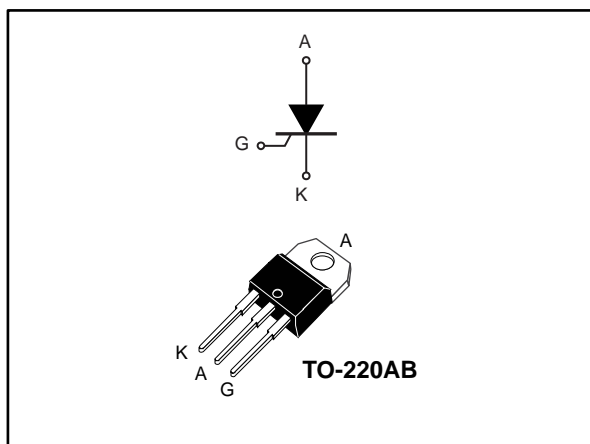

Features

- High junction temperature: $T_j = 150\text{ °C}$
- Gate triggering current $I_{GT} = 6\text{ mA}$
- High noise immunity $dV/dt = 200\text{ V}/\mu\text{s}$ up to 150 °C
- Blocking voltage $V_{DRM}/V_{RRM} = 600\text{ V}$
- High turn-on current rise $dI/dt: 100\text{ A}/\mu\text{s}$
- ECOPACK[®]2 compliant component

Applications

- Motorbikes voltage regulator circuits
- Inrush current limiting circuits
- Motor control circuits and starters
- Light dimmers
- Solid state relays

Description

Designed with high immunity switching to external surges, the device offers robust switching up to its 150 °C maximum T_j .

The combination of noise immunity and low gate triggering current allows to design strong and compact control circuit.

Table 1: Device summary

Order code	Package	V_{DRM}/V_{RRM}	I_{GT}
TN1605H-6T	TO-220AB	600	6 mA

1 Characteristics

Table 2: Absolute maximum ratings (limiting values, $T_j = 25\text{ °C}$ unless otherwise specified)

Symbol	Parameter		Value	Unit
$I_{T(RMS)}$	RMS on-state current (180° conduction angle)		$T_c = 133\text{ °C}$	16 A
$I_{T(AV)}$	Average on-state current (180° conduction angle)		$T_c = 133\text{ °C}$	10
			$T_c = 138\text{ °C}$	8
			$T_c = 142\text{ °C}$	6
I_{TSM}	Non repetitive surge peak on-state current	$t_p = 8.3\text{ ms}$	$T_j\text{ initial} = 25\text{ °C}$	153
		$t_p = 10\text{ ms}$		140
I^2t	I^2t value for fusing	$t_p = 10\text{ ms}$		98 A^2s
di/dt	Critical rate of rise of on-state current	$I_G = 2 \times I_{GT}$, $t_r \leq 100\text{ ns}$,	$f = 60\text{ Hz}$	100 $A/\mu s$
V_{DRM}/V_{RRM}	Repetitive peak off-state voltage		$T_j = 150\text{ °C}$	600 V
V_{DSM}/V_{RSM}	Non repetitive surge peak off-state voltage	$t_p = 10\text{ ms}$		700 V
$P_G(AV)$	Average gate power dissipation		$T_j = 150\text{ °C}$	1 W
V_{RGM}	Maximum peak reverse gate voltage			5 V
I_{GM}	Peak gate current	$t_p = 20\text{ }\mu s$	$T_j = 150\text{ °C}$	4 A
P_{GM}	Peak gate power dissipation	$t_p = 20\text{ }\mu s$	$T_j = 150\text{ °C}$	40 W
$P_G(AV)$	Average gate power dissipation		$T_j = 150\text{ °C}$	1 W
T_{stg}	Storage junction temperature range			-40 to +150 °C
T_j	Operating junction temperature range			-40 to +150 °C
T_L	Maximum lead temperature for soldering during 10 s			260 °C

Table 3: Dynamic characteristics

Symbol	Parameter	T_j		Value	Unit
I_{GT}	$V_D = 12\text{ V}$, $R_L = 33\text{ }\Omega$	25 °C	Min.	3.5	mA
			Typ.	4.5	
			Max.	6	
V_{GT}			Max.	1.3	V
V_{GD}	$V_D = 600\text{ V}$, $R_L = 3.3\text{ k}\Omega$	150 °C	Min.	0.15	V
I_L	$I_G = 1.2 \times I_{GT}$	25 °C	Max.	40	mA
I_H	$I_T = 500\text{ mA}$, gate open		Max.	20	
dV/dt	$V_D = 402\text{ V}$, gate open	150 °C	Min.	200	$V/\mu s$
t_{gt}	$I_{TM} = 32\text{ A}$, $V_D = 402\text{ V}$, $I_G = 12\text{ mA}$, $(dI_G/dt)_{max} = 0.2\text{ A}/\mu s$	25 °C	Typ.	1.9	μs
t_q	$I_{TM} = 32\text{ A}$, $V_D = 402\text{ V}$, $(dI/dt)_{off} = 30\text{ A}/\mu s$, $V_R = 25\text{ V}$, $dV_D/dt = 20\text{ V}/\mu s$	150 °C	Typ.	70	μs

Table 4: Static electrical characteristics

Symbol	Test Conditions	T _j		Value	Unit
V _{TM}	I _{TM} = 32 A, t _p = 380 μs	25 °C	Max.	1.6	V
V _{TO}	Threshold on-state voltage	150 °C	Max.	0.82	V
R _D	Dynamic resistance	150 °C	Max.	25	mΩ
I _{DRM} /I _{RPM}	V _{DRM} = V _{RPM}	25 °C	Max.	5	μA
		125 °C		1.5	mA
		150 °C		3.1	

Table 5: Thermal resistance

Symbol	Parameter	Value	Unit
R _{th(j-c)}	Junction to case (DC)	1.1	°C/W
R _{th(j-a)}	Junction to ambient (DC)	60	

1.1 Characteristics (curves)

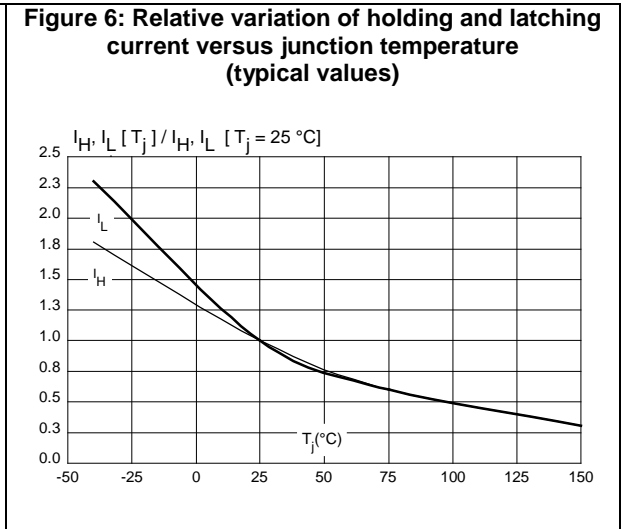
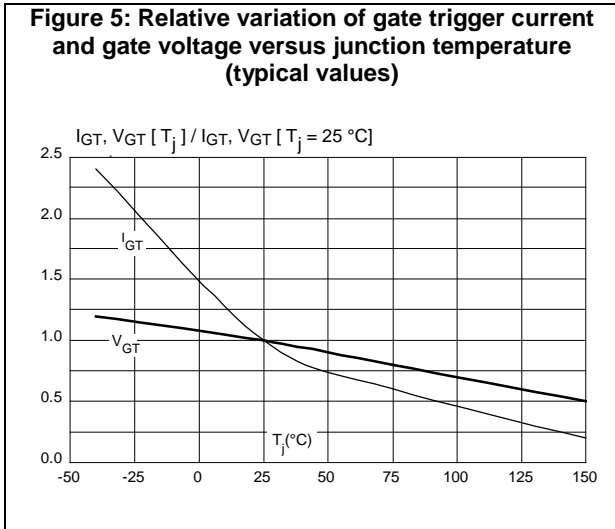
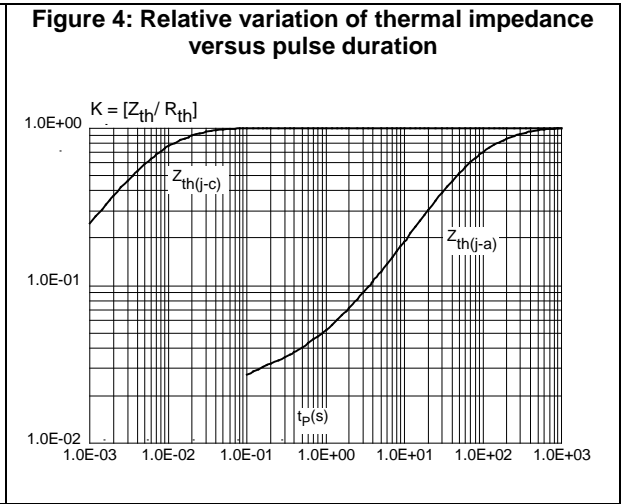
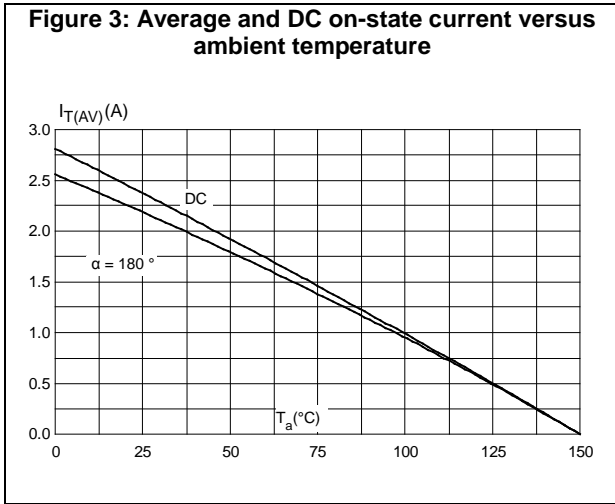
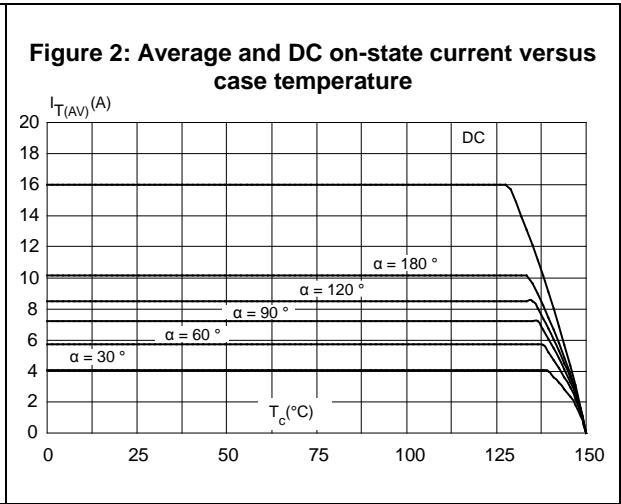
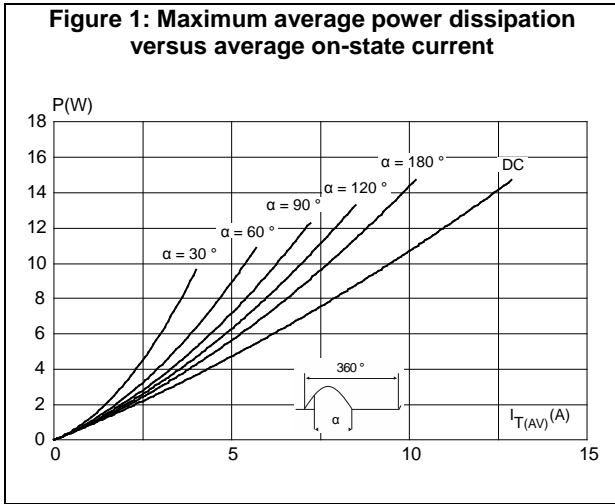

Figure 7: Relative variation of static dV/dt immunity versus junction temperature (typical values)

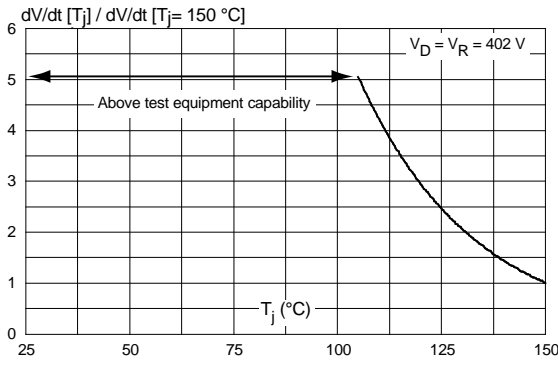

Figure 8: Surge peak on-state current versus number of cycles

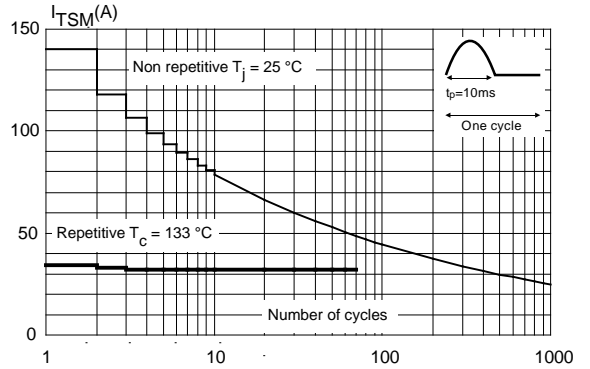

Figure 9: Non repetitive surge peak on-state current versus sinusoidal pulse width (tp < 10 ms).

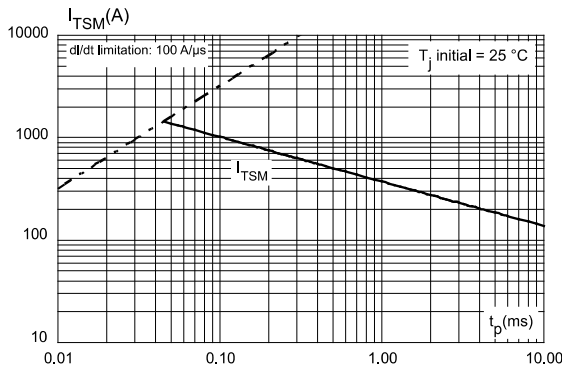

Figure 10: On-state characteristics (maximum values)

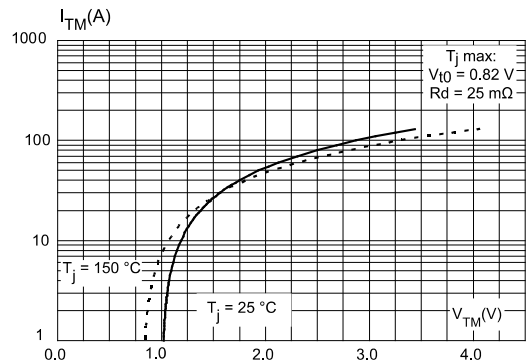
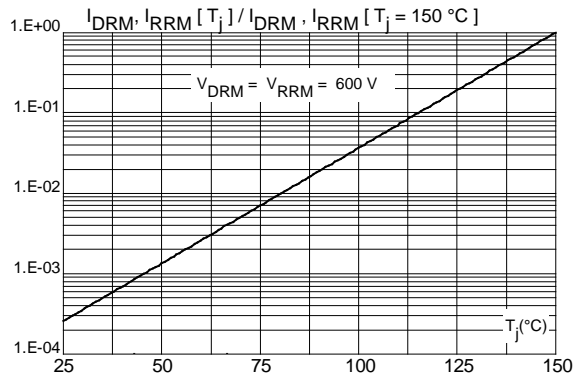

Figure 11: Relative variation of leakage current versus junction temperature (tp < 10ms)



2 Package information

In order to meet environmental requirements, ST offers these devices in different grades of ECOPACK® packages, depending on their level of environmental compliance. ECOPACK® specifications, grade definitions and product status are available at: www.st.com. ECOPACK® is an ST trademark.

- Epoxy meets UL 94,V0
- Lead-free package

2.1 TO-220AB (NIns. and Ins.) package information

Figure 12: TO-220AB (NIns. & Ins.) package outline

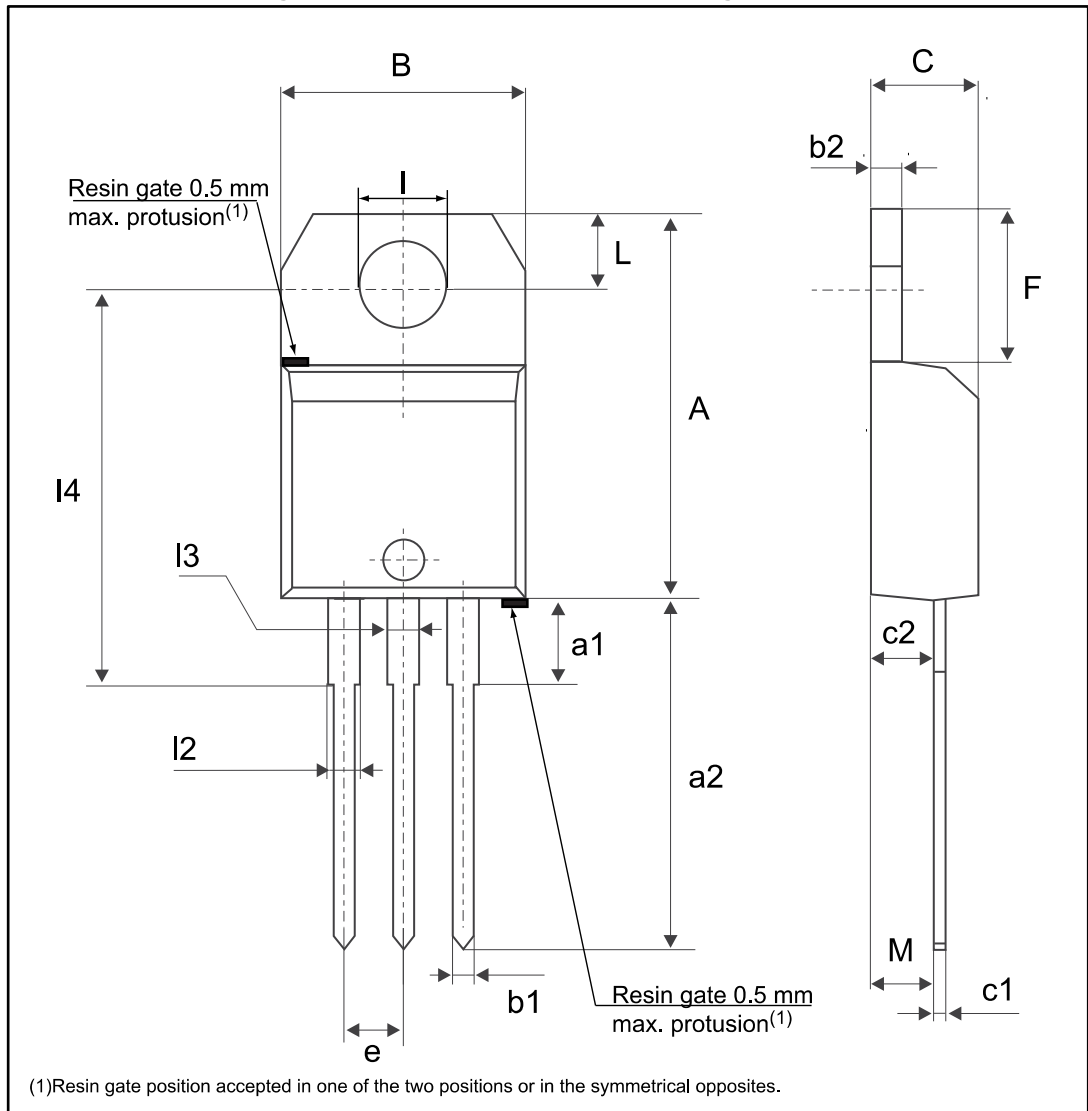

Table 6: TO-220AB (NIns. & Ins.) package mechanical data

Ref.	Dimensions					
	Millimeters			Inches ⁽¹⁾		
	Min.	Typ.	Max.	Min.	Typ.	Max.
A	15.20		15.90	0.5984		0.6260
a1		3.75			0.1476	
a2	13.00		14.00	0.5118		0.5512
B	10.00		10.40	0.3937		0.4094
b1	0.61		0.88	0.0240		0.0346
b2	1.23		1.32	0.0484		0.0520
C	4.40		4.60	0.1732		0.1811
c1	0.49		0.70	0.0193		0.0276
c2	2.40		2.72	0.0945		0.1071
e	2.40		2.70	0.0945		0.1063
F	6.20		6.60	0.2441		0.2598
I	3.73		3.88	0.1469		0.1528
L	2.65		2.95	0.1043		0.1161
I2	1.14		1.70	0.0449		0.0669
I3	1.14		1.70	0.0449		0.0669
I4	15.80	16.40	16.80	0.6220	0.6457	0.6614
M		2.6			0.1024	

Notes:

⁽¹⁾Inch dimensions are for reference only.

3 Ordering information

Figure 13: Ordering information scheme

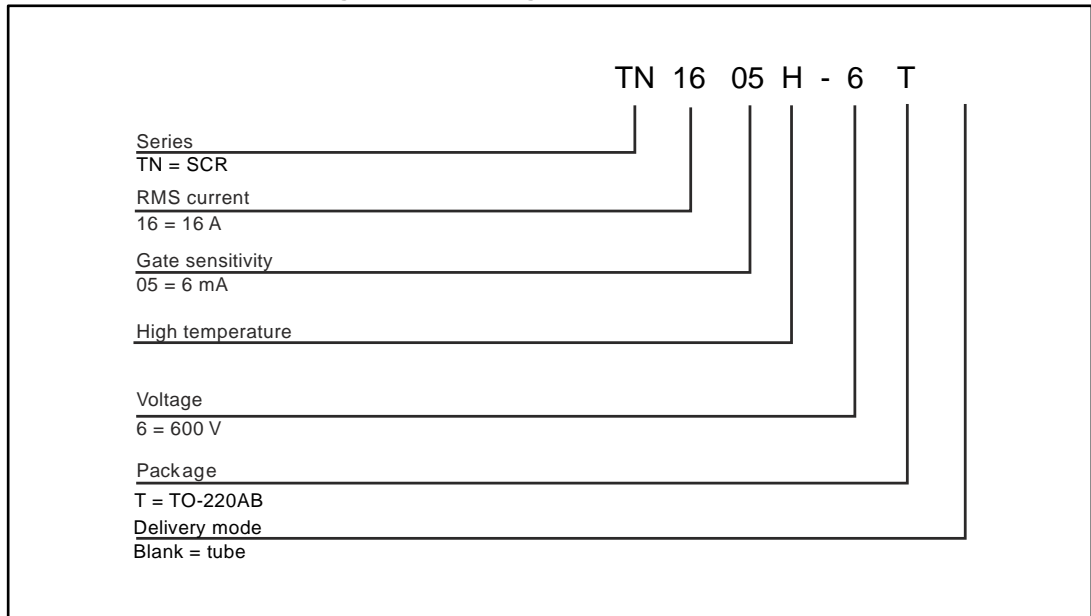

Table 7: Ordering information

Order code	Marking	Package	Weight	Base qty.	Delivery mode
TN1605H-6T	TN1605H6	TO-220AB	2.3 g	50	Tube

4 Revision history

Table 8: Document revision history

Date	Revision	Changes
19-May-2017	1	Initial release.