

DRAWING FOR REFERENCE: This is subject to change without notice
08/11/2012

TO
RF

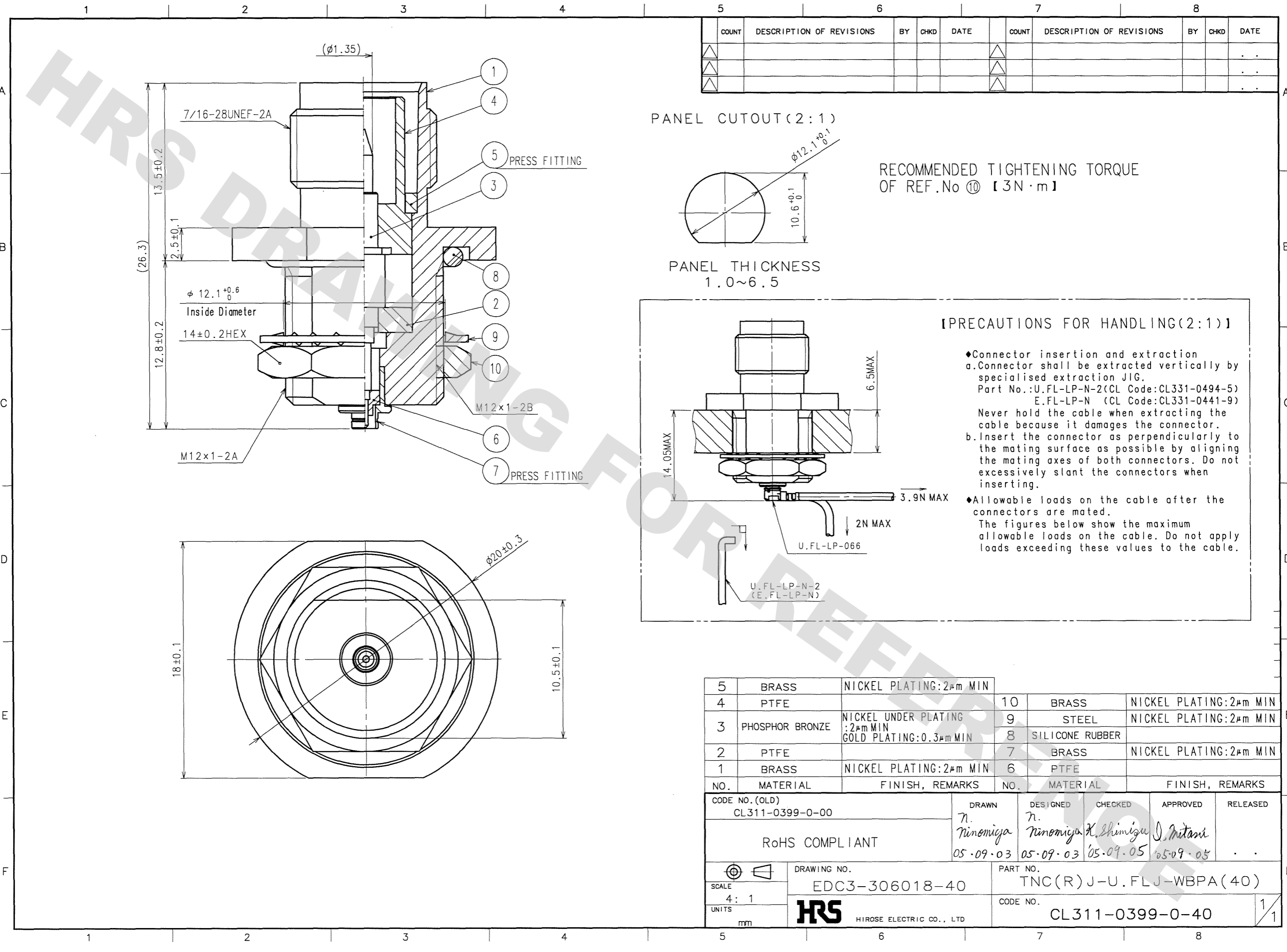

COUNT	DESCRIPTION OF REVISIONS	BY	CHKD	DATE	COUNT	DESCRIPTION OF REVISIONS	BY	CHKD	DATE

PANEL CUTOUT (2:1)

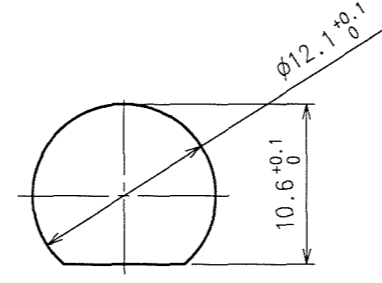

RECOMMENDED TIGHTENING TORQUE
OF REF.No ⑩ 【3N·m】

PANEL THICKNESS
1.0~6.5

【PRECAUTIONS FOR HANDLING (2:1)】

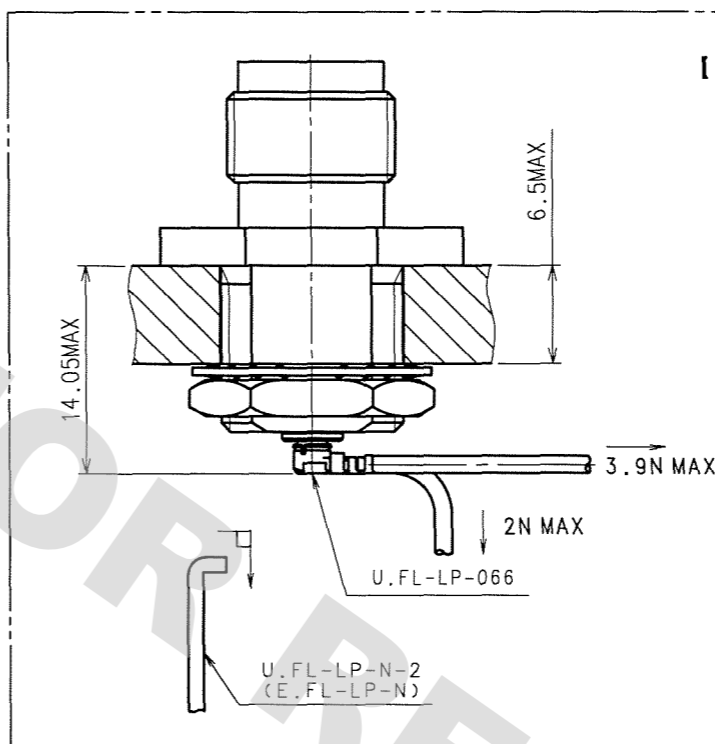

- ◆Connector insertion and extraction
 - a. Connector shall be extracted vertically by specialised extraction JIG.
Part No.: U.FL-LP-N-2 (CL Code: CL331-0494-5)
E.FL-LP-N (CL Code: CL331-0441-9)
 - Never hold the cable when extracting the cable because it damages the connector.
 - b. Insert the connector as perpendicularly to the mating surface as possible by aligning the mating axes of both connectors. Do not excessively slant the connectors when inserting.
- ◆Allowable loads on the cable after the connectors are mated.
The figures below show the maximum allowable loads on the cable. Do not apply loads exceeding these values to the cable.

NO.	MATERIAL	FINISH, REMARKS	NO.	MATERIAL	FINISH, REMARKS
5	BRASS	NICKEL PLATING: 2μm MIN	10	BRASS	NICKEL PLATING: 2μm MIN
4	PTFE		9	STEEL	NICKEL PLATING: 2μm MIN
3	PHOSPHOR BRONZE	NICKEL UNDER PLATING: 2μm MIN GOLD PLATING: 0.3μm MIN	8	SILICONE RUBBER	
2	PTFE		7	BRASS	NICKEL PLATING: 2μm MIN
1	BRASS	NICKEL PLATING: 2μm MIN	6	PTFE	

CODE NO. (OLD) CL311-0399-0-00		DRAWN n. Ninomiya	DESIGNED n. Ninomiya	CHECKED K. Shimizu	APPROVED J. Mitani	RELEASED
RoHS COMPLIANT		05-09-03	05-09-03	05-09-05	05-09-05	
SCALE 4: 1	DRAWING NO. EDC3-306018-40	PART NO. TNC(R)J-U.FLJ-WBPA(40)		CODE NO. CL311-0399-0-40		
UNITS mm	HRS HIROSE ELECTRIC CO., LTD				1/1	