

# RED INDICATES ORIGINAL

DWG SIZE  
D

DATA CONTAINED IN THIS DOCUMENT IS PROPRIETARY TO TROMPETER ELECTRONICS INC. AND SHALL NOT BE DISCLOSED, COPIED OR USED FOR PROCUREMENT OR MANUFACTURE WITHOUT EXPRESS WRITTEN PERMISSION.

REV		ECO	DESCRIPTION	DWN	APPROVED	DATE
0	13428		CHANGE ITEM 4; FROM: 8-1525 TO: 8-1525-1 AND ITEM 7; FROM: 8-2218 TO 8-2218-1; SEE ECO	DKC	<i>[Signature]</i>	6/13/00

305-0590 SH 1C

DASH NO	DESCRIPTION	DASH NO	DESCRIPTION
-1	TERM (NO CHAIN)	-8	TERM WITH 4.0 BRASS CHAIN
-2	TERM WITH 2.5 BRASS CHAIN	-9	TERM WITH 4.0 NYLON CHAIN
-3	TERM WITH 2.5 NYLON CHAIN	-10	TERM WITH 10.0 BRASS CHAIN
-4	TERM WITH 3.0 BRASS CHAIN	-11	TERM WITH 10.0 NYLON CHAIN
-5	TERM WITH 3.0 NYLON CHAIN	-12	TERM WITH 2.5 SST ROPE
-6	TERM WITH 6.0 BRASS CHAIN	-13	TERM WITH 3.0 SST ROPE
-7	TERM WITH 6.0 BRASS CHAIN	-14	TERM WITH 6.0 SST ROPE

MODEL NO	TYPE
TNGBJM1	3-LUG
TNTBJM1	THREADED
TNGBJMFL1	4-LUG

DASH NO	"A" DIA	"B" DIA	"C" DIM
-D2	.630	.750	1.066
-D3	.505	.625	.941
-D4	.439	.562	.878
-D5	.380	.500	.816
-D6	.317	.437	.753
-D7	.281	.406	.722
-D8	.610	.750	1.066
-D9	.567	.687	1.003

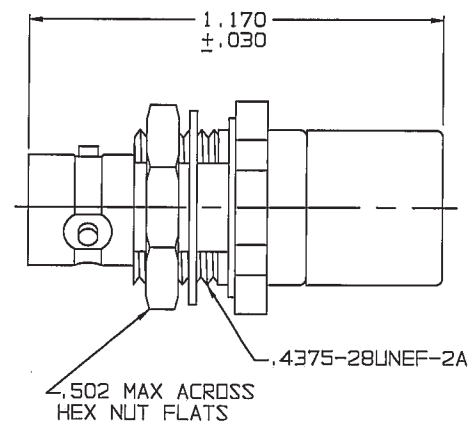

TNGBJM1-1- $\Delta$  SHOWN  
NO CHAIN/ROPE OR MOUNTING LUG

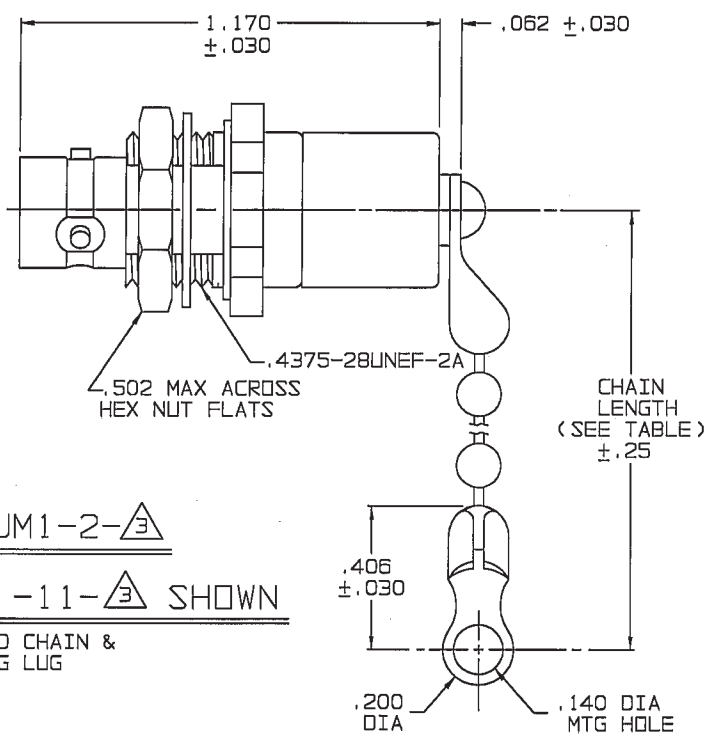

TNGBJM1-2- $\Delta$   
THRU -11- $\Delta$  SHOWN  
STANDARD CHAIN & MOUNTING LUG

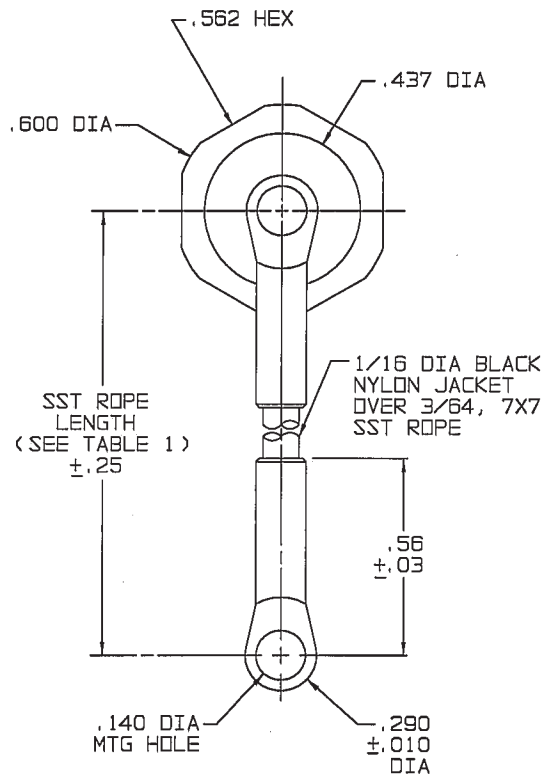

TNGBJM1-12- $\Delta$   
THRU -14- $\Delta$  SHOWN  
STAINLESS STEEL ROPE AND MOUNTING LUG

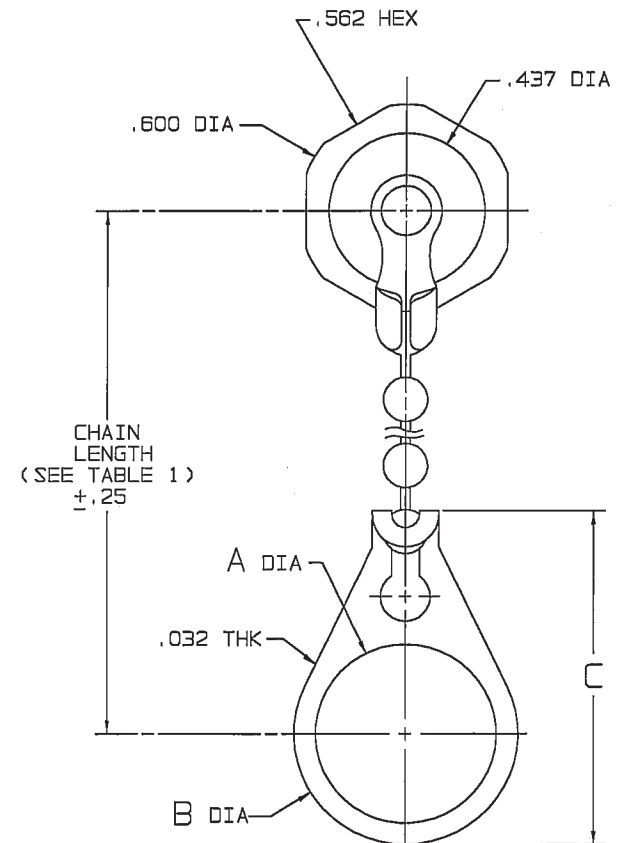

TNGBJM1-2- $\Delta$ -D2  
THRU -11- $\Delta$ -D9 SHOWN  
STANDARD CHAIN AND BULKHEAD JACK MOUNTING LUG

- MAXIMUM PANEL THICKNESS .187
- SOCKET CONTACT TRS SERIES CONCENTRIC TWINAX/TRIAX 3/4 -LUG/THREADED SUBMINIATURE TERMINATED BULKHEAD JACK
- EXAMPLE OF COMPLETE MODEL NO:

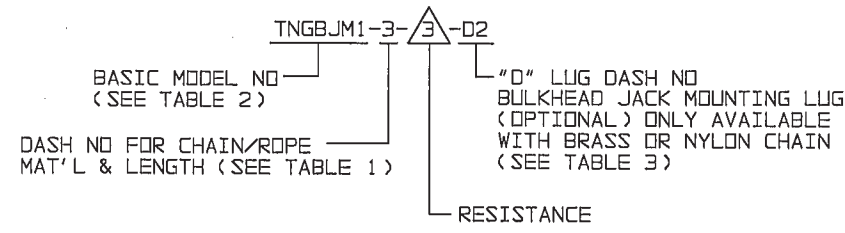

- $\Delta$  RESISTANCE VALUE IN OHMS 1/8, 1%
- FINISH: TFS-1A (NICKEL)
  - ALL DIM ARE IN INCHES

INCH	MM	INCH	MM	INCH	MM	INCH	MM	INCH	MM
.005	0.13	.281	7.14	.505	12.83	.750	19.05	4.0	101.60
.010	0.25	.290	7.37	.56	14.22	.753	19.13	6.0	152.40
.030	0.76	.317	8.05	.562	14.27	.816	20.73	10.0	254.00
.032	0.81	.380	9.65	.567	14.40	.878	22.30		
.062	1.57	.406	10.31	.600	15.24	.941	23.90		
.140	3.56	.437	11.10	.610	15.49	1.003	25.48		
.187	4.75	.439	11.15	.625	15.88	1.066	27.08		
.190	4.83	.443	11.25	.630	16.00	1.170	29.72		
.200	5.08	.500	12.70	.687	17.45	2.5	63.5		
.25	6.35	.502	12.75	.722	18.34	3.0	76.2		

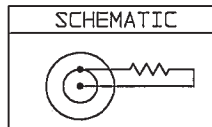
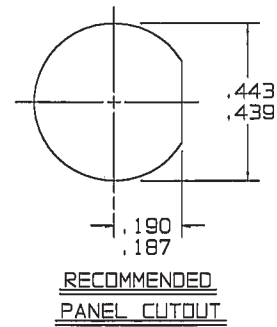

QTY	DESCRIPTION	PART NUMBER	ITEM
TOL UNLESS SPECIFIED XXX ± .005 XXXXX ANGLE	TROMPETER RF CONNECTIVITY	TNGBJM1/TNTBJM1/ TNGBJMFL1	
DWN   EKC   B-5-00	MATERIAL	CODE IDENT	DRAWING NO.
CHK   [Signature]   02-01	14949	305-0590	REV
ENGR   [Signature]	SCALE 4/1	DATE 2-3-86	SHEET 1C
APPR   [Signature]			