

C TP-106

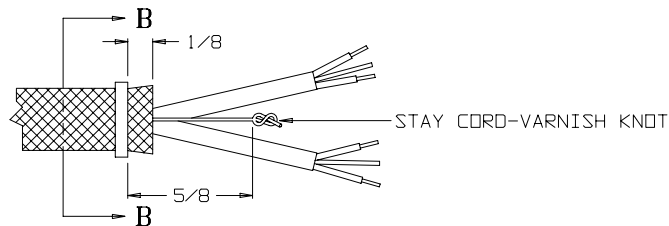
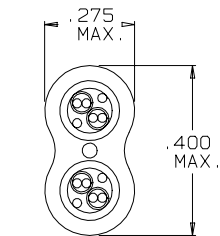
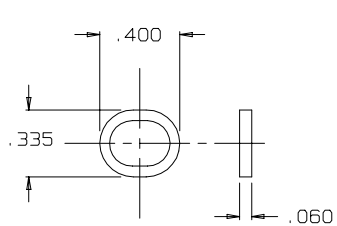
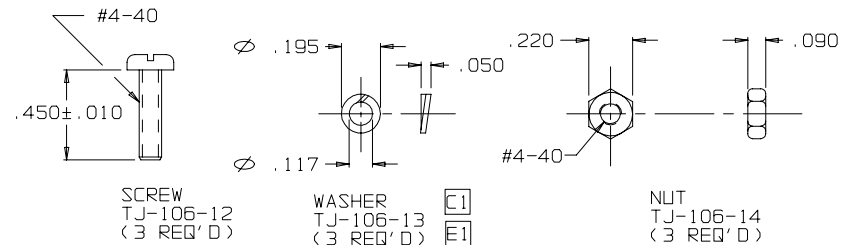
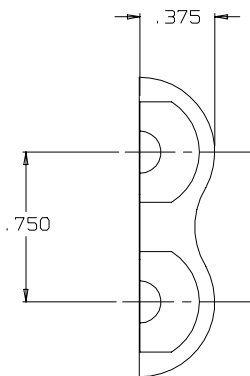
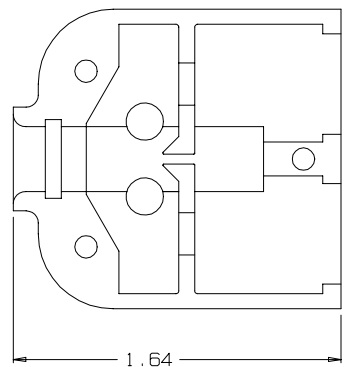
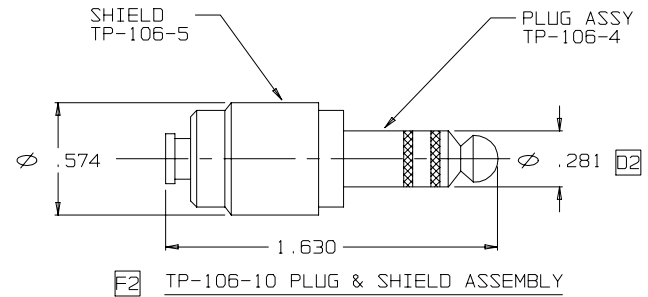
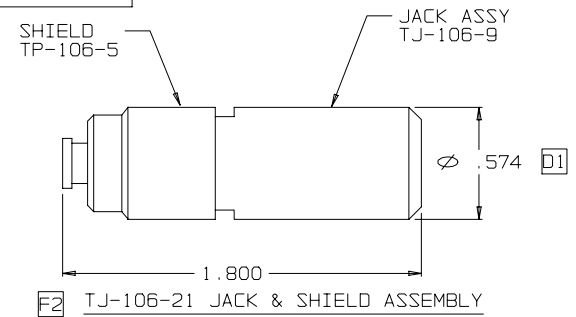
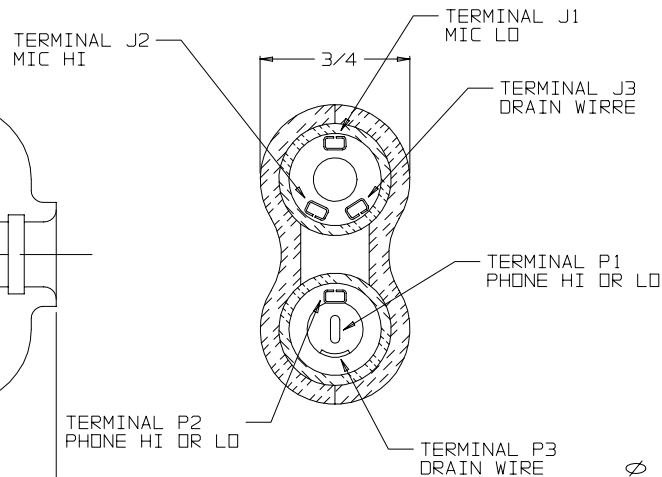
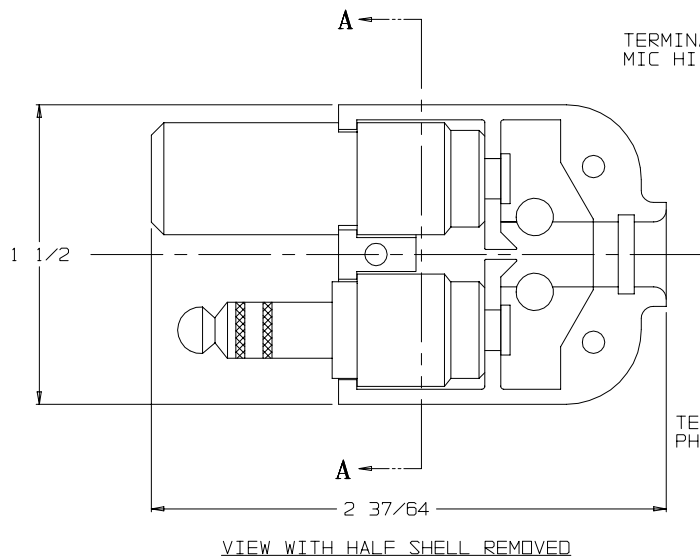

- F1** NOTES:
 1) ALL NICKEL PLATING SHALL BE OF SUFFICIENT THICKNESS TO PROVIDE CORROSION PROTECTION.
 (REF QQ-N-290-A, CLASS 1)
 2) WIRING CALL OUTS ARE FOR REF ONLY

THIS DOCUMENT CONTAINS PROPRIETARY INFORMATION OF NEXUS, INCORPORATED AND SUCH INFORMATION MAY NOT BE DISCLOSED TO OTHERS FOR ANY PURPOSE OR USED FOR ANY PURPOSE WITHOUT THE WRITTEN CONSENT OF NEXUS.

RING, STRAIN RELIEF
TJ-106-10A
(1 REQ'D)

SECTION B-B
 STRAIN RELIEF
 CLAMP TJ-106-10A
 AFTER CRIMPING
 SCALE: 4:1

F	2) ADDED P/N'S 1) MODIFIED NOTE 1&2	240	8/13/96	LS	DWN. BY	EC	DATE	4/5/93	MATERIAL	SEE FIELD OF DRAWING	
E	TJ-106-13 WAS TJS-102-10	016	8/27/96	JRJ	CHECKED BY	RVC	DATE	6/2/96	FINISH	N/A	
D	2) .564 WAS .574 1) .574 WAS .547		4/17/90	RDJ	APPR. BY	L SMITH	DATE	9/13/96	WEIGHT	SCALE 2:1	
C	WASHER P/N WAS TJ-106-13		4/8/96	RDJ	UNLESS OTHERWISE SPECIFIED DIMENSIONS ARE IN INCHES TOLERANCES ON FRACTIONS DECIMALS ANGLES					TITLE	TP-106 PLUG-TELEPHONE-BIAXIAL SHIELDED (6) CONDUCTOR
B	ADDED SECTION B-B		6/5/96	RDJ						SIZE	DWG. NO.
A	REDRAWN WAS D SIZE		3/7/96	RDJ						C	TP-106
LET.	REVISION	CN #	DATE	CHK.	±/± 1/64	±/± .005	—	DO NOT SCALE DWG.	SHEET 1 OF 1		