

Part Number:	TP143305-1	
DESCRIPTION:	Piezo Transducer	
DRAWN	CJ	8/7/2017
CHECKED	P.D.	8/9/2017
APPROVED	C.E.	8/9/2017
This document contains data proprietary to DB Unlimited. Any use or reproduction, in any form, without prior written permission of DB Unlimited is prohibited. All terms and conditions can be found at www.dbunlimitedco.com		

Top View

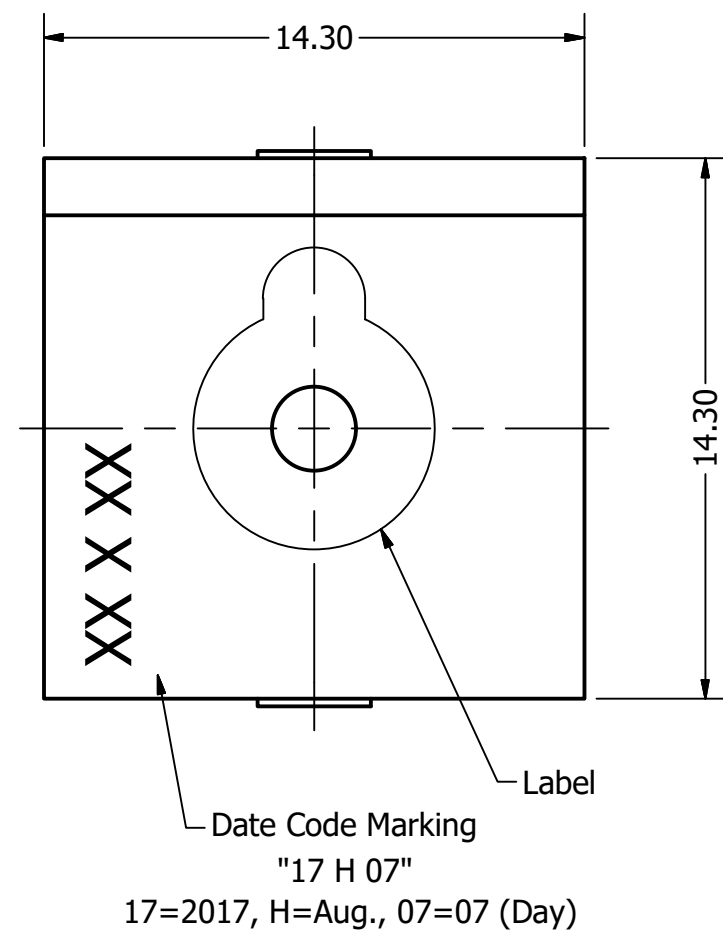

Side View

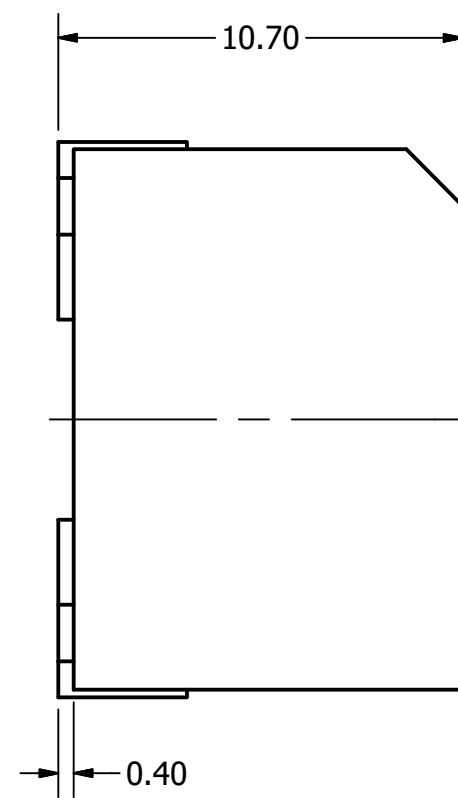

Bottom View

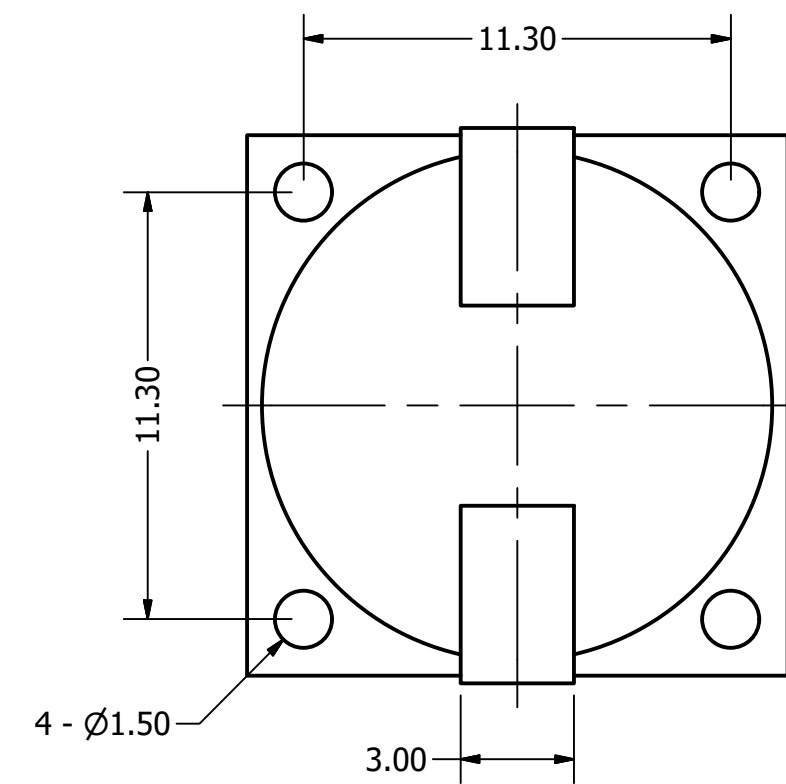

Items	Specifications	Conditions
Min. Sound Pressure Level	80	dB (@ 10cm)
Resonant Frequency	3,300	Hz
Rated Voltage	5	Vp-p
Voltage Range	1 ~ 20	Vp-p
Capacitance	15,000	pF
Max. Rated Current	5	mA
Storage Temperature	-20 ~ +70	°C
Operating Temperature	-20 ~ +70	°C
Connection Method	Surface Mount Pads	
Mount Type	Surface Mount	
Housing Material	PPS	
Weight	2	g

REVISION HISTORY			
REV	DESCRIPTION	DATE	APPROVED
	Released from Engineering	10/21/2013	J.S.
1	Updated template, new location and day added to date code	8/9/2017	C.E.

NOTES	
1) All dimensions are in mm unless otherwise noted	
2) All tolerances are ± 0.5 mm unless otherwise noted	
3) All parts meet RoHS	
4) Subject to change or redrawn without notice	