

Applications

- Quad-Band GSM850 / GSM900 / DCS / PCS
- GSM / EDGE / WEDGE Handsets
- GSM / EDGE / WEDGE Wireless Cards

Product Features

- Digital Control Interface
- Low Current At Backed-Off Power Levels
- Input Power Controlled – GMSK & 8PSK
- LB Has 4 modes – HP, MP, LP, & ULP
- HB Has 3 modes – HP, LP, & ULP
- HBT/PHEMT High Efficiency Technology
- High-Power Linearity
- Standard LB & HB Paths
- 50 Ω Input & Output Impedance
- Halogen-Free
- 11 Pin Package

General Description

The TQM7M5013 is an input power controlled, multiple gain state, quad band, GSM/EDGE PAM designed for use with the Qualcomm QTR/RTR8600 WEDGE solutions. This highly efficient PAM significantly improves talk-time while still providing an easy to use solution in a small form factor. The PA output power is controlled by the input power coming from the transceiver in both GMSK and 8PSK modes and so does not require a Vramp input. Additionally, the small 5 mm x 5 mm package requires minimum board space and allows for high levels of phone integration.

GSMK Electrical Specifications

Parameter	Typical Value				Units
	GSM850	GSM900	DCS	PCS	
HPM P _{out}	35.3	35	33.3	33	dBm
MPM P _{out}	31.8	32.2			
LPM P _{out}	22	22	22.8	22	
ULPM P _{out}	20.5	21	21.5	20	
HPM PAE	52	55	55	52	%
MPM PAE	43	45			
LPM PAE	27	31	25	19	
ULPM PAE	29	32	23	16	

Functional Block Diagram

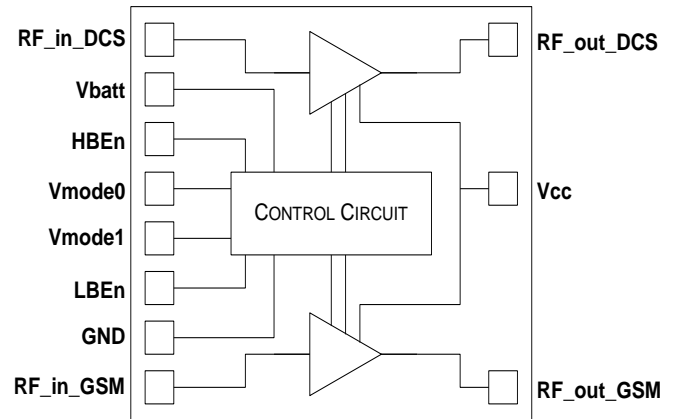

Pin Configuration

Pin No.	Label	Pin No.	Label
1	RF_in_DCS	7	GND
2	Vbatt	8	RF_in_GSM
3	HBEn	9	RF_out_GSM
4	Vmode0	10	Vcc
5	Vmode1	11	RF_out_DCS
6	LBEn	Backside Pad	GND

8PSK Electrical Specifications

Parameter	Typical Value				Units
	GSM850	GSM900	DCS	PCS	
RMS Power	29	29	28	28	dBm

Ordering Information

Part No.	Description
TQM7M5013	Quad-Band EDGE PAM
Standard T/R size = 2500 pieces on a 13" reel	