

Product Description

The TQP369185 is a general-purpose buffer amplifier that offers high dynamic range in a low-cost surface-mount package. At 1.9 GHz, the amplifier typically provides 19 dB gain, +31.7 dBm OIP3, and 4.6 dB Noise Figure while drawing 75 mA current. The device combines dependable performance with consistent quality to maintain MTTF values exceeding 100 years at mounting temperatures of +85°C. The device is housed in a lead-free/green/RoHS-compliant industry-standard SOT-89 package.

The TQP369185 consists of a Darlington-pair amplifier using Qorvo's high reliability InGaP/GaAs HBT process technology. Internal active bias enables operation with only DC-blocking capacitors and an RF choke on the DC bias feed. This broadband MMIC amplifier can be directly applied to various current and next generation wireless technologies such as CDMA, W-CDMA, and LTE. In addition, the TQP369185 will work for other various applications within the DC to 6 GHz frequency range.



SOT-89 Package

Product Features

- DC-6000 MHz
- 19 dB Gain at 1.9 GHz
- 4.7 dB Noise Figure at 1.9 GHz
- +31.7 dBm Output IP3 at 1.9 GHz
- +19.6 dBm P1dB at 1.9 GHz
- 50 Ohm Cascadable Gain Block
- Internal active bias
- SOT-89 Package

Functional Block Diagram

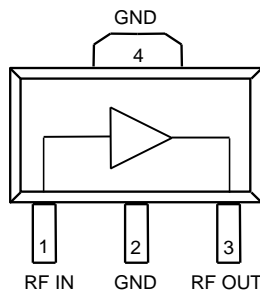

Applications

- Mobile Infrastructure
- LTE / WCDMA / CDMA
- CATV
- Point to Point
- General Purpose Wireless

Ordering Information

Part No.	Description
TQP369185	InGaP/GaAs HBT Gain Block
TQP369185-PCB	0.5-4 GHz Evaluation Board

Standard T/R size = 2500 pieces on a 13" reel

Absolute Maximum Ratings

Parameter	Rating
Storage Temperature	-55 to +150°C
RF Input Power, CW, 50 Ω, T=25 °C	+25 dBm
Device Voltage (V _{CC})	+7 V

Exceeding any one or a combination of the Absolute Maximum Rating conditions may cause permanent damage to the device. Extended application of Absolute Maximum Rating conditions to the device may reduce device reliability.

Recommended Operating Conditions

Parameter	Min	Typ	Max	Units
T _{CASE}	-40		+105	°C
T _j for >10 ⁶ hours MTTF			+170	°C

Electrical specifications are measured under bias, signal and temperature conditions as specified. Specifications are not guaranteed over all recommended operating conditions.

Electrical Specifications

Parameter	Conditions	Min	Typ	Max	Units
Operational Frequency Range		DC		6000	MHz
Test Frequency			1900		MHz
Gain		17.5	19	20.5	dB
Input Return Loss			-13.5		dB
Output Return Loss			-9.6		dB
Output P1dB			+19.6		dBm
Output IP3	P _{out} =0 dBm/tone, Δf= 1 MHz	+28	+31.7		dBm
Noise Figure			4.6		dB
Device Voltage, V _{CC}		3.0	5		V
Device Current, I _{CC}		52	75	92	mA
Thermal Resistance, θ _{Jc}	Junction to case			82	°C / W

Notes:

1. Test conditions unless otherwise noted: V_{CC}=+5 V, Temp=+25 °C, 50 Ω system
2. OIP3 is measured with two tones at an output power of 4 dBm / tone separated by 1 MHz. The suppression on the largest IM3 product is used to calculate the OIP3 using 2:1 rule. 2:1 rule gives relative value with respect to fundamental tone.

S-Parameters

Freq (MHz)	S11 (dB)	S11 (ang)	S21 (dB)	S21 (ang)	S12 (dB)	S12 (ang)	S22 (dB)	S22 (ang)
10	-19.3	-178.5	21.3	179.4	-26.2	0.5	-14.3	3.2
20	-19.0	-177.3	21.4	178.6	-26.1	0.5	-14.0	1.0
50	-18.6	-175.6	21.4	177.6	-26.0	-0.4	-14.3	-2.7
100	-18.4	-176.9	21.3	174.5	-26.1	-0.3	-14.4	-8.5
200	-17.9	-170.6	21.3	169.7	-26.1	-0.6	-14.0	-16.2
500	-16.9	-169.8	21.0	155.4	-26.0	-2.7	-13.4	-43.7
1000	-14.3	-173.6	20.5	132.9	-25.6	-6.1	-12.0	-83.8
1500	-12.3	178.7	20.0	110.6	-25.1	-10.7	-10.4	-119.2
2000	-10.7	163.5	19.3	89.1	-24.5	-18.4	-8.9	-149.9
2500	-9.1	148.7	18.5	68.1	-24.2	-26.3	-7.9	-177.8
3000	-7.8	136.2	17.7	49.2	-23.8	-34.8	-7.0	160.8
3500	-6.9	125.7	16.8	30.8	-23.5	-44.4	-6.3	141.0
4000	-6.5	115.7	15.8	12.5	-23.5	-53.7	-5.3	122.0
4500	-6.7	101.4	14.7	-4.6	-23.7	-62.5	-5.0	104.1
5000	-5.8	89.6	13.7	-19.6	-23.5	-69.4	-4.7	90.3
5500	-4.8	80.2	13.1	-36.1	-23.5	-79.2	-4.1	78.6
6000	-4.3	69.8	12.1	-52.3	-23.7	-89.4	-4.0	66.0

Notes:

1. Test Conditions: $V_{CC}=+5\text{ V}$ (typ.), $I_{CC}=72\text{ mA}$ (typ.), $T=+25\text{ }^{\circ}\text{C}$, unmatched 50 ohm system, calibrated to device leads

TQP369185-PCB Evaluation Board

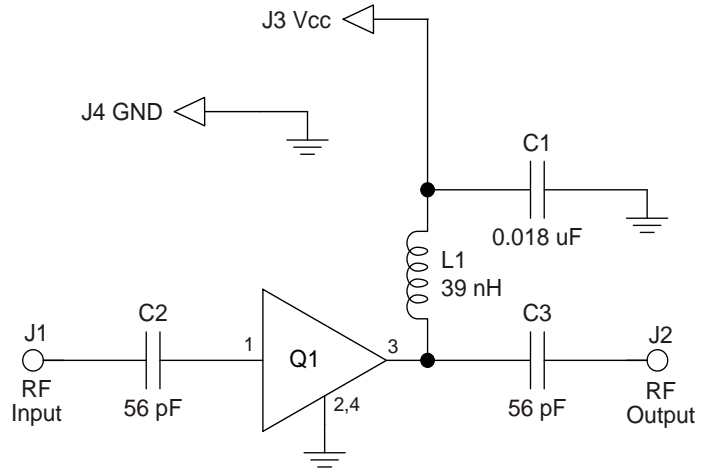
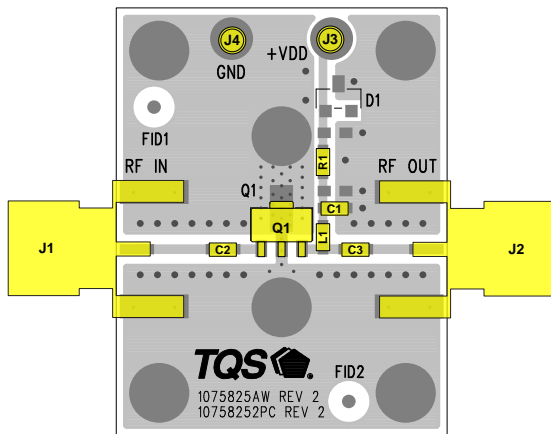

Notes:

1. See PC Board Layout, under Application Information section, for more information.
2. All components are of 0603 size unless stated on the schematic.
3. Zero Ohm resistor R1 is used to bridge a trace gap on PCB 1075825 and is not required in end user applications.

Bill of Material – TQP369185-PCB

Reference Des.	Value	Description	Manuf.	Part Number
Q1	n/a	High Linearity LNA Gain Block	Qorvo	TQP369185
C1	0.018 uF	Cap, Chip, 0603, 16V, X7R, 10%	various	
C2, C3	56 pF	Cap, Chip, 0603, 50V, NPO, 5%	various	
L1	39 nH	Inductor, 0603, 5%, CS Series	Coilcraft	
R1	0 Ω	Res, Chip, 603, 1/10W, 5%	various	

Component Values for Specific Frequencies

Use the component values in this table for optimal operation at specific frequencies.

Reference Designator	Frequency (MHz)						
	50	500	900	1900	2200	2500	3500
L1	820 nH	220 nH	68 nH	27 nH	22 nH	18 nH	15 nH
C2, C3	.018 uF	1000 pF	100 pF	68 pF	68 pF	56 pF	39 pF

Typical Performance – TQP369185-PCB

Test conditions unless otherwise noted: $V_{SUPPLY} = +5\text{ V}$, $I_{CC} = 75\text{ mA}$, $T_{CASE} = +25^\circ\text{C}$

Parameter	Typical Value										Units
Frequency	500	900	1900	2100	2600	3500	4000	5000	6000		MHz
Gain	20.5	20.4	19.0	18.6	18.0	16.8	15.8	13.7	12.1		dB
Input Return Loss	11.7	12.4	12.3	13.3	13.7	-6.9	-6.5	-5.8	-4.3		dB
Output Return Loss	17.8	15.9	10	9.3	8.7	-6.3	-5.3	-4.7	-4		dB
Output P1dB	20.9	+19.8	+19.6	+19.5	+19	+17.5	+15.8	+13.9	+12.3		dBm
OIP3	+33.3	+32.3	+31.7	+31.7	+30.6	+28.6	+27.1	+24.4	+23.4		dBm
Noise Figure	4.5	4.7	4.6	4.7	4.8	4.9	5.1	5.6	6.3		dB

Notes:

- OIP3 measured with two tones at an output power of 0 dBm / tone separated by 1 MHz.

Performance Plots – TQP369185-PCB

Test conditions unless otherwise noted: $V_{SUPPLY} = +5\text{ V}$, $I_{CC} = 75\text{ mA}$, $T_{CASE} = +25^\circ\text{C}$

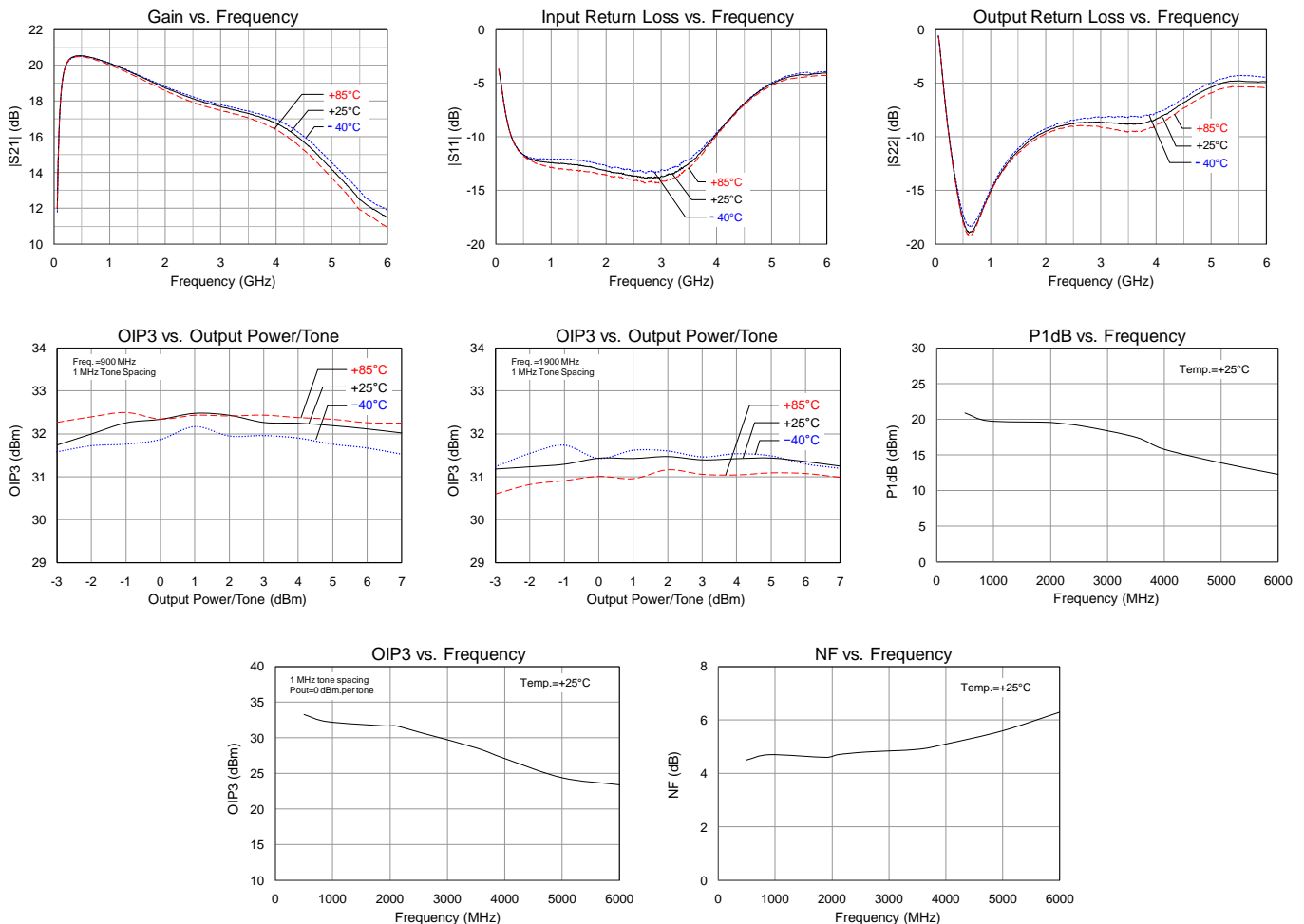

Pin Configuration and Description

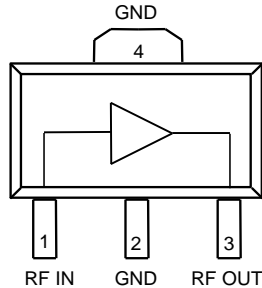

Pin No.	Label	Description
1	RF IN	RF Input, matched to 50 ohms. External DC Block is required.
3	RFOUT	RF output / DC supply, matched to 50 ohms. External DC Block and bias choke, are required.
2, 4, Backside Paddle	GND Paddle	RF/DC ground. Use recommended via pattern to minimize inductance and thermal resistance. See PCB Mounting Pattern for suggested footprint.

Applications Information

Qorvo PCB 1075825 Material and Stack-up

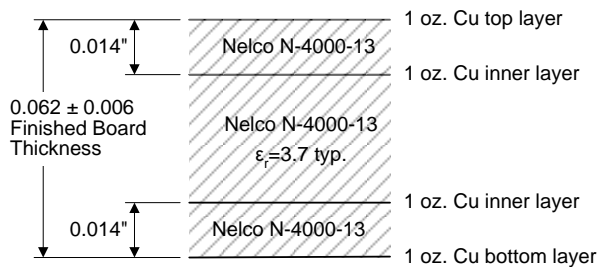

50 Ohm Line Dimensions: width=0.028"
spacing=0.028"

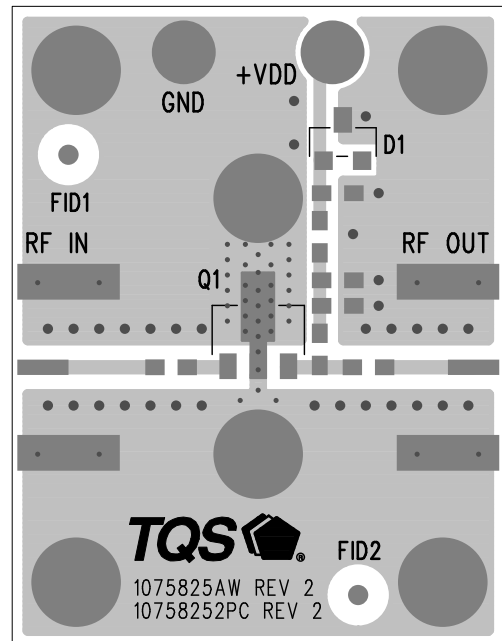

Package Marking and Dimensions

Marking: Part number – 369185
Lot code – XXXX

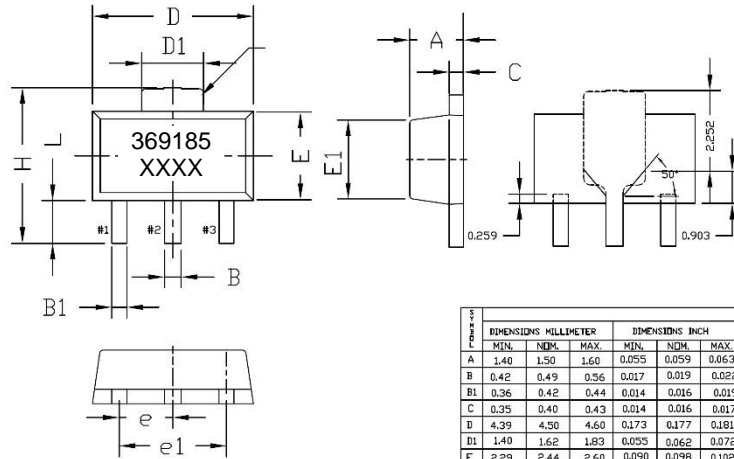

	DIMENSIONS MILLIMETER			DIMENSIONS INCH		
	MIN.	NOM.	MAX.	MIN.	NOM.	MAX.
A	1.40	1.50	1.60	0.055	0.059	0.063
B	0.42	0.49	0.56	0.017	0.019	0.022
B1	0.36	0.42	0.44	0.014	0.016	0.019
C	0.35	0.40	0.43	0.014	0.016	0.017
D	4.39	4.50	4.60	0.173	0.177	0.181
D1	1.40	1.62	1.83	0.055	0.062	0.072
E	2.29	2.44	2.60	0.090	0.098	0.102
E1	1.77	2.03	2.29	0.070	0.074	0.090
e	1.50 BSC			0.059 BSC		
e1	3.00 BSC			0.118 BSC		
H	3.84	4.04	4.25	0.151	0.155	0.167
L	0.74	0.97	1.20	0.029	0.041	0.047

Notes:

1. All dimensions are in millimeters. Angles are in degrees.
2. Dimension and tolerance formats conform to ASME Y14.4M-1994.
3. The terminal #1 identifier and terminal numbering conform to JESD 95-1 SPP-012.
4. Contact plating: NiPdAu

PCB Mounting Pattern

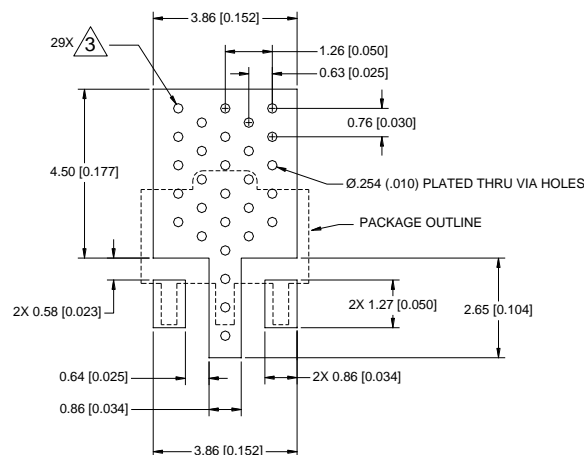

Notes:

1. All dimensions are in millimeters. Angles are in degrees.
2. Use 1 oz. copper minimum for top and bottom layer metal.
3. Vias are required under the backside paddle of this device for proper RF/DC grounding and thermal dissipation.
4. Do not remove or minimize via hole structure in the PCB. Thermal and RF grounding is critical.
5. We recommend a 0.35mm (#80/.0135") diameter bit for drilling via holes and a final plated thru diameter of 0.25 mm (0.01").
6. Ensure good package backside paddle solder attach for reliable operation and best electrical performance.

Tape and Reel Information – Carrier and Cover Tape Dimensions

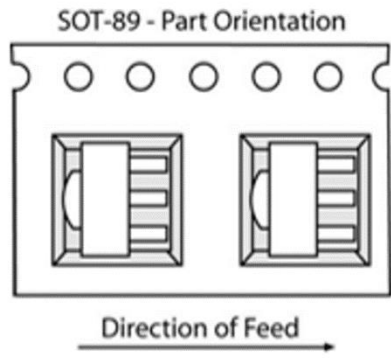
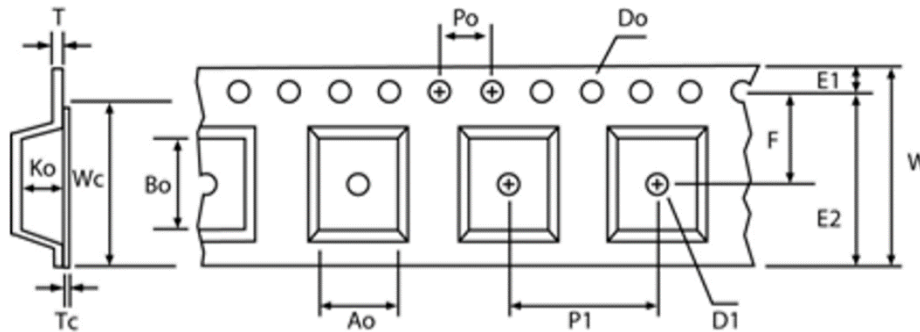

Feature	Measure	Symbol	Size (in)	Size (mm)
Cavity	Length	A0	0.181	4.60
	Width	B0	0.193	4.90
	Depth	K0	0.075	1.90
	Pitch	P1	0.315	8.00
Centerline Distance	Cavity to Perforation - Length Direction	P2	0.079	2.00
	Cavity to Perforation - Width Direction	F	0.217	5.50
Cover Tape	Width	C	0.362	9.20
Carrier Tape	Width	W	0.472	12.0

Tape and Reel Information – Reel Dimensions

Standard T/R size = 2,500 pieces on a 13" reel.

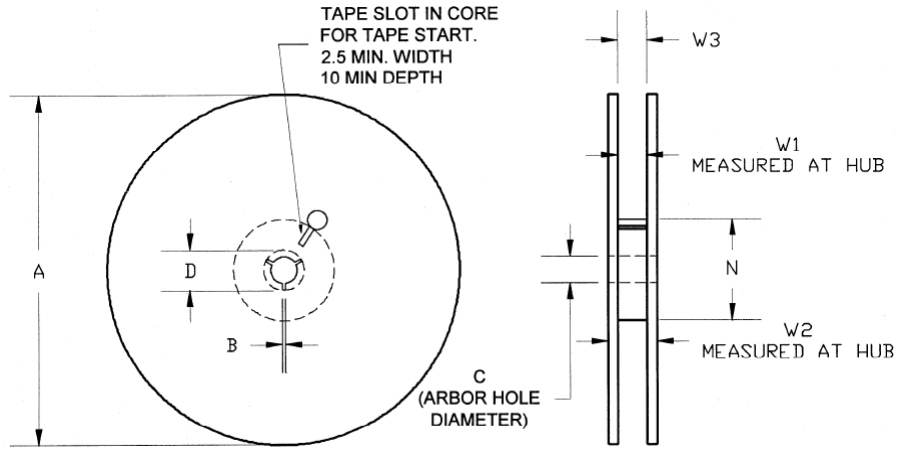

Feature	Measure	Symbol	Size (in)	Size (mm)
Flange	Diameter	A	6.969	170.0
	Thickness	W2	0.717	18.2
	Space Between Flange	W1	0.504	12.8
Hub	Outer Diameter	N	2.283	58.0
	Arbor Hole Diameter	C	0.512	13.0
	Key Slit Width	B	0.079	2.0
	Key Slit Diameter	D	0.787	20.0

Tape and Reel Information – Tape Length and Label Placement



- Notes:
1. Empty part cavities at the trailing and leading ends are sealed with cover tape. See EIA 481-1-A.
 2. Labels are placed on the flange opposite the sprockets in the carrier tape.