



# TQP3M9009

## High Linearity LNA Gain Block



3-pin SOT- 89 Package

### General Description

The TQP3M9009 is a cascade-able, high linearity gain block amplifier in a low-cost surface-mount package. At 1.9 GHz, the amplifier is targeted to provide 21.8 dB gain, +39.5 dBm OIP3, and 1.3 dB Noise Figure while only drawing 125 mA current. The device is housed in a leadfree/green/RoHS-compliant industry-standard SOT-89 package.

The TQP3M9009 has the benefit of having high gain across a broad range of frequencies while also providing very low noise. This allows the device to be used in both receiver and transmitter chains for high performance systems. The amplifier is internally matched using a high performance E-pHEMT process and only requires an external RF choke and blocking/bypass capacitors for operation from a single +5V supply. The internal active bias circuit also enables stable operation over bias and temperature variations.

The TQP3M9009 covers the 0.05 – 4 GHz frequency band and is targeted for wireless infrastructure or other applications requiring high linearity and/or low noise figure.

### Functional Block Diagram

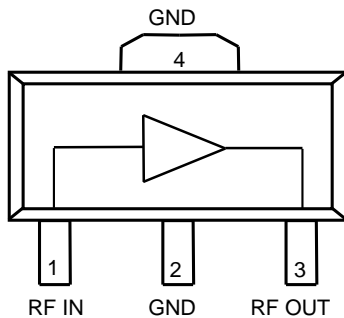

### Product Features

- 50 – 4000 MHz
- 21.8 dB Gain At 1.9 GHz
- +39.5 dBm Output IP3
- 1.3 dB Noise Figure At 1.9 GHz
- 50 Ohm Cascade-able Gain Block
- Unconditionally Stable
- High input power capability
- +5V Single Supply, 125 mA Current
- SOT-89 Package

### Applications

- Repeaters
- Mobile Infrastructure
- LTE / WCDMA / EDGE / CDMA
- General Purpose Wireless

### Ordering Information

Part No.	Description
TQP3M9009	High Linearity LNA Gain Block
TQP3M9009-PCB_IF	0.05 – 0.5 GHz Evaluation Board
TQP3M9009-PCB_RF	0.5 – 4 GHz Evaluation Board

Standard T/R size = 1000 pieces on a 7" reel

## Absolute Maximum Ratings

Parameter	Rating
Storage Temperature	-65 to +150 °C
RF Input Power, CW, 50 Ω, T=25 °C	+23 dBm
Device Voltage (V <sub>DD</sub> )	+7 V
Reverse Device Voltage	-0.3 V

Exceeding any one or a combination of the Absolute Maximum Rating conditions may cause permanent damage to the device.

## Recommended Operating Conditions

Parameter	Min	Typ	Max	Units
Device Voltage (V <sub>DD</sub> )	+3.0	+5.0	+5.25	V
T <sub>CASE</sub>	-40		+105	°C
T <sub>j</sub> for >10 <sup>6</sup> hours MTTF			+190	°C

Electrical specifications are measured at specified test conditions. Specifications are not guaranteed over all recommended operating conditions. Application of conditions to the device outside the Recommended Operating Conditions may reduce device reliability and performance.

## Electrical Specifications

Test conditions unless otherwise noted: V<sub>DD</sub>=+5 V, Temp=+25 °C, 50 Ω system

Parameter	Conditions	Min	Typ	Max	Units
Operational Frequency Range		50		4000	MHz
Test Frequency			1900		MHz
Gain		20	21.8	23	dB
Input Return Loss			13		dB
Output Return Loss			14		dB
Output P1dB			+22		dBm
Output IP3	P <sub>out</sub> =+3 dBm / tone, Δf=1 MHz	+36.5	+39.5		dBm
Noise Figure			1.3		dB
Current, I <sub>DD</sub>			125	150	mA
Thermal Resistance, θ <sub>jc</sub>	Junction to case			34	°C/W

## S-Parameters

Test Conditions:  $V_{DD}=+5\text{ V}$ ,  $I_{DD}=125\text{ mA}$ ,  $T=+25\text{ }^{\circ}\text{C}$ ,  $50\ \Omega$  system, calibrated to device leads

Freq (MHz)	S11 (dB)	S11 (ang)	S21 (dB)	S21 (ang)	S12 (dB)	S12 (ang)	S22 (dB)	S22 (ang)
50	-16.66	-149.04	27.36	171.55	-29.65	1.22	-13.56	179.33
100	-14.86	-157.51	27.12	166.00	-29.37	-1.50	-13.09	174.97
200	-13.56	-165.34	26.70	156.36	-29.26	-5.67	-12.78	159.12
400	-12.51	-173.30	26.14	137.87	-29.42	-14.20	-13.06	133.47
600	-11.37	178.88	25.53	119.50	-29.63	-21.58	-13.69	110.30
800	-10.40	169.81	24.85	102.41	-30.03	-28.26	-14.46	86.04
1000	-9.76	160.89	24.16	86.01	-30.28	-35.35	-15.64	62.04
1200	-9.31	150.48	23.40	70.36	-30.96	-40.26	-16.58	37.31
1400	-8.84	139.39	22.82	55.48	-31.05	-46.78	-17.14	11.49
1600	-8.51	128.52	22.31	41.20	-31.76	-51.29	-17.34	-12.33
1800	-8.33	116.42	21.66	27.52	-2.00	-58.53	-17.04	-33.75
2000	-8.16	104.69	21.23	13.67	-32.50	-63.59	-16.80	-57.05
2200	-8.01	92.36	20.82	0.68	-33.07	-66.83	-16.28	-76.12
2400	-8.06	79.88	20.33	-13.12	-33.72	-72.40	-15.48	-95.17
2600	-8.13	66.42	20.02	-26.88	-34.02	-77.18	-14.43	-113.34
2800	-8.14	51.54	19.74	-41.54	-34.42	-81.16	-13.66	-128.34
3000	-8.00	35.02	19.52	-55.82	-35.18	-86.54	-12.61	-142.44
3200	-8.13	17.50	19.28	-71.00	-36.25	-88.92	-11.99	-157.55
3400	-7.86	-3.63	19.10	-87.06	-36.83	-94.66	-11.31	-167.91
3600	-7.65	-26.69	18.91	-103.86	-37.20	-96.43	-10.62	-179.13
3800	-7.20	-52.39	18.59	-121.75	-38.27	-102.65	-10.05	170.24
4000	-6.39	-79.22	18.17	-140.35	-39.25	-102.05	-9.83	159.78

**TQP3M9009-PCB\_IF / RF Evaluation Board**

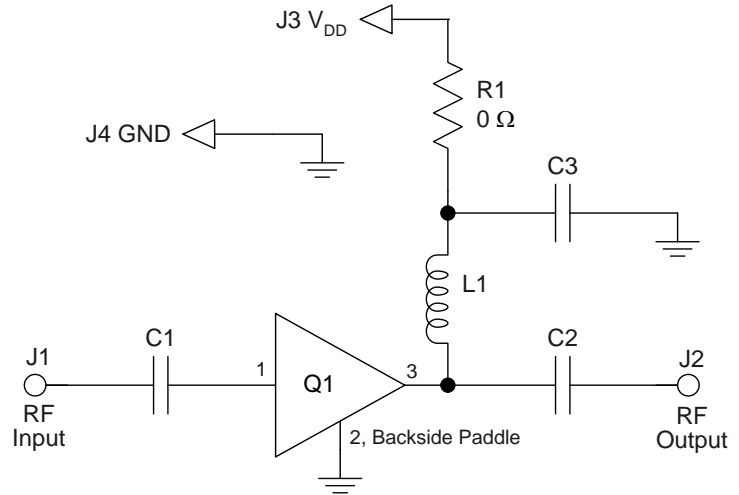
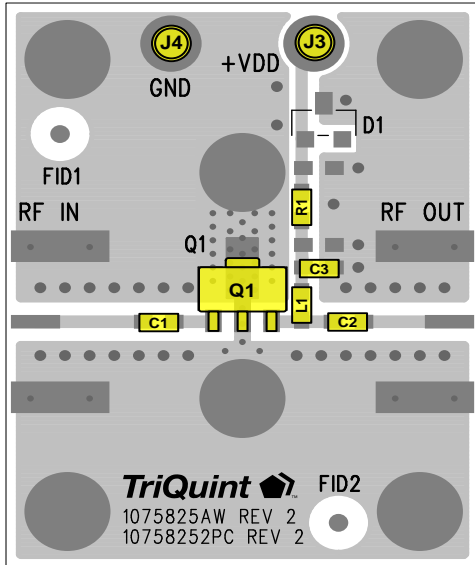

**Notes:**

1. See PC Board Layout, page 8 for more information.
2. Components shown on the silkscreen but not on the schematic are not used.
3. R1 (0 Ω jumper) may be replaced with copper trace in the target application layout.
4. The recommended component values are dependent upon the frequency of operation.
5. All components are of 0603 size unless stated on the schematic.

**Bill of Material – TQP3M9009-PCB\_IF / RF**

Reference Designation	TQP3M9009-PCB_IF	TQP3M9009-PCB_RF
	50 – 500 MHz	500 – 4000 MHz
Q1	TQP3M9009	TQP3M9009
C1, C2	1000 pF	100 pF
C3	0.01 uF	0.01 uF
L1	330 nH	68 nH
D1	Do Not Place	
R1	0 Ω	

Performance can be optimized at frequency of interest by using recommended component values shown in the table below.

Reference Designation	Frequency (MHz)			
	500	2000	2500	3500
C1, C2	100 pF	22 pF	22 pF	22 pF
L1	82 nH	22 nH	18 nH	15 nH

## Typical Performance – TQP3M9009-PCB\_RF

Test conditions unless otherwise noted:  $V_{DD}=+5\text{ V}$ ,  $I_{DD}=125\text{ mA}$ ,  $\text{Temp}=+25\text{ }^{\circ}\text{C}$ ,  $50\ \Omega$  system.

Parameter	Typical Value						Units
Frequency	500	900	1900	2700	3500	4000	MHz
Gain	25.7	24.7	21.8	20	18.9	18	dB
Input Return Loss	12	12	13	13	8	6	dB
Output Return Loss	11	13	14	10	10	11.5	dB
Output P1dB	+22.5	+21.8	+22	+21.6	+21.8	+20.7	dBm
OIP3 <sup>(1)</sup>	+41.4	+40.5	+39.5	+39	+37.9	+35.8	dBm
Noise figure <sup>(2)</sup>	0.9	0.9	1.3	1.7	2.1	2.4	dB

Notes:

1. OIP3 measured with two tones at an output power of +3 dBm / tone separated by 1 MHz.
2. Noise figure values in the table above includes board losses. Approx. =0.1dB at 2 GHz.

## Performance Plots – TQP3M9009-PCB\_RF

Test conditions unless otherwise noted:  $V_{DD}=+5\text{ V}$ ,  $I_{DD}=125\text{ mA}$ ,  $\text{Temp}=+25\text{ }^{\circ}\text{C}$ ,  $50\ \Omega$  system.

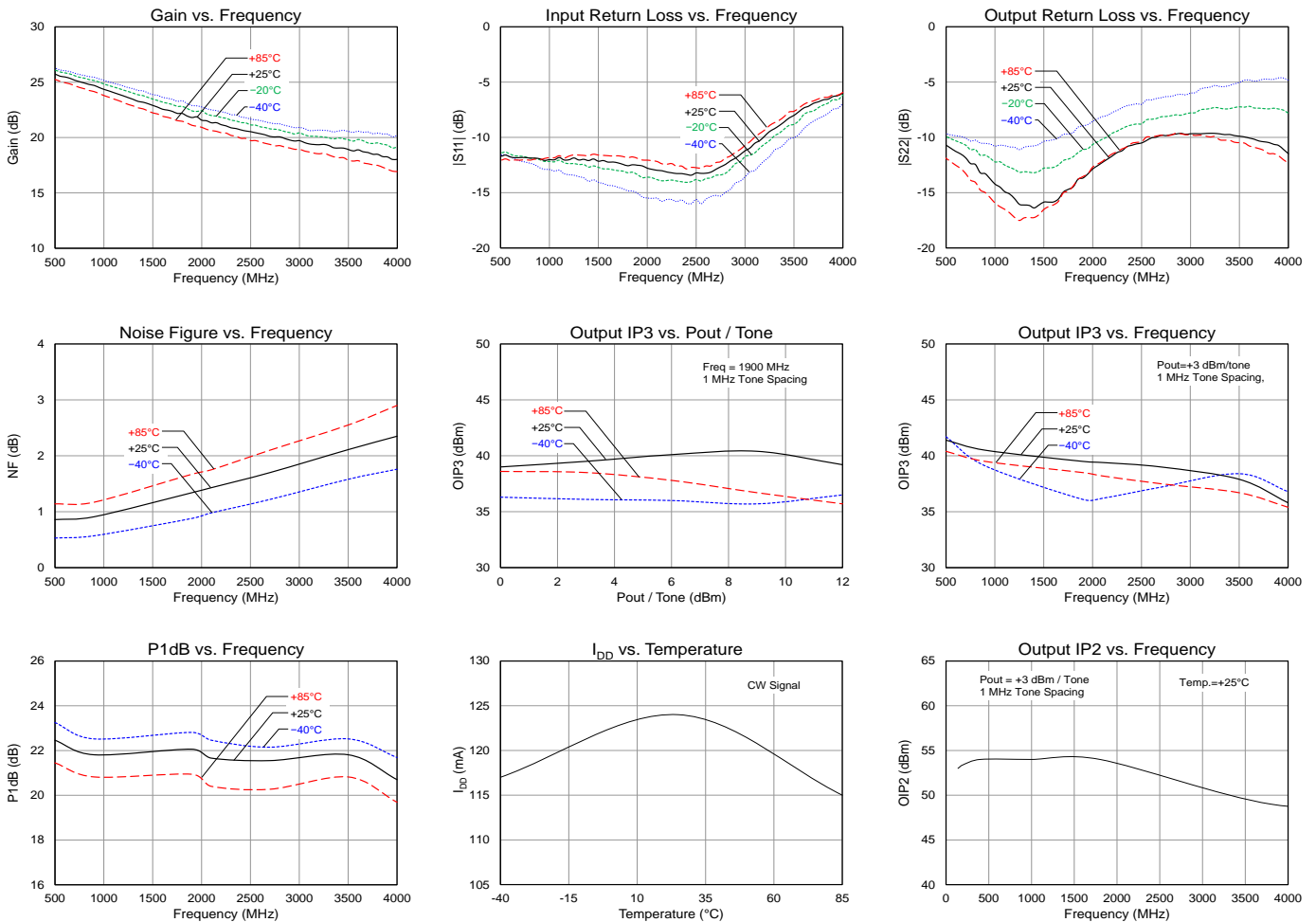

**Performance Plots – TQP3M9009-PCB\_RF (contd.)**

Test conditions unless otherwise noted:  $V_{DD}=+5\text{ V}$ ,  $I_{DD}=125\text{ mA}$ ,  $\text{Temp.}=+25\text{ }^\circ\text{C}$ ,  $50\ \Omega$  system.

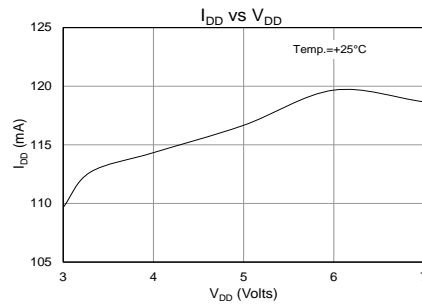
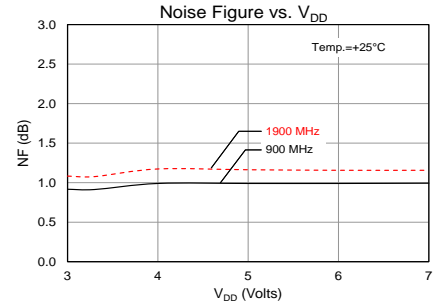
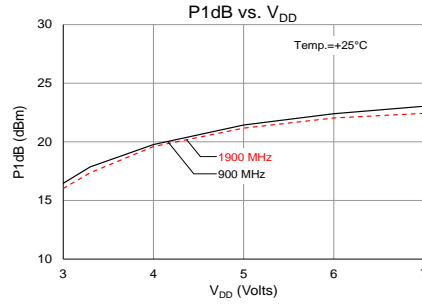
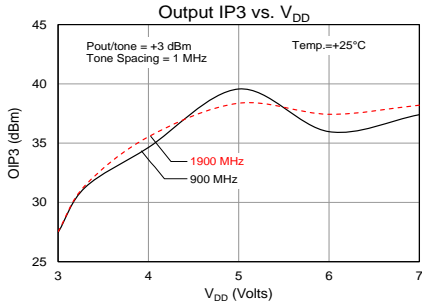

## Typical Performance – TQP3M9009-PCB\_IF

Test conditions unless otherwise noted:  $V_{DD}=+5\text{ V}$ ,  $I_{DD}=125\text{ mA}$ ,  $\text{Temp}=+25\text{ }^{\circ}\text{C}$ ,  $50\ \Omega$  system.

Parameter	Typical Value				Units
Frequency	70	100	200	500	MHz
Gain	27	26.8	26.4	25.8	dB
Input Return Loss	12	13	13	13	dB
Output Return Loss	11	11	12	13	dB
Output P1dB	+21.6	+21.9	+21.9	+22.2	dBm
OIP3 <sup>(1)</sup>	+37.6	+38.8	+39	+41.4	dBm
Noise figure <sup>(2)</sup>	1.4	1.3	0.9	0.9	dB

Notes:

- OIP3 measured with two tones at an output power of +3 dBm / tone separated by 1 MHz.
- Noise figure values in the table above includes board losses. Approx. =0.1 dB at 2 GHz.

## Performance Plots – TQP3M9009-PCB\_IF

Test conditions unless otherwise noted:  $V_{DD}=+5\text{ V}$ ,  $I_{DD}=125\text{ mA}$ ,  $\text{Temp}=+25\text{ }^{\circ}\text{C}$ ,  $50\ \Omega$  system.

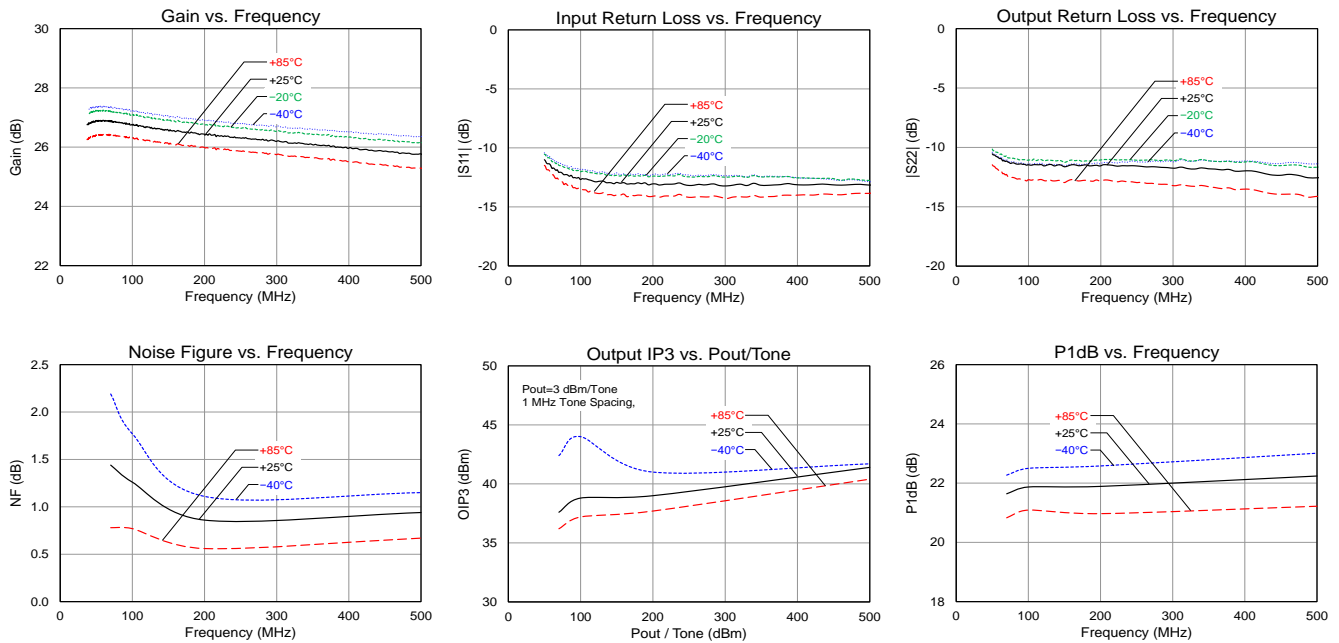

**Pin Configuration and Description**

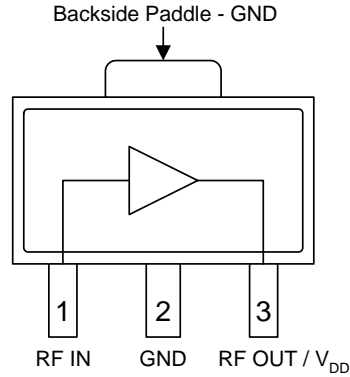

Pin No.	Label	Description
1	RF IN	RF input; matched to 50 ohms. External DC Block is required.
2, Backside Paddle	GND	RF/DC ground. Use recommended via pattern to minimize inductance and thermal resistance. See PCB Mounting Pattern for suggested footprint.
3	RF OUT / V <sub>DD</sub>	RF output, matched to 50 ohms. External DC Block and bias voltage required.

**Evaluation Board PCB Information**

Qorvo PCB 1075825 Material and Stack-up

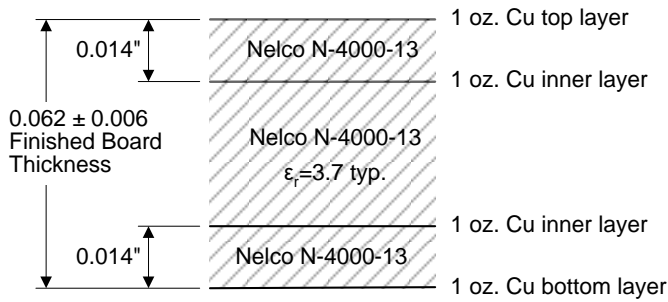

50 ohm line dimensions: width = .028", spacing = .028"

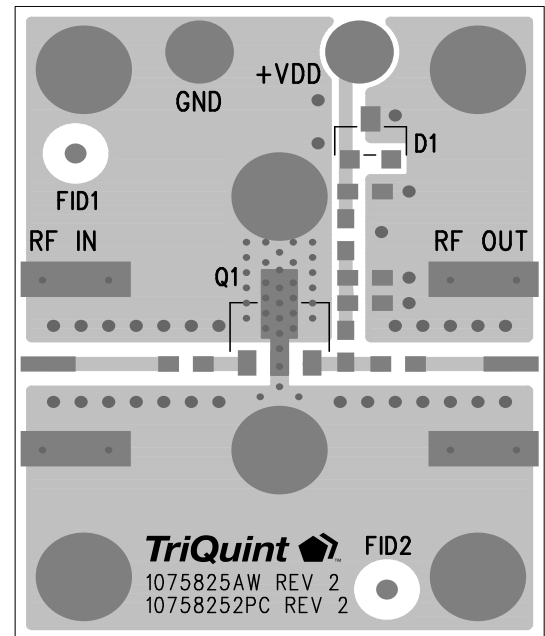



## Package Marking and Dimensions

Marking: Product Identifier: 3M9009  
Lot Code: XXXX – Assigned by sub-contractor

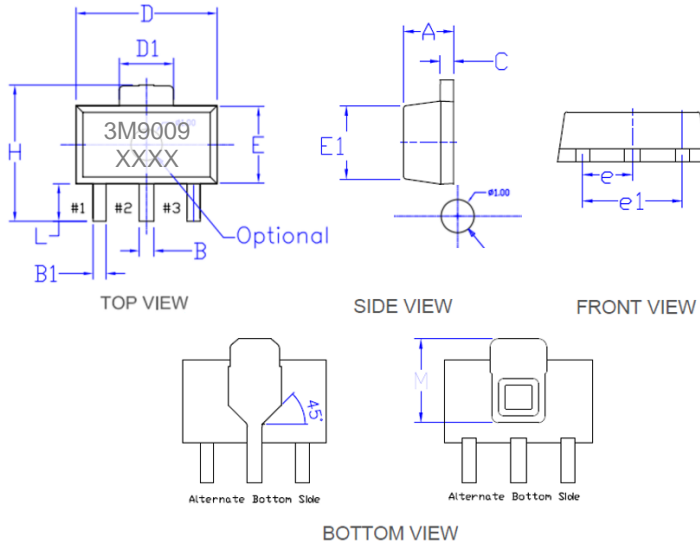

SYMBOLS	DIMENSIONS IN MILLIMETERS		
	MIN	NOM	MAX
A	1.40	1.50	1.60
B	0.41	0.49	0.58
B1	0.34	0.42	0.50
C	0.35	0.40	0.44
D	4.40	4.50	4.60
D1	1.40	1.67	1.83
E	2.30	2.50	2.60
E1	1.77	2.31	2.57
e	1.45	1.50	1.55
e1	2.90	3.00	3.10
H	3.94	4.10	4.25
L	0.80	1.05	1.20
M	2.36 ref		

- Notes:
1. The terminal #1 identifier and terminal numbering conform to JESD 95-1 SPP-012.
  2. Trace code up to 4 characters to be assigned by sub-contractor.

## PCB Mounting Pattern

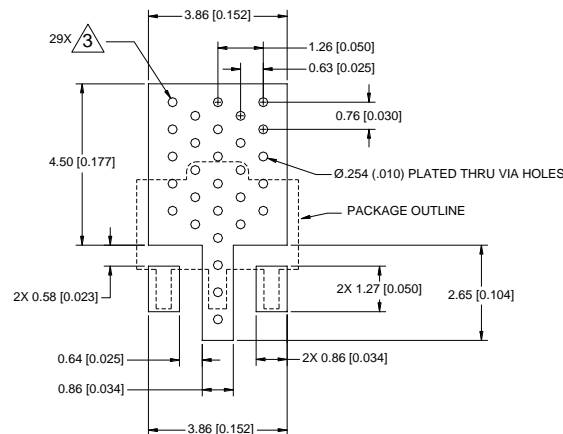

- Notes:
1. All dimensions are in millimeters[inches]. Angles are in degrees.
  2. Use 1 oz. copper minimum for top and bottom layer metal.
  3. Via holes are required under the backside paddle of this device for proper RF/DC grounding and thermal dissipation. We recommend a 0.35mm (#80/.0135") diameter bit for drilling via holes and a final plated thru diameter of 0.25mm (0.01").
  4. Ensure good package backside paddle solder attach for reliable operation and best electrical performance.

Tape and Reel Information – Carrier and Cover Tape Dimensions

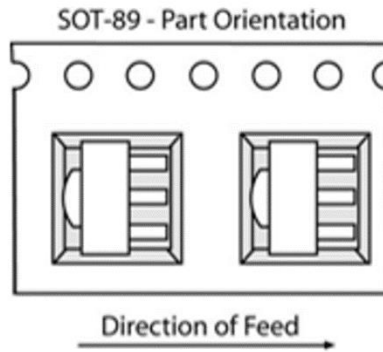
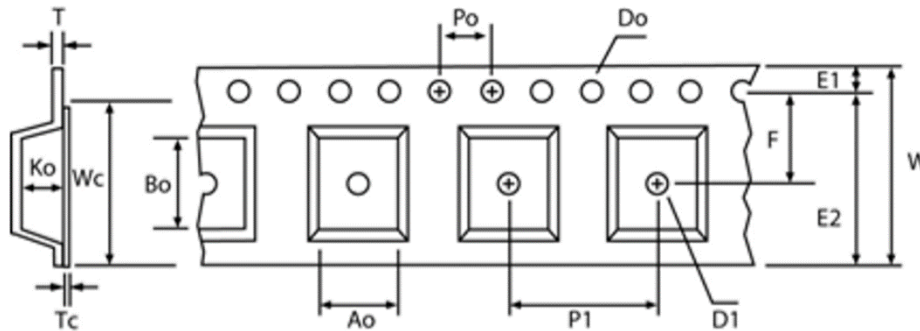

Feature	Measure	Symbol	Size (in)	Size (mm)
Cavity	Length	A0	0.181	4.60
	Width	B0	0.193	4.90
	Depth	K0	0.075	1.90
	Pitch	P1	0.315	8.00
Centerline Distance	Cavity to Perforation - Length Direction	P2	0.079	2.00
	Cavity to Perforation - Width Direction	F	0.217	5.50
Cover Tape	Width	C	0.362	9.20
Carrier Tape	Width	W	0.472	12.0

**Tape and Reel Information – Reel Dimensions**

Standard T/R size = 1,000 pieces on a 7" reel.

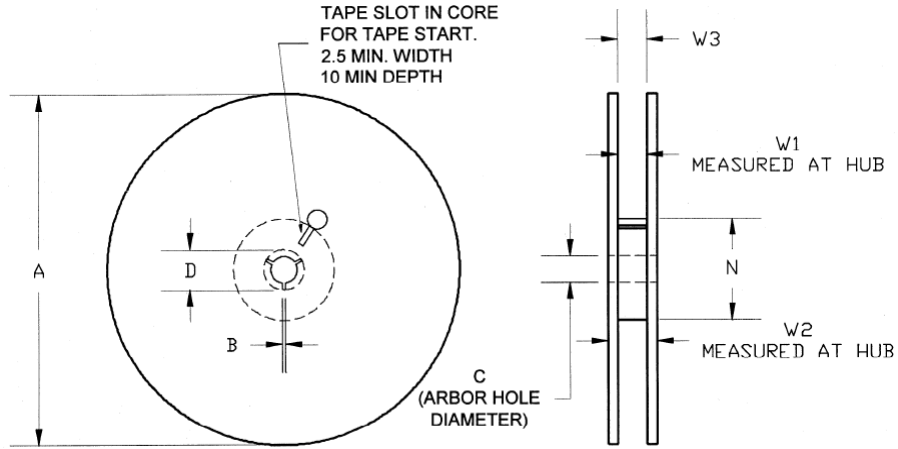

Feature	Measure	Symbol	Size (in)	Size (mm)
Flange	Diameter	A	6.969	170.0
	Thickness	W2	0.717	18.2
	Space Between Flange	W1	0.504	12.8
Hub	Outer Diameter	N	2.283	58.0
	Arbor Hole Diameter	C	0.512	13.0
	Key Slit Width	B	0.079	2.0
	Key Slit Diameter	D	0.787	20.0

**Tape and Reel Information – Tape Length and Label Placement**

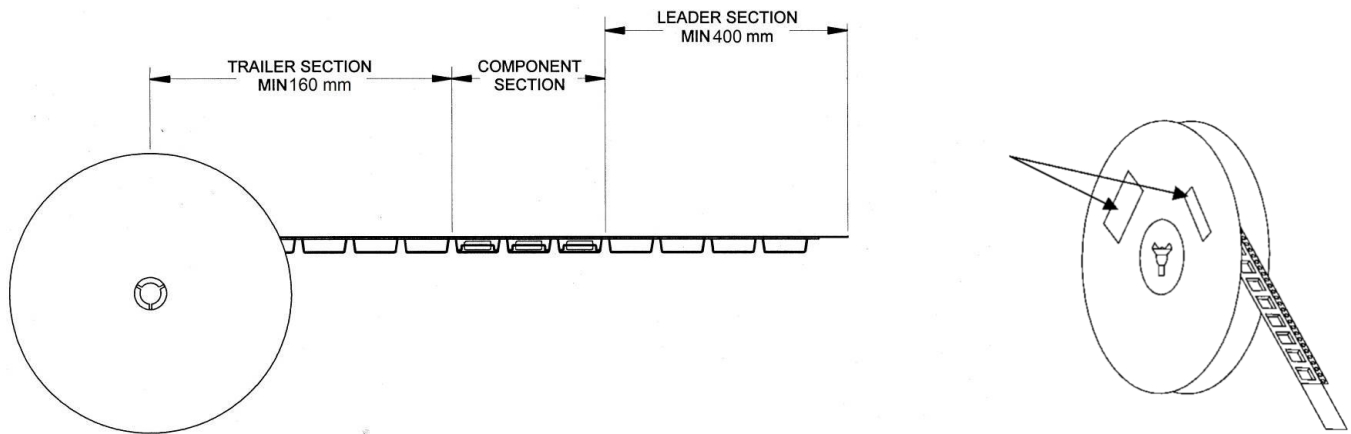

- Notes:
1. Empty part cavities at the trailing and leading ends are sealed with cover tape. See EIA 481-1-A.
  2. Labels are placed on the flange opposite the sprockets in the carrier tape.