

### General Description

The TQP9221 is a high-linearity two-stage power amplifier in a low-cost surface-mount package with on-chip bias control and temperature compensation circuits. The amplifier provides 30.5 dB gain over the 2010 – 2200 MHz frequency range and be utilized without the need of linearization circuitry such as DPD It is able to achieve -49 dBc ACLR at +24 dBm output power using 20 MHz LTE signal (9.5 dB PAR).

The TQP9221 integrates two high performance amplifier stages onto a module to allow for a compact system design and requires very few external components for operation. The product is bias adjustable allowing the amplifier's power consumption to be optimized and is available in a lead-free/RoHS-compliant 7 x 7 mm surface mount package.

The TQP9221 is targeted for small cell or enterprise Femtocell basestation applications, distributed antenna systems (DAS), repeaters, and/or booster amplifiers.

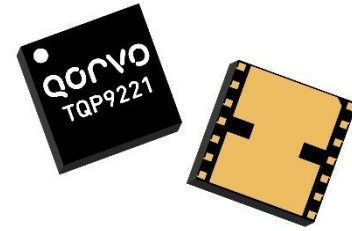

14 Pin 7 x 7 mm Leadless SMT Package

### Product Features

- 2010 – 2200 MHz Frequency Range
- Fully integrated, 2-Stage Power Amplifier
- Internally Matched 50 Ω Input & Output
- -49 dBc ACLR at Pavg = +24 dBm
- 30.5 dB Gain
- 15% PAE at +24 dBm
- 220 mA Quiescent Current
- On-chip Control Bias and Temp. Comp Circuit
- RoHS compliant
- Covers Bands 1, 4, 10, 23, 34, 66

### Functional Block Diagram

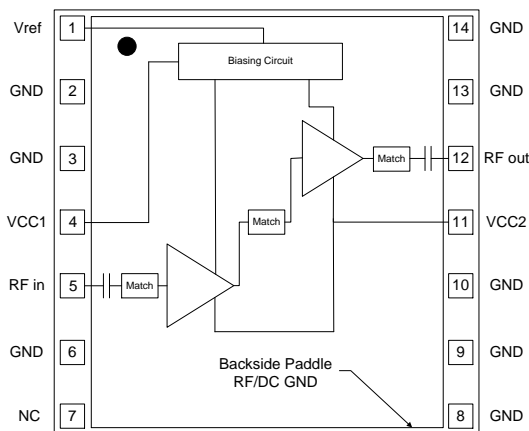

Top View

### Applications

- Small Cell / Picocell
- Enterprise Femtocell
- Customer Premises Equipment (CPE)
- Data Cards and Terminals
- Distributed Antenna Systems (DAS)
- Booster Amps, Repeater

### Ordering Information

Part No.	Description
TQP9221	2,500 pieces on a 13" reel (standard)
TQP9221-PCB	2.11 –2.17 GHz Evaluation Board

### Absolute Maximum Ratings

Parameter	Rating
Storage Temperature	-55 to +150 °C
RF Input Power, CW, 50Ω, T=+25 °C	+13 dBm
Supply Voltage (V <sub>CC</sub> )	6 V
V <sub>REF</sub>	+3.5 V

Exceeding any one or a combination of the Absolute Maximum Rating conditions may cause permanent damage to the device. Extended application of Absolute Maximum Rating conditions to the device may reduce device reliability.

### Recommended Operating Conditions

Parameter	Min	Typ	Max	Units
V <sub>CC1</sub> , V <sub>CC2</sub>	+3.6	+4.5	+5.25	V
V <sub>ref</sub>	+2.75	+2.85	+2.95	V
T <sub>CASE</sub>	-40		+85	°C
T <sub>j</sub> at T <sub>CASE</sub> max			+165	°C

Electrical specifications are measured at specified test conditions. Specifications are not guaranteed over all recommended operating conditions.

### Electrical Specifications

Parameter	Conditions <sup>(1)</sup>	Min	Typ	Max	Units
Frequency Range		2010		2200	MHz
Test Frequency			2140		MHz
Gain		27.5	30.5	34.5	dB
Input Return Loss		7	10		dB
Output Return Loss		9	12		dB
Output P1dB			+33		dBm
ACLR	P <sub>out</sub> = +24 dBm, 20 MHz LTE E-TM1.1, 9.5 dB PAR		-49	-45	dBc
ACLR	P <sub>out</sub> = +24 dBm, 2X20 MHz LTE E-TM1.1, 9.5 dB PAR		-43		dBc
ACLR	P <sub>out</sub> = +24 dBm, 15 MHz LTE E-TM1.1, 9.5 dB PAR		-51		dBc
ACLR	P <sub>out</sub> = +24 dBm, 10 MHz LTE E-TM1.1, 9.5 dB PAR		-51		dBc
ACLR	P <sub>out</sub> = +24 dBm, 5 MHz LTE E-TM1.1, 9.5 dB PAR		-51		dBc
Power Added Efficiency	P <sub>out</sub> = +24 dBm, 20 MHz LTE E-TM1.1, 9.5 dB PAR	13	15.2		%
Spurious Output Level	P <sub>out</sub> = +24 dBm, 10:1 VSWR		<60		dBc
VSWR Survivability	No degradation or failure	10:1			VSWR
Quiescent Current	V <sub>CC1</sub> + V <sub>CC2</sub>	160	220	280	mA
Reference Current	Temp = -40°C to +85°C, V <sub>REF</sub> = +2.85V		6.5	10	mA
Leakage current	V <sub>CC</sub> = +4.5V, V <sub>ref</sub> = 0V		1.5	5	μA
Operational Current	P <sub>out</sub> = +24 dBm		365	460	mA
Switching Time	10% to 90% Rise time		620		nSec
	90% to 10% Fall time		840		nSec
Harmonics	2F <sub>0</sub> at +24dBm, CW signal		-37	-32	dBc
	3F <sub>0</sub> at +24dBm, CW signal		-52	-47	dBc
	4F <sub>0</sub> at +24dBm, CW signal		-60	-55	dBc
Thermal Resistance, θ <sub>JC</sub>	Module (junction to case)			37	°C/W

Notes:

1. Test conditions unless otherwise noted: V<sub>CC1</sub> = V<sub>CC2</sub> = +4.5V, V<sub>REF</sub> = +2.85V, Temp = +25 °C, 50 Ω system.

### Evaluation Board – TQP9221-PCB

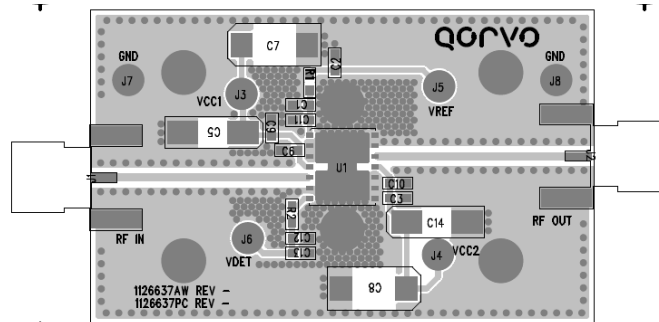
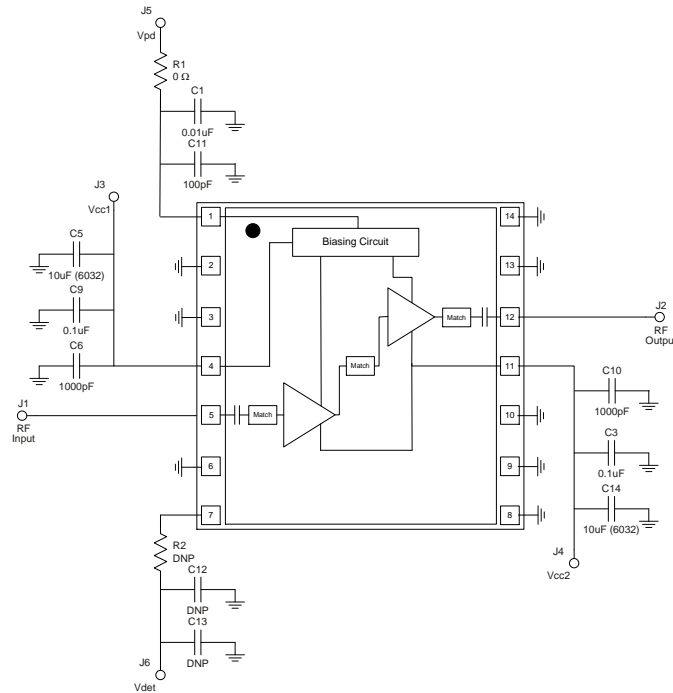

### Bill of Material – TQP9221-PCB

Reference Des.	Value	Description	Manuf.	Part Number
-	-	Printed Circuit Board	Qorvo	1126637
U1	-	High Linearity 0.25 W Power Amplifier	Qorvo	TQP9221
R1	0 Ω	Resistor, Chip, 0603, 5%	various	
C1	0.01 µF	Capacitor, Chip, 0603, 5%	various	
C11	100 pF	Capacitor, Chip, 0603, 5%	various	
C3, C9	0.1 µF	Capacitor, Chip, 0603, 5%	various	
C5, C14	10 µF	Capacitor, Chip, 6032, 10%, Tantalum	various	
C6, C10	1000 pF	Capacitor, Chip, 0603, NPO/COG, 5%	various	

### Typical Performance

Parameter	Conditions	-40°C	+25°C	+85°C	Units
Gain	Small Signal	32	30.5	29.0	dB
ACLR	P <sub>OUT</sub> = +24 dBm, 20 MHz LTE E-TM1.1, 9.5dB PAR	-51	-49	-47	dBc
PAE	P <sub>OUT</sub> = +24 dBm, 20 MHz LTE E-TM1.1, 9.5dB PAR	16	15	14	%

Test Frequency = 2140MHz

LTE signal BW	5MHz	10MHz	15MHz	20MHz	Units
ACLR1-Low	-50.0	-50.5	-50.5	-50.0	dBc
ACLR1-high	-50.0	-50.0	-50.0	-50.0	dBc

V<sub>CC1</sub>=V<sub>CC2</sub>=4.5V, P<sub>out</sub>=24.5dBm, Signal PAR=9.5dB, F = 2140MHz

### Performance Plots – TQP9221-PCB

Test conditions unless otherwise noted: V<sub>CC1</sub> = V<sub>CC2</sub> = +4.5V, V<sub>REF</sub> = +2.85 V, I<sub>CQ</sub> = 220mA, I<sub>REF</sub> = 6.5mA, Temp.= +25 °C

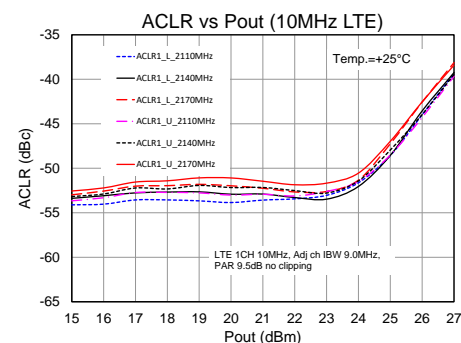
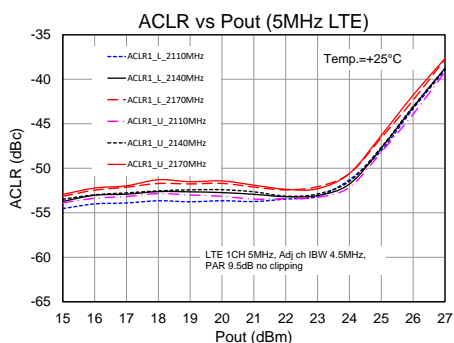
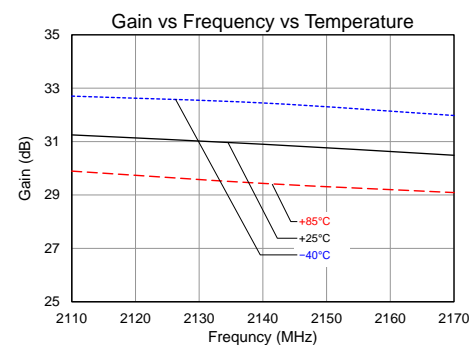
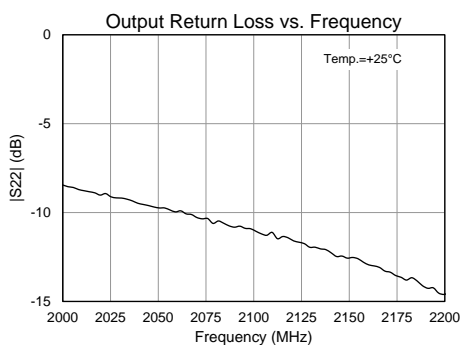
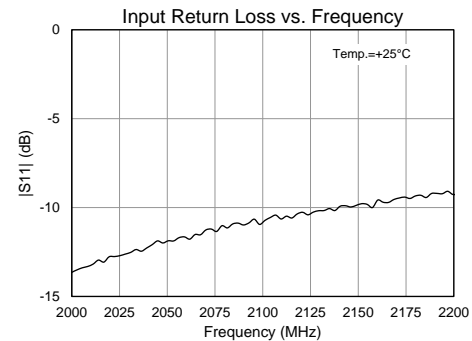
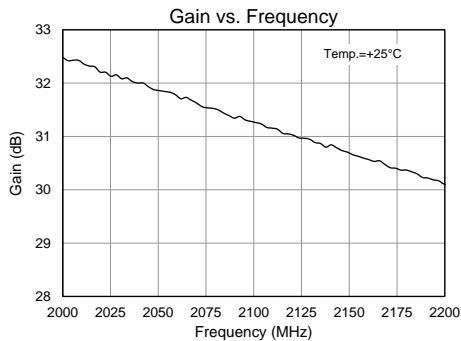

### Performance Plots – TQP9221-PCB

Test conditions unless otherwise noted:  $V_{CC1} = V_{CC2} = +4.5V$ ,  $V_{REF} = +2.85V$ ,  $I_{CQ} = 220mA$ ,  $I_{REF} = 6.5mA$ ,  $Temp. = +25^{\circ}C$

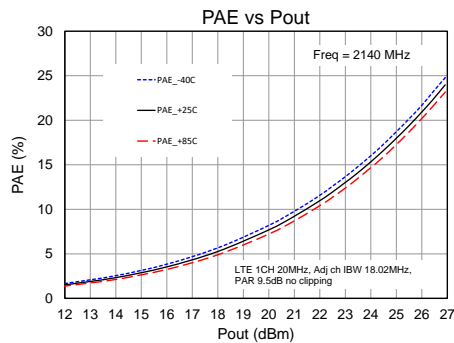
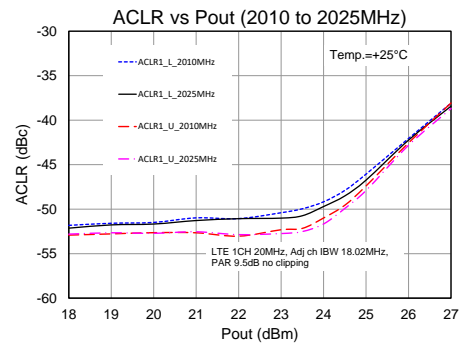
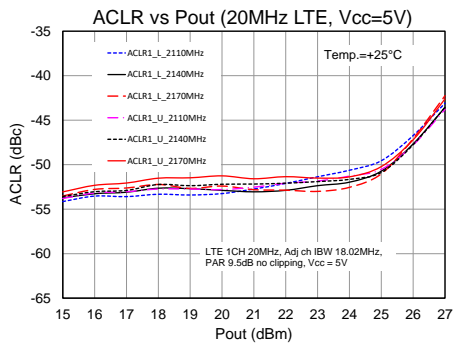
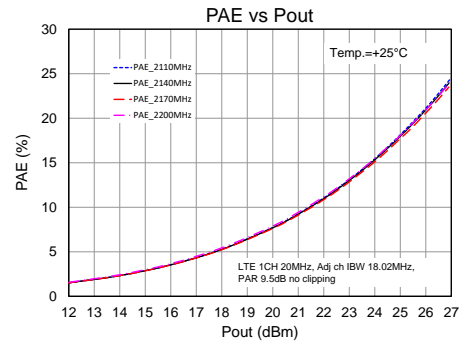
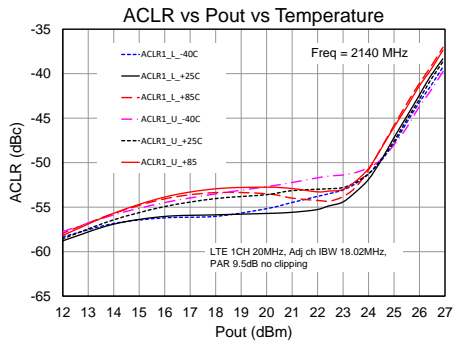
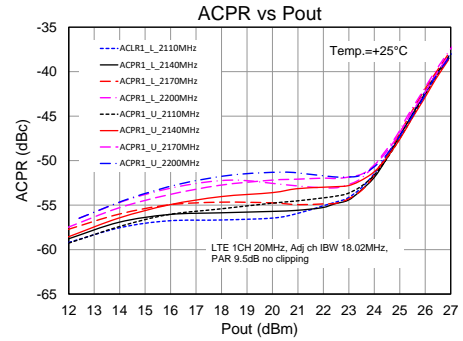
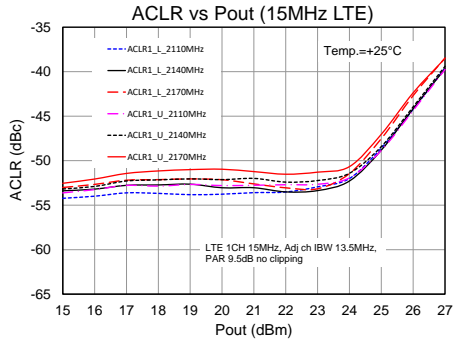

### Switching Time

#### Switching Time Measurement based on TQP9221 Application Board

Using Shutdown Circuit:  $V_{REF}=2.85V$ ,  $V_{CC}=4.5V$ ,  $C_1=NL$

Parameter	
Turn-on Transition (10% RF – 90% RF)	620nS
Turn-off Transition (90% RF – 10% RF)	840nS

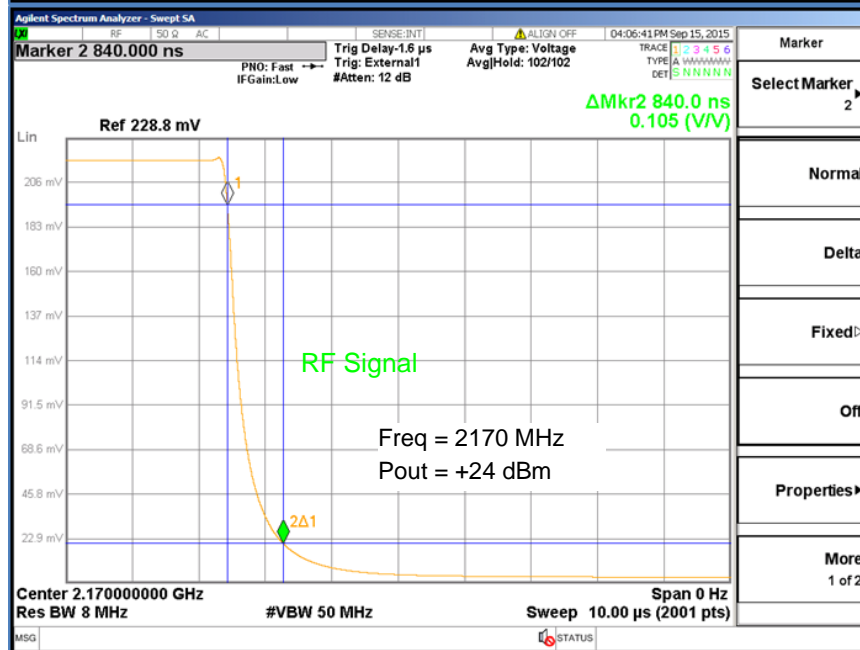
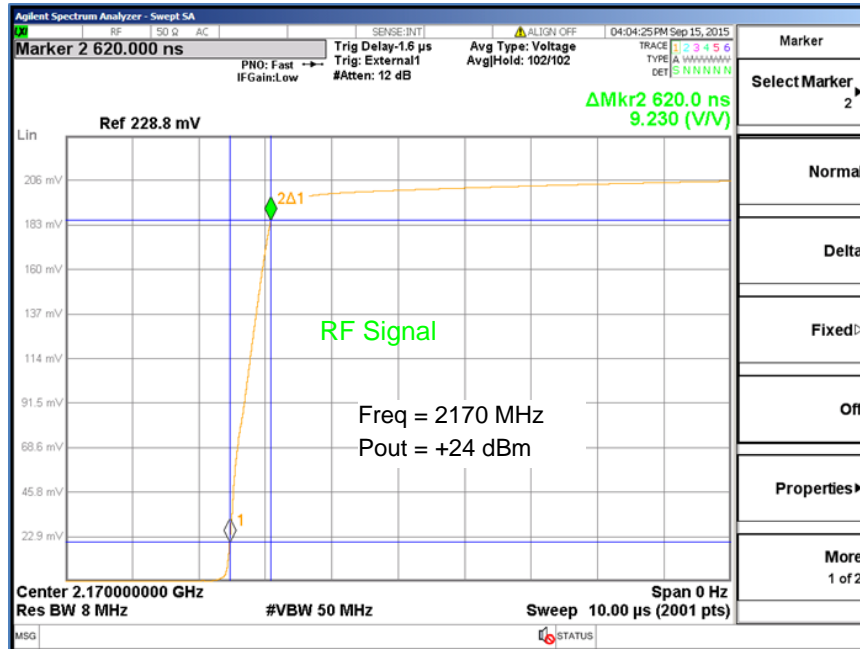

### Pin Configuration and Description

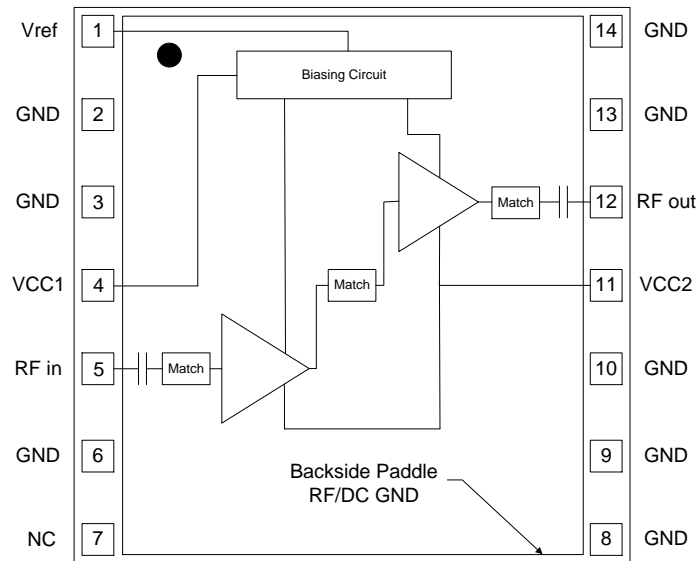

Top View

Pad No.	Label	Description
1	V <sub>REF</sub>	Sets the bias current for the amplifiers. It can also be used to power down the device.
2, 3, 6, 8, 9, 10, 13, 14	GND	RF and DC ground.
4	VCC1	Voltage supply for the active bias circuitry.
5	RF in	RF input pin. The DC is internally blocked at this pin.
7	NC	No internal connection.
11	VCC2	DC voltage supply connection for AMP1 and AMP2.
12	RF out	RF output pin. The DC is internally blocked at this pin.
Backside Paddle	RF/DC GND	RF/DC ground. See PCB Mounting Pattern for suggested footprint.

### Evaluation Board PCB Information

#### Qorvo PCB 1126637 Material and Stack-up

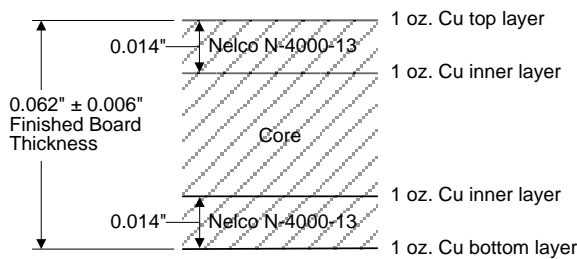

50 Ω line dimensions: width = .028"  
spacing = .028".

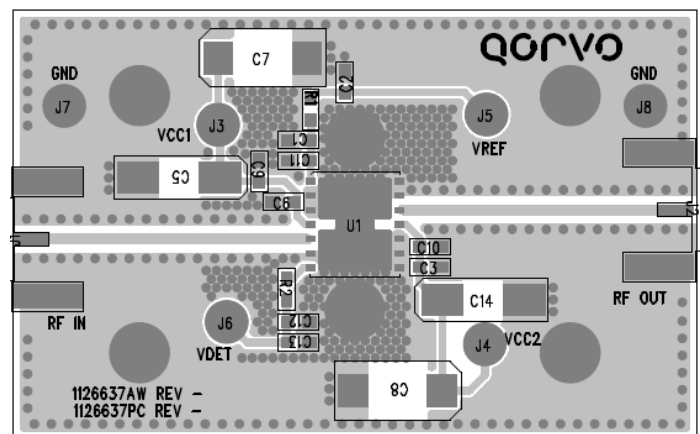

### Package Marking and Dimensions

Marking: Part number – TQP9221  
 Assembly Code – YYWW  
 Country Code - CCCC  
 Lot code – AaXXXX

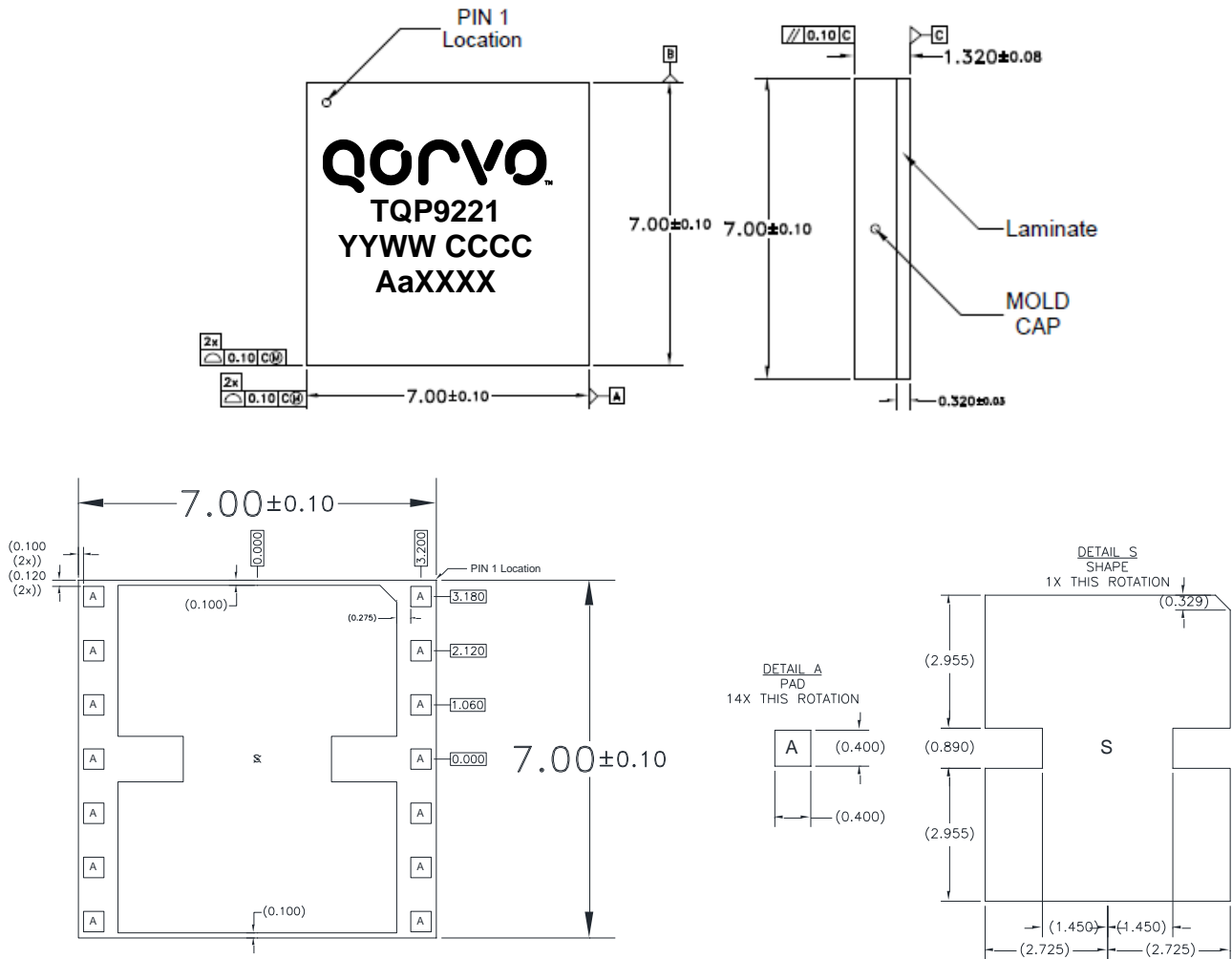

**Notes:**

1. All dimensions are in millimeters. Angles are in degrees.
2. Dimension and tolerance formats conform to ASME Y14.4M-1994.
3. The terminal #1 identifier and terminal numbering conform to JESD 95-1 SPP-012.



### PCB Mounting Pattern

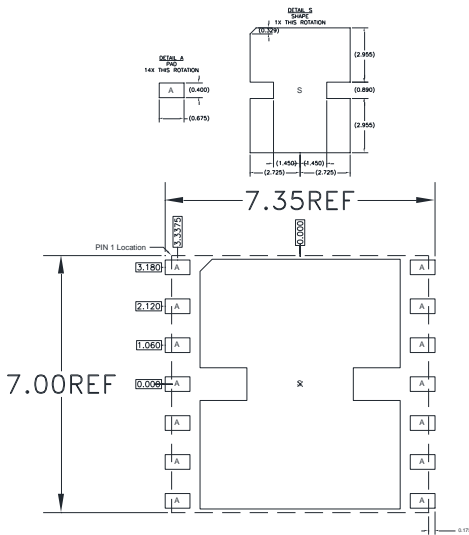

RECOMMENDED  
LAND PATTERN

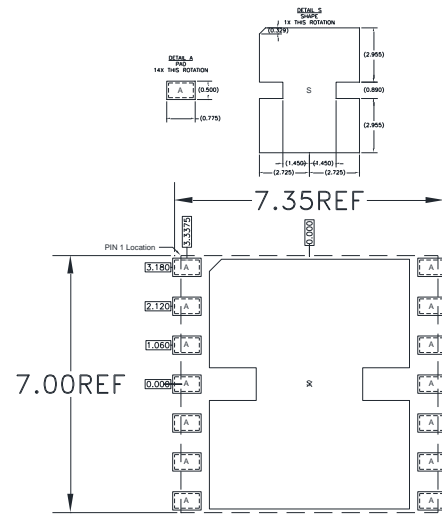

RECOMMENDED  
LAND PATTERN MASK

Notes:

1. All dimensions are in millimeters. Angles are in degrees.
2. Use 1 oz. copper minimum for top and bottom layer metal.
3. Via holes are required under the backside paddle of this device for proper RF/DC grounding and thermal dissipation. We recommend a 0.35mm (#80/.0135") diameter bit for drilling via holes and a final plated thru diameter of 0.25 mm (0.010").
4. Ensure good package backside paddle solder attach for reliable operation and best electrical performance.

**Tape and Reel Information – Carrier and Cover Tape Dimensions**

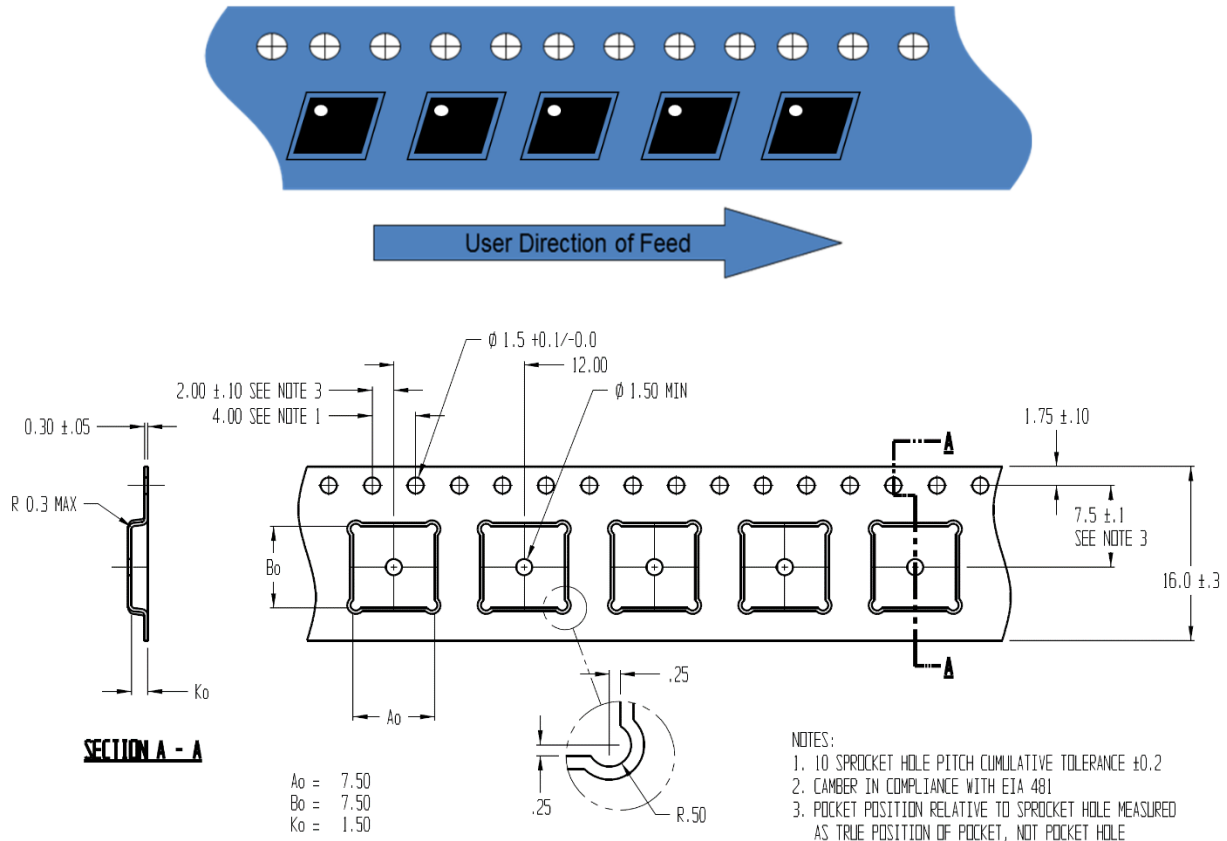

Feature	Measure	Symbol	Size (in)	Size (mm)
Cavity	Length	A0	0.295	7.50
	Width	B0	0.295	7.50
	Depth	K0	0.059	1.50
	Pitch	P1	0.472	12.00
Centerline Distance	Cavity to Perforation - Length Direction	P2	0.079	2.00
	Cavity to Perforation - Width Direction	F	0.295	7.50
Cover Tape	Width	C	0.524	13.30
Carrier Tape	Width	W	0.630	16.0

### Tape and Reel Information – Reel Dimensions (13")

Standard T/R size = 2,500 pieces on a 13" reel.

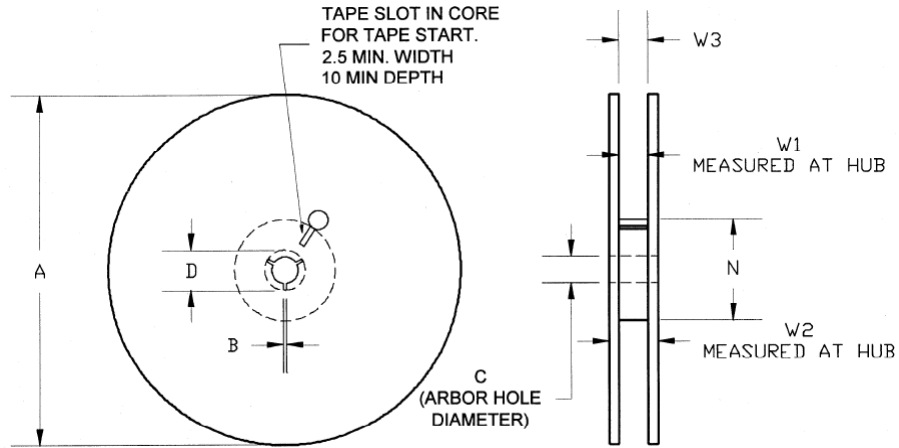

Feature	Measure	Symbol	Size (in)	Size (mm)
Flange	Diameter	A	12.992	330.0
	Thickness	W2	0.874	22.2
	Space Between Flange	W1	0.661	16.8
Hub	Outer Diameter	N	4.016	102.0
	Arbor Hole Diameter	C	0.512	13.0
	Key Slit Width	B	0.079	2.0
	Key Slit Diameter	D	0.787	20.0

### Tape and Reel Information – Tape Length and Label Placement

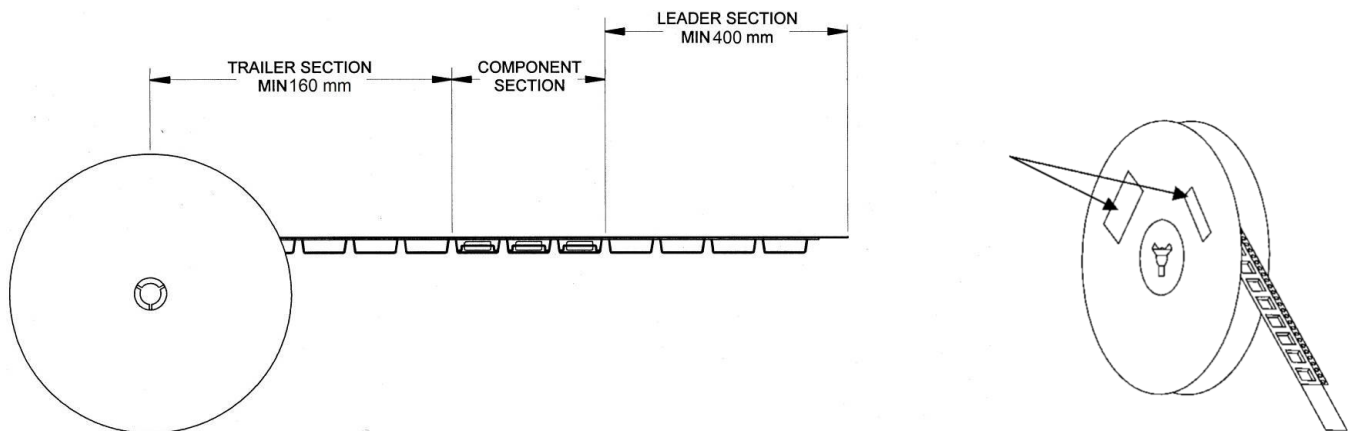

**Notes:**

1. Empty part cavities at the trailing and leading ends are sealed with cover tape. See EIA 481-1-A.
2. Labels are placed on the flange opposite the sprockets in the carrier tape.