



QPQ1285

TDD B41 Band Pass Filter – 194 MHz

General Description

The QPQ1285 is an exceptionally high performance BAW Filter for sub-Band 41 uplink / downlink. This filter is housed in a compact 2x1.6 mm package for base station applications.

Low insertion loss, coupled with high attenuation makes this filter an ideal choice for TDD Macro Cells and Small Cells.

The QPQ1285 is part of Qorvo’s extensive portfolio of RF BAW and SAW filters.



3 Pin 2 x 1.6 mm leadless SMT Package

Functional Block Diagram

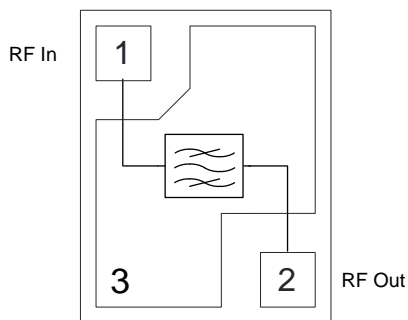

Top View

Pin Configuration

Pin No.	Label
1	RF In
2	RF Out
3	GND Back Side Paddle

Product Features

- 194 MHz Bandwidth – Band 41
- High Attenuation
- Low Loss
- No External Matching Required
- Excellent Wi-Fi Rejection
- Single Input, Single Output Operation
- Small Size: 2.00 x 1.60 x 0.73 mm
- Surface Mount Device
- RoHS Compliant, Pb-Free

Performance is typical across frequency. Please reference electrical specification table and data plots for more details.

Applications

- Band 41
- Base Station Infrastructure
- Small Cells
- Repeaters
- Routers
- LTE Dongles
- General Purpose Wireless

Ordering Information

Part No.	Description
QPQ1285SR	100 pieces on a 7" reel
QPQ1285TR7	2,500 pieces on a 7" reel (standard)
QPQ1285EVB	Evaluation Board

Absolute Maximum Ratings

Parameter	Rating
Storage Temperature	-40 to +125 °C
Operation Temperature	-40 to +95 °C

Exceeding any one or a combination of the Absolute Maximum Rating conditions may cause permanent damage to the device. Extended application of Absolute Maximum Rating conditions to the device may reduce device reliability.

Life Test

Conditions	Rating
+30.5 dBm, +95 °C, FD-LTE, 5MHz 16QAM, 5MHz, PAR=8.5dB	>124,000 Hrs.
+29 dBm, +85 °C, FD-LTE, 5MHz 16QAM, 5MHz, PAR=8.5dB	>294,000 Hrs.
+24 dBm, +95 °C, FD-LTE, 5MHz 16QAM, 5MHz, PAR=8.5dB	>15M Hrs.

Power is applied to Pin 1.

Electrical Specifications

Parameter	Conditions	Min	Typ	Max	Unit
Frequency Range		2496		2690	MHz
Insertion Loss		-	3.5	4.3	dB
Amplitude Variation ⁽³⁾		-	1.1	2.1	dB
	Any 5 MHz Window	-	0.4	1.2	dB
Input / Output Return Loss		10	13	-	dB
Integrated Rejection (over 20 MHz Bandwidth)	2402 - 2422 MHz	40	53	-	dB
	2407 - 2427 MHz	45	57	-	dB
	2412 - 2432 MHz	50	60	-	dB
	2417 - 2437 MHz	50	61	-	dB
	2422 - 2442 MHz	50	60	-	dB
	2427 - 2447 MHz	50	60	-	dB
	2432 - 2452 MHz	50	60	-	dB
	2437 - 2457 MHz	50	60	-	dB
	2442 - 2462 MHz	50	59	-	dB
	2447 - 2467 MHz	50	57	-	dB
	2452 - 2472 MHz	50	55	-	dB
2412 - 2467 MHz	50	57	-	dB	
Attenuation ⁽⁴⁾	10 - 700 MHz	41	48	-	dB
	701 - 900 MHz	28	34	-	dB
	901 - 1564 MHz	22	28	-	dB
	1565 - 1615 MHz (GPS)	33	41	-	dB
	1616 - 1709 MHz	31	40	-	dB
	1710 - 1880 MHz (B3)	26	32	-	dB
	1920 - 2170 MHz (B1)	15	18	-	dB
	2300 - 2330 MHz	17	21	-	dB
	2472 - 2477 MHz (WiFi Ch12)		36	-	dB
	3000 - 3900 MHz	27	30	-	dB
	3900 - 4100 MHz	15	18	-	dB
	4100 - 6000 MHz	34	27	-	dB
	6000 - 7500 MHz	29	36	-	dB
	7500 - 8000 MHz	25	33	-	dB
Harmonics	H2: 2496-2690 MHz, 5 MHz Step, 28 dBm	60	70	-	dBc
	H3: 2496-2690 MHz, 5 MHz Step, 28 dBm	100	110	-	dBc

Notes:

1. Test conditions unless otherwise noted: Temp = -40 °C to +95 °C
2. All specifications are based on the QORVO schematic for the main reference design shown on page 3.
3. This is defined as the worst difference between a peak and adjacent valley within defined frequency points
4. Attenuation is referenced to ZERO dB

Evaluation Board and Schematic

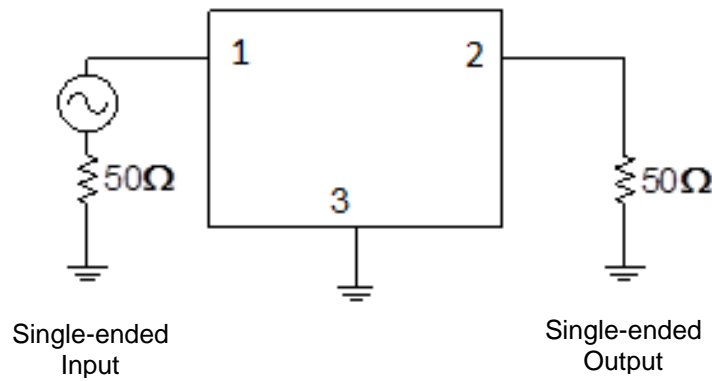
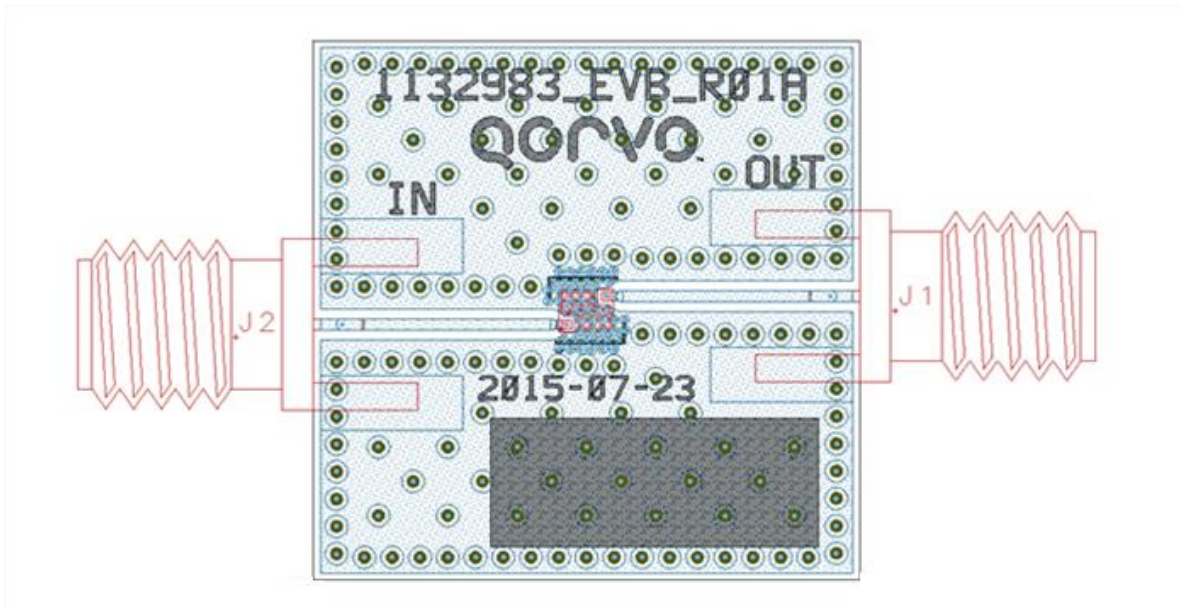

Bill of Material

Reference	Value	Description	Manufacturer	Part Number
U1	N/A	Band 41 BAW Filter	Qorvo	QPQ1285
PCB	N/A	Printed Circuit Board	Various	
SMA	N/A	SMA Edge Connector	Various	

Performance Plots – Application Circuit

Test conditions unless otherwise noted: Temp.= +25 °C

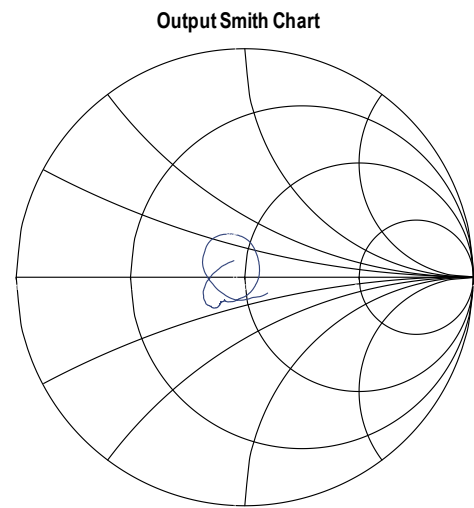
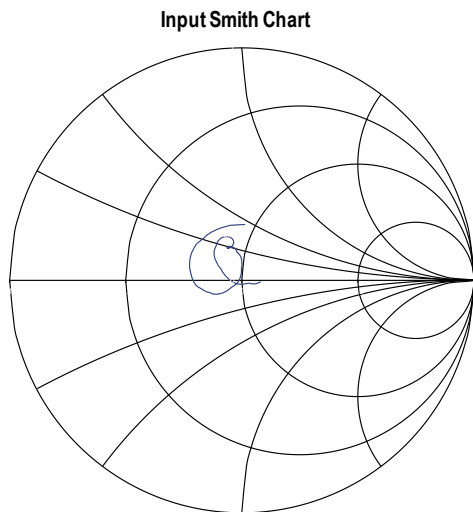
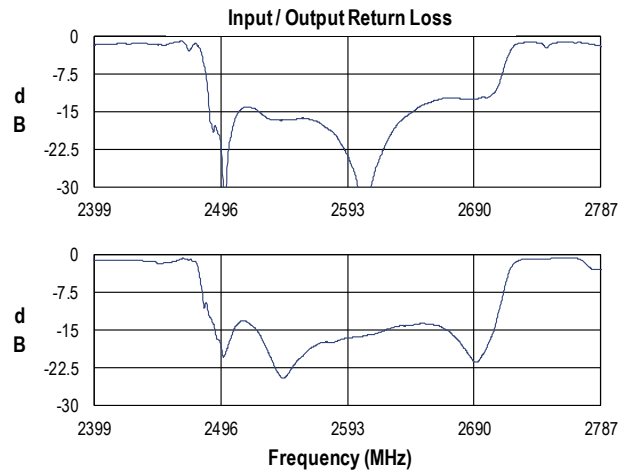
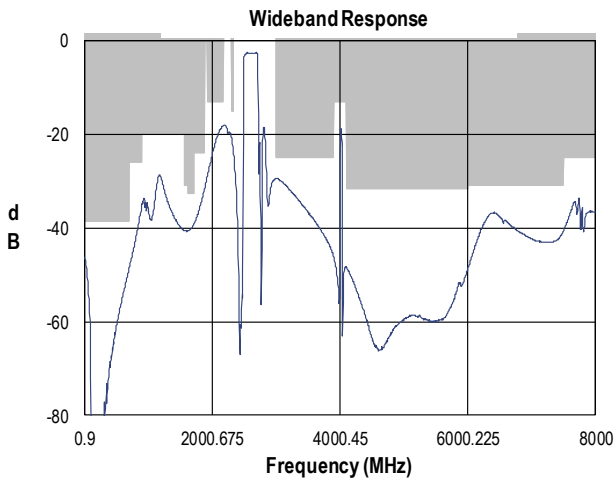
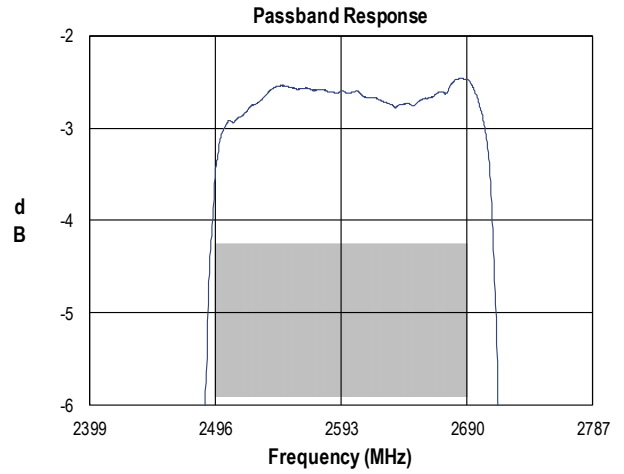
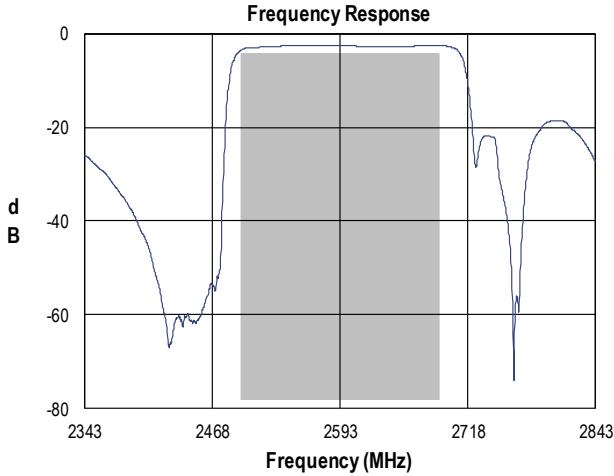

Package Marking and Dimensions

Marking

4-digit Part number: 1285
 4-digit Trace code: XXXX

Body: Al₂O₃ ceramic

Lid: Kovar, Au over Ni plating

Terminations: Au plating 0.5 - 1.0µm, over a 2-6µm Ni plating

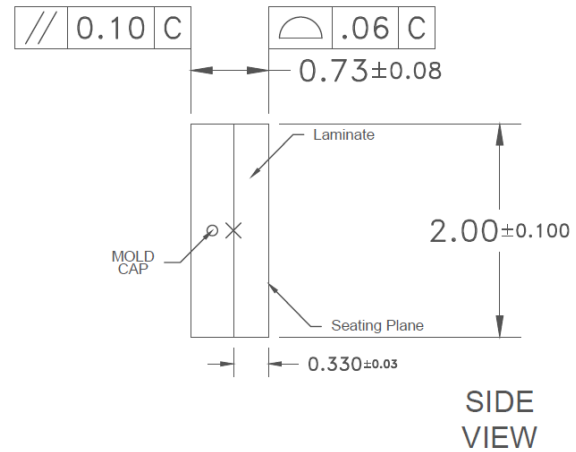
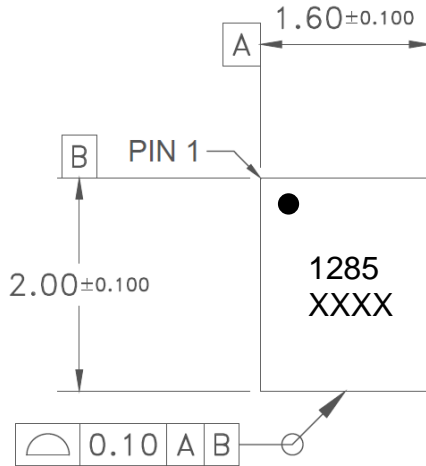

TOP VIEW

SIDE VIEW

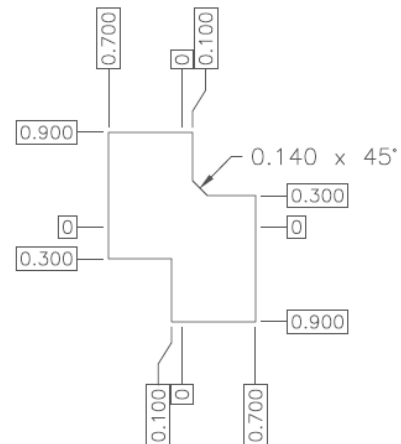
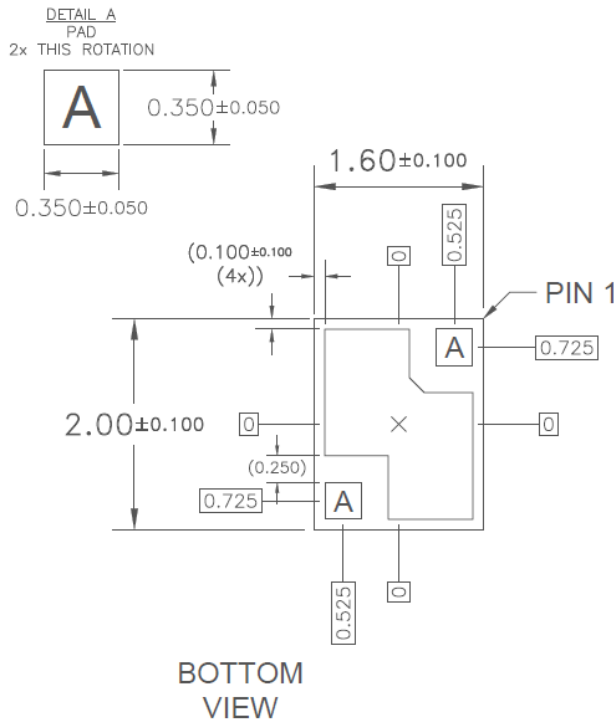

Notes:

1. All dimensions are in millimeters. Angles are in degrees.
2. Dimension and tolerance formats conform to ASME Y14.4M-1994.
3. The terminal #1 identifier and terminal numbering conform to JESD 95-1 SPP-012.

PCB Mounting Pattern

All dimensions are in millimeters

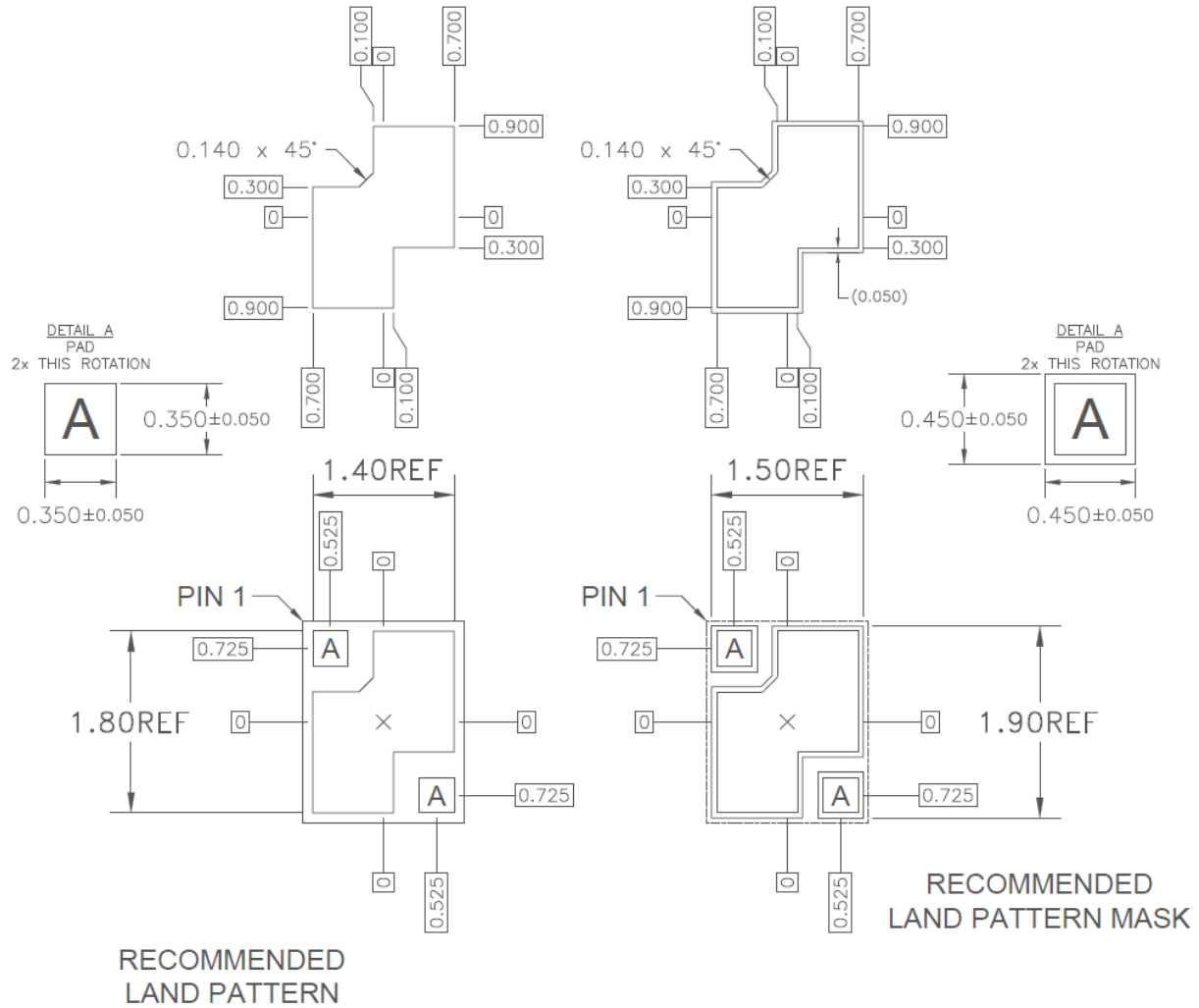

Tape and Reel Information – Carrier and Cover Tape Dimensions

Tape and reel specifications for this part are also available on the Qorvo website.
 Standard T/R size = 2500 pieces on a 7" reel.

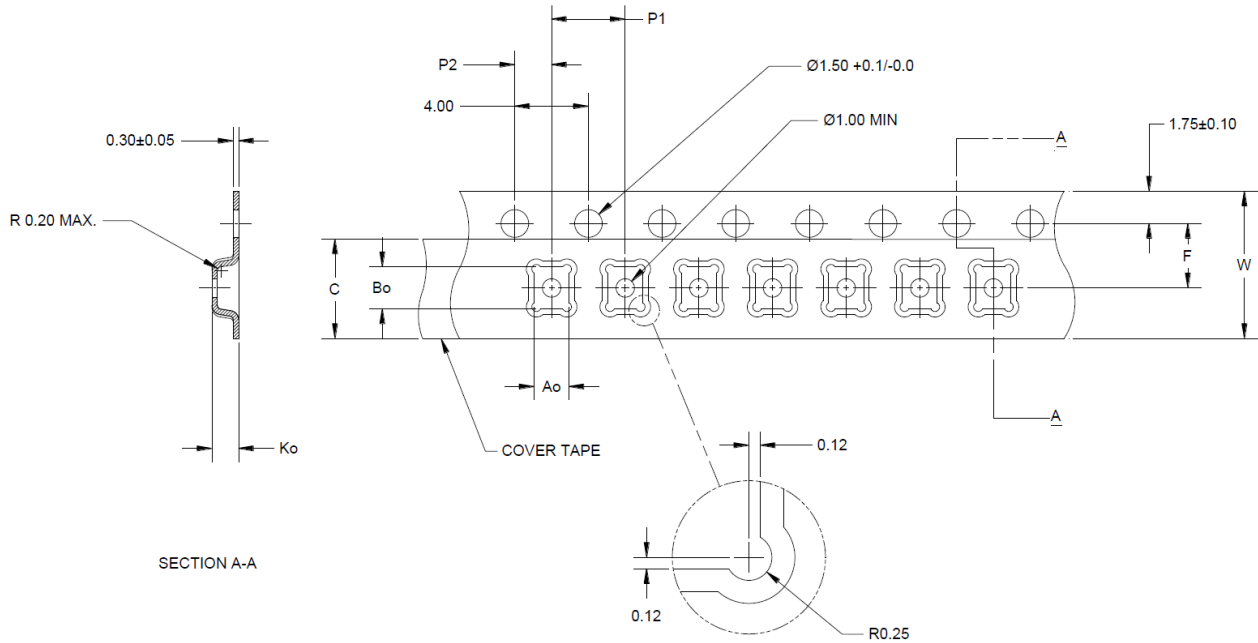

Feature	Measure	Symbol	Size (in)	Size (mm)
Cavity	Length	A0	0.077	1.95
	Width	B0	0.093	2.35
	Depth	K0	0.045	1.15
	Pitch	P1	0.157	4.00
Centerline Distance	Cavity to Perforation - Length Direction	P2	0.079	2.00
	Cavity to Perforation - Width Direction	F	0.138	3.50
Cover Tape	Width	C	0.213	5.40
Carrier Tape	Width	W	0.315	8.00

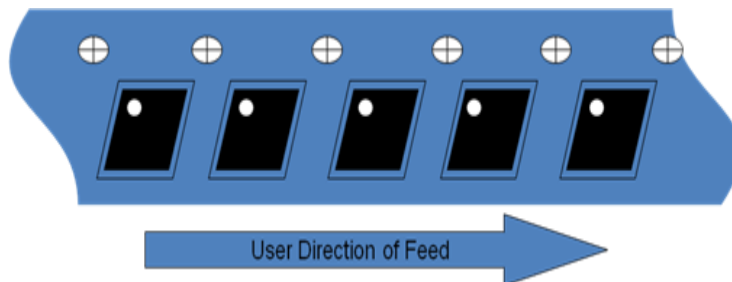

Tape and Reel Information – Reel Dimensions

Tape and reel specifications for this part are also available on the Qorvo website.
 Standard T/R size = 2500 pieces on a 7" reel.

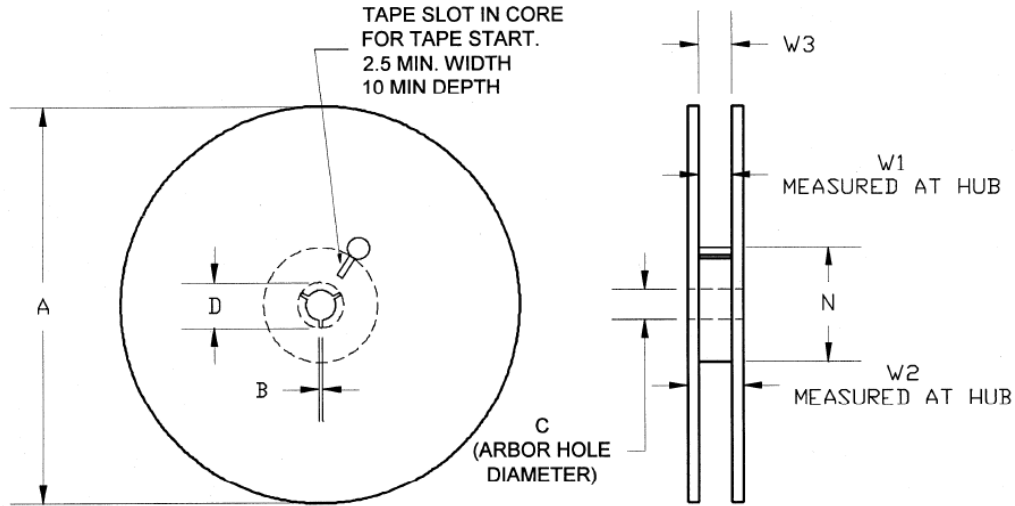

Feature	Measure	Symbol	Size (in)	Size (mm)
Flange	Diameter	A	6.969	177.0
	Thickness	W2	0.559	14.2
	Space Between Flange	W1	0.346	8.8
Hub	Outer Diameter	N	2.283	58.0
	Arbor Hole Diameter	C	0.512	13.0
	Key Slit Width	B	0.079	2.0
	Key Slit Diameter	D	0.787	20.0