

TREK-570

Compact In-Vehicle Computing Box for Fleet Management



Features

- Equipped with DeviceOn/iService software for remote device management
- Can be paired with TREK-303/306 in-vehicle smart display via a single-cable connection
- Supports real-time rear view monitoring
- Dual independent displays/audio outputs for in-vehicle infotainment and digital signage applications
- Vehicle diagnostics interface with support for configurable CAN (J1939, OBD-II/ISO 15765) and J1708 (J1587) protocols
- Built-in GNSS, WLAN, Bluetooth, and WWAN (with a dual SIM card slot) modules
- Wide operating temperature range (-30 ~ 70 °C/-22 ~ 158 °F)
- MIL-STD-810G and 5M3 certified for shock and vibration tolerance

DeviceOn/iService

Introduction

TREK-570 is a compact and economical in-vehicle computing box powered by an Intel® Atom™ E3826 SOC and can be paired with TREK-303/306 in-vehicle smart displays via a single-cable connection. Aimed at fleet management applications, TREK-570's wide operating temperature and MIL-STD-810G and 5M3 certification for shock vibration resistance enable it to withstand harsh environments. The inclusion of an intelligent vehicle power management (VPM 2.0) chip protects against transient voltage (ISO 7637-2/SAE J1455/SAE J1113) and enables programmable functions (ignition on/off, delay on/off, and low battery monitoring). TREK-570 also features various I/O for integrating CAN bus devices and peripherals, such as a tire pressure monitoring system. The dual CAN bus ports support diverse protocols (J1939, OBD-II/ISO 15765) to facilitate vehicle diagnostics and driver behavior management. Built-in wireless communication technologies (WLAN, WWAN, Bluetooth) enable vehicle tracking and real-time data transmissions to a centralized control center. TREK-570 also supports dual independent displays/audio outputs for in-vehicle infotainment and digital signage applications.

Moreover, TREK-570 is equipped with Advantech's DeviceOn/iService software, which is a next-generation unified device management solution based on the WISE-DeviceOn platform. With support for batch operations and multi-device control, DeviceOn/iService enables easy device configuration and deployment for convenient remote device management.

Specifications

Core	Processor	Intel® Atom™ E3826, dual-core, 1.46 GHz	
	Memory	1 x 2 GB DDR3L SODIMM 1066 MHz, non-ECC (up to 4 GB)	
	Graphics	Integrated 2D/3D graphics engine	
	Operating System	WES7, WES8, Win10 IoT LTSC (32 bit), Linux Ubuntu 14.04 Kernel 3.19.0 (32 bit)	
Storage	mSATA	1 x 16 GB UMLC, SQFlash mSATA, with support system bootup	
Display	Smart Display Ports ¹	1 x 12V/2A power output for TREK-30x	
		1 x 18-bit LVDS with 800 x 480/1024 x 768 resolution and automatic detection	
		1 x Line-Out2 (for TREK-30x speakers)	
2 x UART (TX/RX, TX/RX/RTS) (for touchscreen, hot keys, and brightness/light sensor control)			
		1 x USB 2.0 Type A	
		1 x Power button	
		1 x Reset button	
	VGA	1 x DB15 (up to 2560 x 1600 resolution)	
	HDMI ³	1 x HDMI (up to 2560 x 1600 resolution)	
I/O	Vehicle I/O	2 x CAN bus with raw CAN, J1939, and OBD-II/ISO 15765 support (configurable via firmware)	
		1 x J1708 with J1587 support	
		1 x 4-wire RS-485 with auto flow control	
	Generic I/O	2 x 4-wire RS-232	
		4 x Isolated DI (dry contact)	
		4 x Isolated DO (open collector output, driven by relay)	
		1 x CVBS-In (for real-time rear view monitoring)	
			1 x Line-Out ²
			1 x Mic-In
	Standard I/O		1 x USB 3.0 Type A (rear side, with cable clip)
		1 x USB 2.0 Type A (rear side, with cable clip)	
		1 x High-speed full RS-232, DB-9 (Pin 9 = ring, 12/5 V @0.5 A in BOM; optional via jumper setting)	
		1 x Giga LAN, with locking RJ45 connector	
	LED Indicators	5 x LEDs: 1 x Power (red), 1 x Storage (yellow), 1 x WLAN (green), 1 x WWAN (green), 1 x GPS (yellow)	
	Power Button	Via TREK-30x in-vehicle smart display; system is powered on by vehicle ignition as a default	
	Reset Button	1 x Reset button (rear side)	
RF	WLAN + Bluetooth	IEEE 802.11a/b/g/n + Bluetooth V4.0 combo module via full mini PCIe slot (optional high-power WLAN/WLAN roaming available upon request)	
	WWAN	4G (LTE, HSPA+, GSM/GPRS/EDGE, EV-DO Rev. a1, 1xRTT) Sierra Wireless MC73xx via full mini PCIe slot (default: MC7354 for US/MC7304 for EU)	
	GNSS	MAC-M8Q/W GPS/GLONASS/BeiDou 3 in 1 module	
	Antenna	5 x SMA-type antenna holes for GPS, Wi-Fi+Bluetooth MIMO, WWAN/LTE MIMO ⁴	

Specifications Cont.

Power	Input Voltage	Compatible with 12/24 V vehicle power (6 ~ 32 VDC input; ISO 7637-2 and SAE J1113 compliant) System power on/off/hibernate management (programmable ignition on/off delay)
	Intelligent Vehicle Power Management (iVPM 2.0)	Supports wake-up events: Wake on Alarm (RTC), Wake by Call/SMS, Wake by G-sensor, and Wake by DI (DI0 & DI1) System power protection (low voltage protection for vehicle battery) System monitoring and diagnostics
Mechanical	Dimensions (W x H x D)	Standalone unit: 230 x 72 x 118 mm (9.05 x 2.83 x 4.64 in) With IP54-rated I/O cover: 230 x 72 x 198 mm (9.05 x 2.83 x 7.79 in)
	Weight	Standalone unit: 1.45 kg (3.19 lb) With IP54-rated I/O cover: 1.95 kg (4.29 lb)
Environment	IP Rating	IP30 (optional IP54-rated I/O cover available upon request)
	Vibration/Shock	MIL-STD-810G, EN60721-3(5M3)
	EMC	CE, FCC, CCC
	Safety	UL/cUL, CB
	Vehicle Regulations	E-Mark (E13), SAE J1455 class C, ISO 7637-2, SAE J1113
	RF Regulations	CE (R&TTE), FCC ID, PTCRB
	Operating Temperature	-30 ~ 70 °C (-22 ~ 158 °F)
Storage Temperature	-40° C ~ 80° C (-40 ~ 176 °F)	
DeviceOn/iService Remote Device Management	Operating System	Windows 10
	Common Controls (Reboot, Shutdown)	✓
	Remote desktop	✓ (VNC)
	Device-Specific Controls (Audio, Backlight)	✓*
	Connection Status	✓
	Hardware Status	✓*
	Hard Disk Status	✓*
	Batch Operation Support	✓
	OTA Storage Management	FTP
	OTA Software Updates	✓
	Software Watchlist	✓
	Software Start/Stop	✓*
	Peripherals Watchlist	✓*

*Dependant on device model

¹ When paired with TREK-303/306 via a single-cable connection

² Supports dual independent audio streams. The Line-Out interfaces of the smart display ports and generic I/O are driven by different audio codecs.

³ BYT-I can support dual independent displays (smart display + VGA, smart display + HDMI, or VGA + HDMI).

⁴ The box-side connector is RP-SMA, female (external female thread with male internal pin)

Note: DeviceOn/iService software must be downloaded from the Advantech website at <https://www.advantech.com/search/?q=DeviceOn%2FiService&st=support&sst=Utility>

Dimensions

Unit: mm

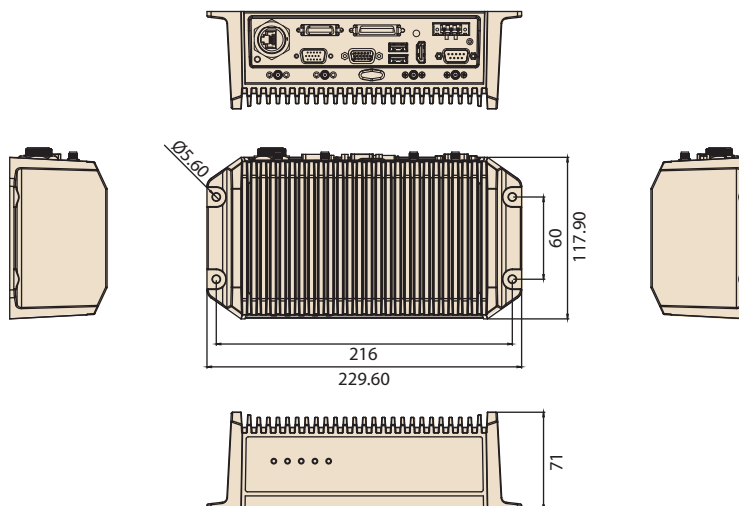

System I/O

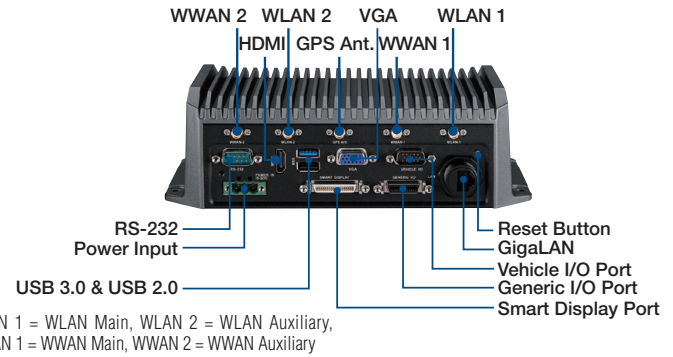

Ordering Information

Part Number	Description
TREK-570-00A0E	TREK-570 Intel BYT E3826, dual-core, 1.46 GHz, barebone unit
TREK-570-HWB7A0E	TREK-570 w/LTE (EU)/GPS/WLAN/BT/WES7
TREK-570-LWB7B0E	TREK-570 w/LTE (US)/GPS/WLAN/BT/WES7
TREK-570-LWBXA0E	TREK570 w/LTE(EU)/GPS/WLAN/BT/W10 IoT LTSB
TREK-570-LWBXB0E	TREK570 w/LTE(US)/GPS/WLAN/BT/W10 IoT LTSB

Note: WES8, and Linux OS images are available upon request.

Optional Accessories

Part Number	Description
TREK-303R-HA0E	TREK-303 7" WVGA in-vehicle smart display
TREK-306D-HA0E	TREK-306DH 10.4" XVGA in-vehicle smart display
1700020007	M cable SCSI-36P(M)/SCSI-36P(M), 2 m, for TREK-303
1700020008	M cable SCSI-36P(M)/SCSI-36P(M), 5 m, for TREK-303
1700019464	A cable 1*3P-5.08/DC jack+SW, 155 mm, for in-house testing
96PSA-A65W19V1-1	Adaptor 100-240 VAC, 60W, 12 V, 5A, w/o PFC FSP060-DBA, for in-house testing

Packing List

Part Number	Description
1700019031	Power cable, 2 m
1700023050-11	Generic I/O cable
1700023051-01	Vehicle I/O cable
1654011716-01	Waterproof RJ45 locking kit
1750007724-01	3-in-1 (LTE/GPS/Wi-Fi) antenna, 3 m
1750007723-01	Wi-Fi antenna, 3 m