

TS1108 Coulomb Counter User's Guide

The TS1108 coulomb counter accurately measures battery depletion while also indicating the battery charging polarity. The battery discharge current is monitored by a current-sense amplifier through an external sense resistor. Utilizing an Integrator and a Comparator plus a Monoshot, the TS1108 voltage-to-frequency converter provides a series of 90 μ s output pulses at COUT, which represents an accumulation of coulombs flowing out of the battery. The charge count frequency is adjustable by the integration resistor and capacitor.

The TS1108 CSA requires a very low 1.2 μ A supply current, while also combining a 150 μ V VOS(MAX) with a 0.6% gain error (MAX) for high precision current measurements. The TS1108 provides a buffered CSA output which can be connected with a RC Filter to reduce noise. The VDD supply requires a typical supply current of 1.93 μ A when VREF is disabled.

The TS1108 is fully specified to operate over the -40°C to $+85^{\circ}\text{C}$ temperature range and is available in a low-profile thermally-enhanced 16-pin 3 x 3 mm TQFN package with an exposed back-side paddle.

KEY FEATURES

- R_{SENSE} : 50 m Ω \pm 0.5%
- Compatible for Both Gain Options
 - 20 V/V
 - 200 V/V

ORDERING INFORMATION

- TS1108-20DB
- TS1108-200DB

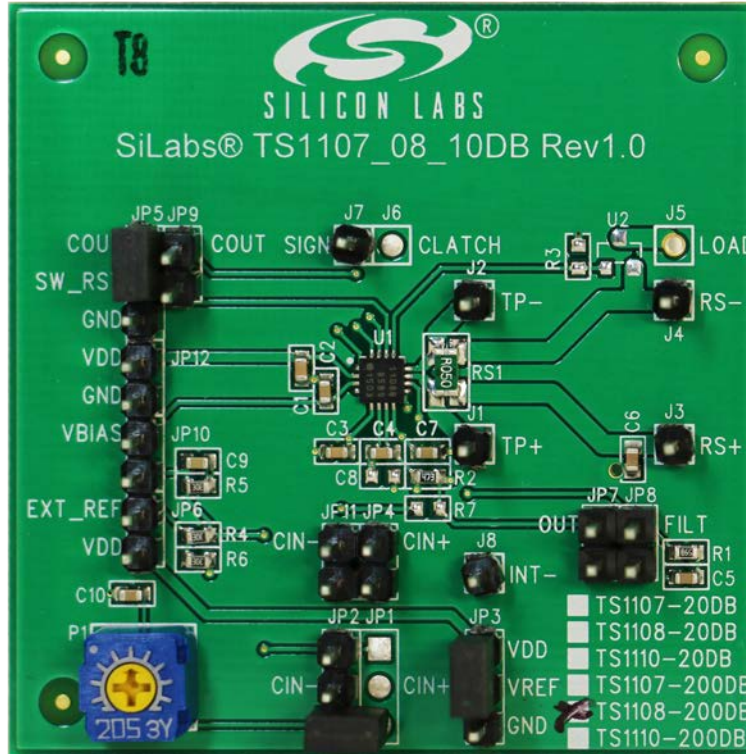

1. Description

The TS1108 Evaluation Board is intended for evaluating the coulomb counter functionality of the TS1108. The TS1108 Coulomb Counter function utilizes an Integrator and a Comparator plus a 90 μs Monoshot. The CSA's buffered output is applied to the integrator's input. This signal is integrated by the comparator until it reaches a level which trips the comparator. The comparator's trip level is determined by the voltage applied to the comparator's non-inverting terminal, CIN+. The Monoshot produces a 90 μs output pulse at COUT and the integrator is reset. Therefore, each COUT 90 μs pulse represents an accumulation of coulombs (Please refer to Coulomb Counter Equations in Applications Information). The TS1108 Integrator works best when the 90 μs Monoshot represents less than 2% of the total integration period. Therefore, the minimum integration time for a full-scale V_{SENSE} should be limited to 4.7 ms. To guarantee stable operation of the OUT buffer, an integration capacitance of 0.1 μF should be used for integration capacitor, C_{INT}. The TS1108's Coulomb Counting interrupt is provided by the internal comparator with a push-pull output configuration.

The following equation can be used to calculate how many ampere-hours (Ah) each comparator interrupt pulse represents:

$$\text{ComparatorPulse} = \frac{R_{INT} C_{INT} (V_{CIN-} - V_{VBIAS})}{3600 \times GAIN \times R_{SENSE}} \text{Ah}$$

Table 1.1. Component List

Designation	Quantity	Description
U1	1	TS1108-20, TS1108-200
RS1	1	50 mΩ ±0.5%, 1/2 W (1206)
C1, C6	2	1 μF ± 10%, 10 V (0603)
C2, C4, C7, C9, C10	5	0.1 μF ± 10%, 10 V (0603)
C3	1	1 nF ± 10%, 25 V (0603)
C5	1	0.47 μF ± 10%, 10 V (0603)
R1	1	4.02 kΩ ± 1%, 1/16 W (0603)
R2	1	47 kΩ ± 1%, 1/16 W (0603)
R4, R5, R6	3	2 MΩ ±1%, 1/10 W (0603)
J1, J2, J3, J4, J7, J8	6	Header 1x1
JP2, JP3, JP5	3	Header 1x3
JP4, JP6, JP7, JP8, JP9, JP10, JP11, JP12	8	Jumper
JS1, JS2, JS3	3	Jumper Shunt

2. Quick Start Procedure

Required Equipment

- 3 V Power Supply or 3 V Battery
- 2 Digital Multimeters
- 1 Oscilloscope
- 1 Potentiometer

To use the TS1108 evaluation board, perform the following steps:

1. Configure JP3 so that the Jumper Shunt is connecting VDD to VREF.
2. Configure JP5 so that the jumper shunt is connecting COUT and SW_RST.
3. Connect the 3 V power source to RS+ and VDD.
4. Use a voltmeter to measure the V_{BIAS} and the $CIN-$ voltage. V_{BIAS} should be 50% of VDD, 1.5 V. $CIN-$ should be 90% of VDD, 2.7 V.
5. Connect a voltmeter to measure V_{OUT} . With no load connected V_{OUT} should be equal to V_{BIAS} . The expression for the V_{OUT} output voltage is defined by:

$$V_{OUT} = V_{BIAS} - I_{LOAD} \times 50m\Omega \times GAIN$$

6. Connect an ammeter in series from RS- to a potentiometer. Adjust the POT until the ammeter reads:
 - TS1108-20: 500 mA
 - TS1108-200: 50 mA

V_{OUT} should equal 1 V.

7. Connect the oscilloscope to COUT. COUT should produce a periodic pulsing waveform with a period of 11.28 ms, where each monoshot pulse width is 90 μ s (typ).

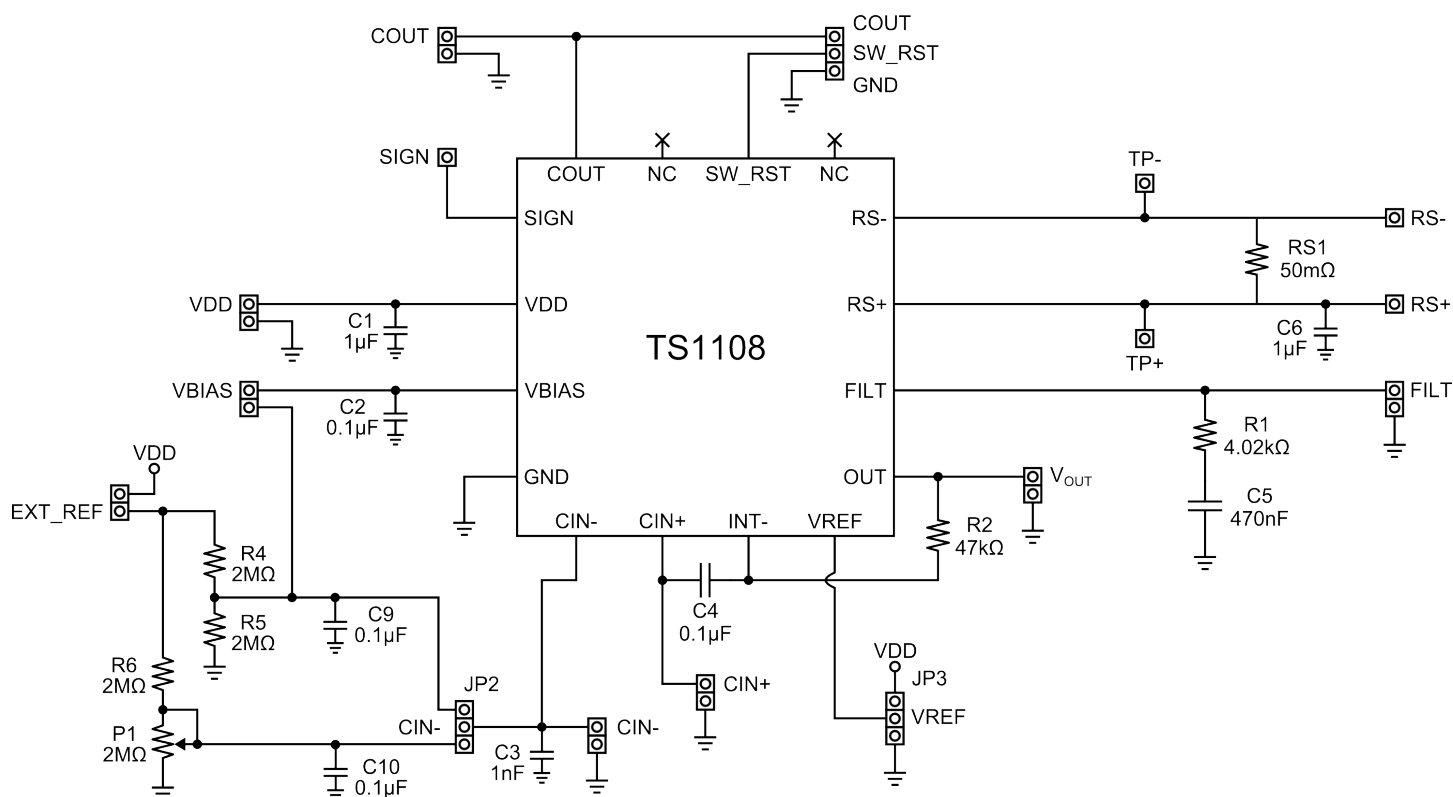

Figure 2.1. TS1108DB Circuit Schematic